

IMACS Integrated Access Device User Guide

August 2014
Document Part Number: 830-03910-03 version A2

Release 7.2.3

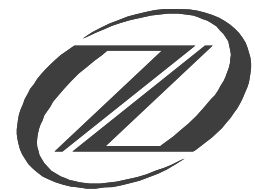

Z H O N E™

Zhone Technologies
@Zhone Way
7195 Oakport Street
Oakland, CA 94621
USA
510.777.7000
www.zhone.com
info@zhone.com

COPYRIGHT ©2000-2014 Zhone Technologies, Inc. and its licensors. All rights reserved.

This publication is protected by copyright law. No part of this publication may be copied or distributed, transmitted, transcribed, stored in a retrieval system, or translated into any human or computer language in any form or by any means, electronic, mechanical, magnetic, manual or otherwise, or disclosed to third parties without the express written permission from Zhone Technologies, Inc.

Acculink, ADSL/R, Bitstorm, Comsphere, DSL the Easy Way, Etherloop, EtherXtend, FrameSaver, GrandSLAM, GrandVIEW, Hotwire, the Hotwire logo, IMACS, JetCraft, Jetstream, JetVision, MALC, MXK, Net to Net Technologies, Paradyne, the Paradyne logo, Raptor, ReachDSL, SLMS, StormPort, Z-Edge, Zhone, the Zhone logo, ZMS, and zNID are trademarks owned by Zhone Technologies, Inc., which may be registered in some jurisdictions.

Zhone Technologies makes no representation or warranties with respect to the contents hereof and specifically disclaims any implied warranties of merchantability, non infringement, or fitness for a particular purpose. Further, Zhone Technologies reserves the right to revise this publication and to make changes from time to time in the contents hereof without obligation of Zhone Technologies to notify any person of such revision or changes.

Table of Contents

Volume 1 System Reference Guide

Chapter 1 What's New

1.1	Product Description	1-1
1.1.1	CPU Card Support.....	1-1
1.1.2	Interface Cards Supported in Release.....	1-2
1.1.3	Low interruption Cards Supported in Release 7.x.y.....	1-2
1.2	System Cards	1-2
1.2.1	Card Support.....	1-2
1.2.1.1	CPU XCON (880770)	1-2
1.2.1.2	Voice Cards	1-3
1.2.1.3	Data Cards	1-3
1.2.1.4	Server Cards	1-4
1.2.1.5	Alarm Cards	1-4
1.3	Customer Service and Ordering Information	1-5
1.3.1	Technical support	1-5

Chapter 2 System Installation

2.1	Introduction	2-1
2.2	User-Set Switches and Jumpers	2-1
2.3	Chassis Installation	2-1
2.3.1	Unpacking the Chassis and Cards	2-1
2.3.2	Pre-Installation Tips	2-2
2.3.2.1	Installation Checklist.....	2-2
2.3.3	Choosing a Location for Your System	2-3
2.3.3.1	Rack Installation Tips.....	2-3
2.3.3.2	Wall-Mount Installation Tips	2-4
2.3.3.3	Tabletop Installation Tips.....	2-4
2.3.4	Installing the Chassis	2-4
2.3.4.1	Front-Loading Chassis with Power Supplies on Side	2-4
2.3.4.2	Front-Loading Chassis with Power Supplies on Top.....	2-6
2.3.4.3	Two-Sided Chassis	2-7
2.4	Power Supplies and Ringing Generators	2-8
2.4.1	System Power (Redundancy)	2-8
2.4.2	-48V Talk Battery Requirements.....	2-8
2.4.3	Setting the U.S./European Configuration Jumper	2-8
2.4.4	Installing the System Power Cards.....	2-9
2.4.5	Talk Battery Supply Fuses.....	2-9

Table of Contents

2.4.6	AC Power Supply and DC Power Supply Fuses	2-9
2.4.7	Installing AC or DC Power Supplies	2-10
2.4.8	Installing the -48V Converters (8903/8905/8908).....	2-10
2.5	Ringing Generators	2-11
2.5.1	Ringing Generators (8906/890620)	2-12
2.5.2	Installing the 105V Ringing Generator (8906/890620).....	2-12
2.6	System Power and Ground Connections	2-14
2.6.1	Front-Loading Chassis with Power Supplies on the Side (891630)	2-14
2.6.2	Two-Sided Chassis (891830).....	2-17
2.6.3	Power Enhanced Chassis with Power Supplies in Front (891930).....	2-20
2.7	Special Grounding Considerations	2-23
2.7.1	For -48VDC Powered Systems.....	2-24
2.7.2	For 120/240 AC Powered Systems.....	2-26
2.7.2.1	Front-Loading Chassis: Power Supplies on Side	2-26
2.7.2.2	Two-Sided Chassis	2-27
2.7.2.3	Front-Loading Chassis: Power Supplies on Top	2-27
2.8	Special Grounding Considerations	2-30
2.8.1	External Ringing Generators and other special circumstances.....	2-30
2.8.1.1	Two-Sided or Front-Loading Supplies on Side.....	2-30
2.8.1.2	Front-Loading Chassis Supplies on Top	2-31
2.9	Powering Up the System	2-32
2.10	Installing the Other Plug-In Cards	2-32
2.10.1	Interface Cards (893270 / 893370 / 893470).....	2-32
2.10.2	CPU Card (880770).....	2-32
2.10.3	WAN Cards (801060 / 801065 / 801070 / 801470).....	2-33
2.10.4	Server Cards.....	2-33
2.10.5	User Cards.....	2-33
2.10.6	Connecting Cables to the Cards.....	2-34

Chapter 3 Chassis Descriptions

3.1	Introduction	3-1
3.2	Chassis Types	3-2
3.2.1	Front-Loading Chassis with Power Supplies on the Side (891630)	3-2
3.2.2	Two-Sided 891830 Chassis	3-4
3.2.3	Front-Loading 891930 Chassis with Enhanced Power Supply	3-7
3.3	U.S. and European Chassis Configuration	3-11

Chapter 4 Applications

4.1	Introduction	4-1
4.2	Voice Modules	4-1
4.2.1	Foreign Exchange Station (FXS) Card (812960)	4-1
4.2.2	Foreign Exchange Office (FXO) Card (813970).....	4-2
4.2.3	E&M Card (811960).....	4-4
4.2.4	Voice Channel Bank Application	4-4
4.2.5	TR008 Application	4-6

4.2.6	T1-E1 Conversion Application.....	4-7
4.3	Data Modules and Applications	4-8
4.3.1	HSU Card (820260 820360 821260 821460 821570 & 821660).....	4-8
4.3.2	HSU Application Example	4-10
4.3.3	OHSU Card (823760).....	4-10
4.3.4	SRU Card (822060).....	4-11
4.3.5	OCU-DP Card (8249, 824660 & 824760).....	4-13
4.3.5.1	OCU-DP Card Models	4-13
4.3.6	DSO-DP Card (825460)	4-15
4.4	ADPCM Voice Compression Server (887170)	4-15
4.4.1	PBX to PBX Trunk Application.....	4-17
4.5	Management Channel Concentrator (MCC) Server (881360)	4-18
4.6	Routing Server	4-20
4.6.1	Bundled Service Deployment.....	4-22
4.6.2	Private Intranet Deployment.....	4-23
4.6.3	IP Routing Server Specifications.....	4-24

Chapter 5 System Configuration and Operation

5.1	Basic Operations	5-1
5.2	Basic Screen Map and Legend	5-2
5.3	System Initialization	5-2
5.3.1	Registration.....	5-3
5.3.2	Logging Into the System	5-8
5.3.3	User Names, Passwords and Groups	5-10
5.3.3.1	User Groups.....	5-12
5.3.4	Access Level Permissions	5-18
5.4System Screens	5-20
5.4.1	System Main Screen	5-20
5.4.2	CPU Card Status.....	5-20
5.4.3	Power Supplies and Ringing Generators Card Status	5-21
5.4.4	Voice and Data Card Status.....	5-21
5.4.5	Server Card Status	5-22
5.4.5.1	MCC Card	5-22
5.4.5.2	WAN Card.....	5-22
5.4.6	Card Main Screens	5-22
5.4.7	Test and Debug Screen	5-25
5.4.8	Time Slot Configuration and Cross-Connect Screens	5-25
5.5	Card Configuration	5-25
5.5.1	Selecting and Configuring Your Cards	5-25
5.5.2	Recording Your Configuration Settings	5-26
5.6	Reinitializing the System	5-27
5.7	Alarms	5-29
5.7.1	Alarm Screens	5-29
5.7.2	Alarm Filter Settings	5-31
5.7.3	Alarm Modifiers	5-34
5.7.4	Alarm Cutoff (ACO)	5-34

Table of Contents

5.7.5	Backplane Out of Service (BP_OOS).....	5-34
5.7.6	Alarm Handling	5-35
5.8	Time Slot Configuration Screen	5-37
5.9	Deleting an Out of Service Card	5-37
5.10	Accepting New Card Settings	5-37
5.11	Cross-Connecting (XCON)	5-37
5.11.1	Alternative Mapping Table.....	5-38
5.11.1.1	Remote AMT.....	5-39
5.11.1.2	Active AMT.....	5-42
5.11.1.3	ALARM FILTER TRIGGERS.....	5-44
5.11.1.4	ALARM INFORMATION.....	5-45
5.11.1.5	QUICK TIPS:	5-45
5.12	System Level Maintenance	5-46
5.12.1	Test, Debug, Backup & Restore	5-46
5.12.2	Zipping the System	5-46
5.12.3	Debugging the System	5-47
5.12.4	Registering the System	5-47
5.12.5	Pre-TFTP Backup and Restore Preparation.....	5-48
5.12.6	TFTP Backup for 7.x.y	5-49
5.12.7	TFTP Restore for 7.x.y	5-50
5.12.8	ASCII Backup Procedure.....	5-51
5.12.9	ASCII Restore Procedure.....	5-52
5.12.10	XMODEM 128k and XMODEM 1k Backup.....	5-52
5.12.11	XMODEM 128k and XMODEM 1k Restore.....	5-53
5.13	Taking a Card Out of Service	5-54
5.14	CPU Switching	5-54
5.15	Time Slot Assignment	5-54
5.15.1	Modes of Operation	5-55
5.15.1.1	XCON Mode (XCON).....	5-55
5.16	Assigning Time Slots	5-55
5.16.1	Assigning a Time Slot to a User Card Port.....	5-55
5.16.2	Assigning Multiple Time Slots to a Port	5-57
5.16.3	Cross-Connect Model	5-60
5.17	Circuit Names	5-60
5.17.1	Display and Change Circuit Names.....	5-61
5.17.2	Backup and Restore Circuit Name Table	5-65
5.17.3	SNMP.....	5-66
5.18	DS0 Naming	5-66
5.19	Automatic Time Slot Assignment	5-68
5.20	Cross-Connecting WAN Time Slots	5-73
5.21	Cross-Connect Actions	5-89
5.22	Testing Voice Cross-Connects	5-92
5.23	Using the Broadcast Option	5-96
5.23.1	WAN Link to WAN Link	5-103
5.23.2	Broadcast Screen Actions	5-103
5.23.3	Test Access Digroups (TADS)	5-104
5.23.4	Monitor Circuit	5-105
5.23.5	Split Circuit.....	5-108

5.23.6	Release.....	5-110
5.23.7	Terminate and Leave Access.....	5-111
5.24	Checking the Time Slot Map	5-113
5.25	Recording the Time Slot Configuration	5-115
5.26	Redundant Operations	5-117
5.27	Power Supply Redundancy	5-117
5.28	CPU Card Redundancy	5-119
5.29	WAN Card Redundancy	5-121
5.29.1	Cross-Connect WAN Card Redundancy Switching.....	5-121
5.30	ADPCM Card Redundancy	5-125

Chapter 6 System Testing and Diagnostics

6.1	Introduction	6-1
6.2	Integral Test Capabilities	6-1
6.3	User Card Diagnostics	6-2
6.3.1	WAN Diagnostics.....	6-2
6.3.2	Voice Diagnostics.....	6-3
6.3.3	Data Diagnostics.....	6-4
6.4	System with Cross-Connect Option	6-6
6.4.1	Circuit Diagnostics	6-6
6.5	Benefits of Built-In Diagnostics	6-8
6.6	Performance Monitoring	6-11
6.6.1	T1 Line Performance Monitoring.....	6-11
6.6.2	DDS Line Performance Monitoring	6-11

Volume 2 System Cards

Chapter 7 CPU Card

7.1	Introduction	7-1
7.2	CPU Card Description	7-1
7.2.1	CPU XCON with Ethernet Port (880770).....	7-1
7.2.1.1	Card Jumper/Switch Settings	7-3
7.2.1.2	Installing the CPU-7 XCON with Ethernet Port Card	7-3
7.2.1.3	Setting Up CPU Ethernet Port.....	7-4
7.3	CPU Card User Screens and Settings	7-6
7.3.1	CPU Card Main Screen	7-6
7.3.2	RADIUS Authentication	7-7
7.3.3	User Names, Passwords and Groups	7-10
7.3.3.1	Changing Your Passwords	7-10
7.3.3.2	Other CPU Card Settings	7-13
7.3.4	Printing Alarms Remotely	7-15
7.4	TCP/IP Network Management	7-20

Table of Contents

7.4.1	SYSLOG	7-26
7.4.2	Network Statistics Screens.....	7-30
7.4.2.1	SLIP Parameters	7-31
7.4.2.2	FDL Parameters	7-32
7.4.2.3	IP Parameters	7-33
7.4.2.4	ICMP Parameters.....	7-35
7.4.2.5	TCP State Parameters	7-36
7.4.2.6	UDP Parameters	7-39
7.4.2.7	TELNET Parameters	7-40
7.4.2.8	SNMP Parameters.....	7-41
7.5	IP Packet Routing	7-42
7.5.1	nX64 Screen.....	7-49
7.5.2	Network Statistics Screen	7-52
7.6	CPU Host Software Upgrade Procedure	7-53
7.6.1	Equipment Requirements.....	7-53
7.6.2	Laptop Setup	7-53
7.6.2.1	Log Upgrade Activity	7-54
7.7	Upgrades	7-54
7.7.1	Upgrades Preparation.....	7-54
7.7.2	Software Download Procedures.....	7-55
7.7.2.1	High-level upgrade overview:	7-55
7.7.3	Detailed upgrade procedure:	7-55
7.7.3.1	XMODEM Protocol Binary Download	7-55
7.7.3.2	Pre-TFTP Binary Upload/Download Preparation	7-56
7.7.3.3	TFTP Protocol Bin Download	7-57
7.8	CPU Card Error Messages	7-60
7.9	CPU Card Troubleshooting	7-60
7.10	CPU Card Specifications	7-61

Chapter 8 Interface Card

8.1	Introduction	8-1
8.2	Interface Card Descriptions	8-1
8.2.1	INTF-R Ext Card Description (893270).....	8-1
8.2.1.1	Card Jumper/Switch Settings.....	8-2
8.2.1.2	Installing the INTF-R Ext Card	8-2
8.2.1.3	External Sync daughter card.....	8-2
8.2.1.4	Equipment Grounding Requirements	8-3
8.2.2	INTF-R Modem Card Description (893370)	8-5
8.2.2.1	Card Jumper/Switch Settings.....	8-5
8.2.2.2	Installing the INTF-R Modem Card	8-5
8.2.3	INTF-R Card Description (893470)	8-6
8.2.3.1	Card Jumper/Switch Settings.....	8-6
8.2.3.2	Installing the INTF-R Card.....	8-6
8.3	Interface Card User Screens and Settings	8-7
8.3.1	Interface Card Main Screen	8-7
8.3.1.1	Setting the System Date and Time	8-8

8.3.1.2	Selecting the System Timing Clocks	8-10
8.3.2	Call Profile Screen.....	8-13
8.3.3	Signaling Conversion Table Screen	8-18
8.3.4	Remote IMACS Terminal System (RITS)	8-19
8.3.4.1	Identification	8-19
8.3.4.2	Network Priorities	8-20
8.3.4.3	Intra-Network Communications.....	8-20
8.3.4.4	Terminal Security	8-21
8.3.5	Ports Screen	8-22
8.3.6	Interface Card Ports and Functionality	8-24
8.3.7	Using the Node Port	8-24
8.4	Interface Card Error Messages	8-26
8.5	Interface Card Troubleshooting	8-26
8.5.1	User Interface Problems	8-26
8.5.2	Alarm Reporting Problems.....	8-27
8.5.3	WAN Transmission Problems.....	8-27
8.6	Interface Card Specifications	8-28

Chapter 9 WAN Card

9.1	Introduction	9-1
9.2	WAN Card Descriptions	9-1
9.2.1	WAN DUAL Card with CSU Support Description (801070).....	9-1
9.2.1.1	Card Jumper/Switch Settings	9-2
9.2.1.2	WAN Software Level.....	9-4
9.2.1.3	WAN Software Download	9-5
9.2.2	WAN DUAL Card Description (801060, 801065)	9-11
9.2.2.1	Card Jumper/Switch Settings	9-12
9.2.3	WAN-R Card Description (801460)	9-12
9.2.3.1	Card Jumper/Switch Settings	9-13
9.2.4	WAN-R Card Description (801470)	9-13
9.2.4.1	Card Jumper/Switch Settings	9-13
9.2.4.2	WAN Software Level.....	9-13
9.3	WAN Module Descriptions	9-13
9.3.1	DSX/CEPT Module Description (81130)	9-13
9.3.1.1	DSX/CEPT Module Jumper Settings	9-14
9.3.1.2	DSX/CEPT Module Installation.....	9-14
9.3.1.3	DSX/CEPT Module.....	9-16
9.3.2	CSU Module Description (81230).....	9-18
9.3.2.1	CSU Module Installation.....	9-18
9.3.2.2	CSU Module Jumper/Switch Settings.....	9-18
9.3.3	Installing the WAN Cards	9-18
9.3.3.1	WAN-rr alarms.....	9-18
9.4	WAN Card User Screens and Settings	9-20
9.4.1	T1 CSU and DSX Settings	9-20
9.4.2	E1 CEPT Settings	9-30
9.4.3	Cross-Connect (XCON)	9-36

Table of Contents

9.4.4	Performance Data	9-38
9.4.5	Far-End Performance Data	9-41
9.4.6	Test Screen.....	9-44
9.5	WAN Card Error Messages	9-47
9.6	WAN Card Troubleshooting	9-47
9.7	WAN Card Specifications	9-48

Chapter 10 Alarm Cards

10.1	Introduction	10-1
10.2	Alarm Card Descriptions	10-1
10.2.1	ALR 4+4 Card Description (840160)	10-1
10.2.1.1	Card Jumper/Switch Settings.....	10-2
10.2.1.2	Installing the Alarm Card	10-2
10.3	Alarm Card User Screens and Settings	10-3
10.3.1	Alarm Filter Screen Sensor Setting	10-3
10.3.2	ALR 4+4 Card Main Screens.....	10-4
10.4	Alarm Card Error Messages	10-6
10.5	Alarm Card Troubleshooting	10-6

Volume 3 Voice Cards

Chapter 11 E&M Card

11.1	Introduction	11-1
11.2	E&M Card Descriptions	11-1
11.2.1	E&M 2W*8 Card Description (810860)	11-1
11.2.1.1	Card Jumper/Switch Settings.....	11-2
11.2.1.2	Installing the E&M 2W*8 Card.....	11-4
11.2.2	E&M 4W*8 ER Card Description (811960)	11-4
11.2.2.1	Card Jumper/Switch Settings.....	11-4
11.2.2.2	Installing the E&M 4W*8 ER Card	11-4
11.3	E&M Card User Screens and Settings	11-5
11.3.1	E&M Card Main Screen	11-5
11.3.2	Test Screen.....	11-11
11.3.3	Loopback Screen.....	11-16
11.4	E&M Card Error Messages	11-18
11.4.1	E&M Card Troubleshooting	11-18
11.5	E&M Card Specifications	11-20

Chapter 12 FXS Card

12.1	Introduction	12-1
12.2	FXS Card Description	12-1

- 12.2.1 FXS 2W*8-6 Card Description (812960)..... 12-1
- 12.2.1.1 Card Jumper/Switch Settings 12-2
- 12.2.1.2 Installing the FXS 2W*8-6 Card..... 12-3
- 12.3 FXS Card User Screens and Settings 12-3
- 12.3.1 FXS Card Main Screen..... 12-3
- 12.3.2 Test Screen 12-13
- 12.4 FXS Error Messages 12-18
- 12.5 FXS Card Troubleshooting 12-18
- 12.6 FXS Card Specifications 12-20

Chapter 13 FXO Card

- 13.1 Introduction 13-1
- 13.2 FXO Card Descriptions 13-1
- 13.2.1 FXO 2W*8-6 Card Description (813970)..... 13-1
- 13.2.1.1 Card Jumper/Switch Settings 13-2
- 13.2.1.2 Installing the FXO 2W*8-6 Card..... 13-2
- 13.3 FXO Card User Screens and Settings 13-3
- 13.3.1 FXO Card Main Screen..... 13-3
- 13.3.2 Test Screen 13-11
- 13.4 FXO Card Error Messages 13-16
- 13.5 FXO Card Troubleshooting 13-16
- 13.6 FXO Card Specifications 13-18

Volume 4 Data Cards

Chapter 14 HSU Card

- 14.1 Introduction 14-1
- 14.2 HSU Card Description 14-1
- 14.2.1 Two-Port HSU530/35 Card Description (820260)..... 14-1
- 14.2.1.1 Two-Port HSU Card Jumper/Switch Settings..... 14-2
- 14.2.1.2 Installing the Two-Port HSU 530/35 Card..... 14-2
- 14.2.2 HSU-T V11 Card Description (820360) 14-3
- 14.2.2.1 HSU-T V11 Card Jumper/Switch Settings..... 14-3
- 14.2.2.2 Installing the HSU-T V11 Card 14-3
- 14.2.3 HSU 35 Card Description (821260)..... 14-3
- 14.2.3.1 HSU 35 Card Jumper/Switch Settings 14-3
- 14.2.3.2 Installing the HSU 35 Card 14-3
- 14.2.4 HSU-AD 530/35 Card Description (821360)..... 14-4
- 14.2.4.1 HSU-AD Card Jumper/Switch Settings 14-4
- 14.2.4.2 Installing the HSU-AD 530/35 Card..... 14-5
- 14.2.5 HSU-T V35 Card Description (821460) 14-6
- 14.2.5.1 HSU-T V35 Card Jumper/Switch Settings..... 14-6

Table of Contents

14.2.5.2	Installing the HSU-T V35 Card.....	14-7
14.2.6	Four-Port HSU 530/35 Card Description (821570).....	14-7
14.2.6.1	Four-Port HSU Card Jumper/Switch Settings	14-7
14.2.6.2	Installing the Four-Port HSU 530/35 Card.....	14-8
14.2.7	Four-Port HSU*4E 530/35 Card Description (821660)	14-9
14.2.7.1	Features of the Four-Port HSU*4E 530/35 Card (821660).....	14-9
14.2.7.2	Four-Port HSU Card Jumper/Switch Settings	14-9
14.2.7.3	Installing the Four-Port HSU*4E 530/35 Card	14-10
14.2.8	V.35 Personality Module (1251)	14-11
14.2.9	RS-232-E Personality Module Description (1253).....	14-12
14.2.10	HSU Card Cables	14-13
14.3	HSU Card User Screens and Settings	14-14
14.3.1	HSU Card Main Screen	14-14
14.3.2	HSU Card Test Screen	14-25
14.3.3	HSU Dial Screen.....	14-30
14.3.4	HSU Call Profile Screen	14-33
14.3.5	Broadcast Screen.....	14-38
14.3.6	Broadcast Connection Status Screen	14-40
14.3.7	Inverse Multiplexer (IMUX) Screen.....	14-41
14.3.8	Dialing with High Speed Data Cards.....	14-44
14.3.8.1	Basic HSU Dialing	14-44
14.3.8.2	RS366 and V.25bis HSU Dialing.....	14-44
14.3.9	Master Dialing	14-44
14.3.10	Dialing with RS366 Commands	14-45
14.3.10.1	Command Types.....	14-45
14.3.10.2	Escape Character	14-46
14.3.11	Basic Dialing Changes.....	14-46
14.3.11.1	Example	14-47
14.3.12	Call Profile Loading.....	14-47
14.3.13	Loopback Management.....	14-48
14.3.14	Call Profile Changes	14-48
14.3.14.1	Example	14-49
14.3.15	Master Dialing	14-49
14.3.16	V.25bis Dialing.....	14-50
14.3.17	The CRN Command	14-51
14.3.18	The SCT Parameter.....	14-51
14.3.19	The BWR Parameter.....	14-51
14.3.19.1	Example	14-51
14.3.20	The CRS Command	14-51
14.3.20.1	Example	14-52
14.3.21	The DIC Command.....	14-52
14.3.22	The CIC Command	14-52
14.3.23	The INC Indication	14-52
14.3.24	The VAL Indication.....	14-52
14.3.25	The INV Indication.....	14-52
14.3.26	Performance Data	14-52
14.4	HSU Card Error Messages	14-55
14.5	HSU Card Troubleshooting	14-55

14.6 HSU Card Specifications 14-56

Chapter 15 OHSU Cards

15.1 Introduction 15-1
15.2 OHSU Card Description 15-1
15.2.1 Four-Port OHSU Card Description (823870, 823875)..... 15-1
15.2.1.1 Installing the Four-Port OHSU Card..... 15-2
15.2.2 Two-Port OHSU Card Description (823760)..... 15-2
15.2.2.1 Installing the Two-Port OHSU Card..... 15-3
15.2.3 OHSU card cables 15-3
15.3 OHSU Card User Screens and Settings 15-4
15.3.1 OHSU Card Main Screen 15-4
15.4 OHSU Card Specification 15-9

Chapter 16 SRU Card

16.1 Introduction 16-1
16.2 SRU Card Descriptions 16-1
16.2.1 SRU 232*10 Card Description (822060) 16-1
16.2.1.1 Card Jumper/Switch Settings 16-2
16.2.1.2 Installing the SRU 232*10 Card 16-2
16.2.2 SRU 232*10 C&D Bus Card Description (822160) 16-3
16.2.2.1 Card Jumper/Switch Settings 16-3
16.2.2.2 Installing the SRU 232*10 C&D Bus Card 16-3
16.2.3 LD-SRU*10 Card Description (822570)..... 16-4
16.2.3.1 Card Jumper/Switch Settings 16-5
16.2.3.2 Installing the LD-SRU*10 Card..... 16-5
16.2.4 SRU-LD*10 Card Description (822560)..... 16-6
16.2.4.1 Card Jumper/Switch Settings 16-6
16.2.4.2 Installing the SRU-LD*10 Card..... 16-7
16.3 SRU Card User Screens and Settings 16-7
16.4 Card Configuration Examples 16-17
16.5 Test Screen 16-19
16.6 SRU Card Error Messages 16-24
16.7 SRU Card Troubleshooting 16-24
16.8 SRU Card Specifications 16-26

Chapter 17 OCU-DP Card

17.1 Introduction 17-1
17.2 OCU-DP Card Descriptions 17-1
17.2.1 OCU-DP 5 Card Description (824160) 17-1
17.2.1.1 Card Jumpers/Switch Settings..... 17-1
17.2.1.2 Installing the OCU-DP 5 Card 17-2
17.2.2 OCU-DP 2 Card Description (8249) 17-2

Table of Contents

17.2.2.1	Card Jumpers/Switch Settings	17-2
17.2.2.2	Installing the OCU-DP 2 Card.....	17-2
17.2.3	OCU-DP 10 Card Description (824660)	17-2
17.2.3.1	Card Jumpers/Switch Settings	17-2
17.2.3.2	Installing the Card	17-2
17.3	OCU-DP Card User Screens and Settings	17-3
17.3.1	OCU-DP Card Main Screen	17-3
17.3.2	Performance Data Screen.....	17-11
17.3.3	Test Screen.....	17-14
17.4	OCU-DP Card Error Messages	17-18
17.5	OCU-DP Card Troubleshooting	17-18
17.6	OCU-DP Card Specifications	17-19

Chapter 18 DS0-DP Card

18.1	Introduction	18-1
18.2	DS0-DP Card Description	18-1
18.2.1	DS0-DP 4 Card Description (825460).....	18-1
18.2.1.1	Card Jumper/Switch Settings.....	18-1
18.2.1.2	Installing the Card	18-1
18.3	DS0-DP Card User Screens and Settings	18-2
18.3.1	DS0-DP Card Main Screen.....	18-2
18.4	DS0-DP Card Error Messages	18-6
18.5	DS0-DP Card Troubleshooting	18-6
18.6	DS0-DP Card Specifications	18-7

Volume 5 Server Cards

Chapter 19 ADPCM Card

19.1	Introduction	19-1
19.2	ADPCM Card Descriptions	19-1
19.2.1	ADPCM 64 Card Description (887170)	19-1
19.2.1.1	Card Jumper/Switch Settings.....	19-2
19.2.1.2	Installing the ADPCM Card	19-2
19.3	ADPCM Card User Screens and Settings	19-3
19.3.1	ADPCM Card Main Screen	19-3
19.4	ADPCM Card Error Messages	19-7
19.5	ADPCM Card Troubleshooting	19-7
19.6	ADPCM Server Card Specifications	19-8

Chapter 20 Analog Bridging Server Card

20.1	Introduction	20-1
------	--------------------	------

20.2	Analog Bridging Server Card Description (885070)	20-1
20.2.0.1	Card Jumper/Switch Settings	20-2
20.2.0.2	Installing the Analog Bridge Server Card	20-2
20.3	Analog Bridge Server Card User Screens and Settings	20-3
20.3.1	Analog Bridge Provisioning	20-3
20.3.2	Analog Bridge Server Card Main Configuration Screen	20-3
20.3.3	Port Provisioning on the Bridge	20-6
20.3.4	All ports Screen	20-10
20.4	Analog Bridge Server Card Specifications	20-14

Chapter 21 IPR*4 Router Card

21.1	Introduction	21-1
21.2	IPR*4 Router Card Descriptions	21-1
21.2.1	IPR*4 Router 10/100BT Card Description (PRM-883270).....	21-1
21.2.1.1	Card Jumpers/Switch Settings.....	21-3
21.2.2	Installing the IPR*4 Cards.....	21-3
21.3	IPR*4 configuration in a PPP or HDLC Network	21-4
21.3.1	IPR*4 Connecting IP LANs	21-4
21.4	IPR*4 Card Configuration Screens and Settings	21-5
21.4.1	IMACS Main Screen	21-5
21.4.2	IMACS Management Through the IPR*4 Card.....	21-6
21.4.3	IPR*4 10/100BT (883270) Card Main Screen.....	21-6
21.4.4	IPR*4 provisioning card setup	21-8
21.5	IPR*4 Card Download	21-10
21.5.1	tftp and xmodem upgrades	21-11
21.5.2	xpress upgrade option.....	21-15
21.6	IPR*4 Card Alarm and Upgrade Events	21-19
21.7	IPR*4 Card Troubleshooting	21-19
21.8	Introduction	21-21
21.9	IPR*4 configuration in a PPP Network	21-23
21.9.1	IPR*4 Connecting IP LANs	21-23
21.10	IPR*4PPP Configuration Screens and Settings	21-24
21.10.1	IPR*4 10/100BT (883270) Card Main Screen.....	21-24
21.10.2	IPR*4 provisioning card setup	21-26
21.10.3	IPR*4 INTF NAME screen.....	21-27
21.10.4	IPR*4 Ethernet Connectivity Screen.....	21-28
21.10.4.1	IPR*4 Ethernet Connectivity Screen - Perf.....	21-31
21.10.4.2	IPR*4 Ethernet Connectivity Screen - ARP	21-31
21.10.5	IPR*4 Port Screen	21-32
21.10.6	IPR*4 Static Route Screen	21-36
21.11	Introduction	21-38
21.12	IPR*4 configuration in a HDLC Network	21-40
21.12.1	IPR*4 Connecting IP LANs	21-40
21.13	IPR*4HDLC Configuration Screens and Settings	21-41
21.13.1	IPR*4 10/100BT (883270) Card Main Screen.....	21-41
21.13.2	IPR*4 provisioning card setup	21-43

Table of Contents

21.13.3	IPR*4 INTF NAME screen	21-44
21.13.4	IPR*4 Ethernet Connectivity Screen	21-45
21.13.4.1	IPR*4 Ethernet Connectivity Screen - Perf	21-48
21.13.4.2	IPR*4 Ethernet Connectivity Screen - ARP	21-48
21.13.5	IPR*4 Port Screen.....	21-49
21.13.6	IPR*4 Static Route Screen.....	21-54
21.14	IPR*4 Server Card Specifications	21-56

Chapter 22 MCC Card

22.1	Introduction	22-1
22.2	ACS-MCC Card Descriptions	22-1
22.2.1	ACS-MCC Card Description (881360)	22-1
22.2.1.1	Jumper/Switch Settings	22-2
22.2.1.2	Installing the Card	22-2
22.3	ACS-MCC Card User Screens and Settings	22-3
22.3.1	ACS-MCC Card Main Screen (Ethernet Port Configuration)	22-3
22.3.1.1	C-Port and Numbered Port Configuration (1.1 Version Only)	22-7
22.4	Network Port Statistics Screen	22-11
22.4.1	MCC Protocol Stack Data Screen.....	22-13
22.5	ACS-MCC Card Error Messages	22-16
22.6	ACS-MCC Card Troubleshooting	22-16

Volume 6 Appendices

Appendix A System Standards and Specifications

A.1	Introduction	A-1
A.2	Standards Compatibility	A-2
A.3	Chassis Standards	A-9
A.3.1	Dimensions	A-9
A.3.2	Chassis Power	A-10
A.3.3	Environment.....	A-10
A.3.3.1	Ambient Temperature and Humidity	A-10
A.3.3.2	Altitude	A-10
A.3.3.3	Airflow.....	A-11
A.3.3.4	Fire Resistance.....	A-11
A.3.4	Equipment Handling	A-11
A.3.4.1	Packaged Equipment Shock Criteria	A-11
A.3.4.2	Unpackaged Equipment Shock Criteria	A-11
A.3.5	Earthquake, Office Vibration and Transportation Vibration	A-11
A.3.5.1	Earthquake	A-11
A.3.5.2	Office Vibration.....	A-11
A.3.5.3	Transportation Vibration	A-11

Table of Contents

A.3.6	Cable/Power Connections	A-12
A.3.7	Mounting	A-12
A.3.7.1	Types	A-12
A.3.7.2	Clearance	A-12
A.3.8	Number of Slots	A-12
A.4	System Power Supplies and Converters	A-13
A.4.1	Power Supply Compatibility	A-15
A.4.2	External Talk Battery Fuses	A-15
A.5	Card Specifications	A-16
A.5.1	Current in milliamperes, weight and power consumption.....	A-16
A.5.2	Pre-Installation Card Setup.....	A-17
A.6	FCC Requirements	A-18
A.7	UK Requirements	A-19
A.8	Year 2000 Compliance	A-19
A.8.1	Service requirements	A-19
A.9	Safety Information and Precautions	A-20
A.9.1	Disclaimer for Shielded Cables	A-21
A.9.2	Panel and Cover Removal	A-21
A.9.3	Power Source.....	A-22
A.9.4	Fusing	A-22
A.10	Power Supply Safety Information	A-22
A.10.1	Grounding.....	A-22
A.10.2	Electrostatic Discharge Prevention.....	A-23
A.10.3	Operator Services Requirements	A-23
A.11	Regulatory Compliance Information	A-23
A.11.1	FCC Part 68 Information	A-23
A.11.2	CE Marking	A-24
A.11.3	Declaration of Conformity	A-24
A.12	Country-Specific Regulatory Compliance Information	A-25
A.12.1	Canada	A-25
A.12.1.1	Canadian DOC Information	A-25
A.12.2	Japan	A-26
A.12.2.1	Class A ITE Notification.....	A-26
A.12.3	Europe.....	A-26
A.12.3.1	European Telecommunication Approvals.....	A-26
A.12.4	United Kingdom	A-26
A.12.4.1	UK Approval Number.....	A-26
A.12.4.2	UK Compliance Statements	A-27
A.12.5	Germany	A-28
A.12.5.1	German Approval Number.....	A-28

Appendix B Error Messages

B.1	Error Messages Introduction	B-1
-----	-----------------------------------	-----

Table of Contents

Appendix C Pinouts

C.1	Introduction	C-1
C.2	CPU Card	C-2
C.2.1	CPU Card (880770)	C-2
C.2.1.1	CPU External Connector and Pinouts	C-2
C.3	Interface Cards	C-4
C.3.1	INF-R EXT Card (893270).....	C-4
C.3.1.1	INF-R External Connector and Pinouts.....	C-4
C.3.2	INF-R MODEM Card (893370)	C-12
C.3.2.1	INF-R MODEM Card External Connector and Pinouts.....	C-12
C.3.3	INF-R Card (893470).....	C-19
C.3.3.1	INF Card External Connector and Pinouts	C-19
C.4	Alarm Cards	C-25
C.4.1	ALR 4+4 Card (840160).....	C-25
C.4.1.1	ALR 4+4 Card External Connectors and Pinouts.....	C-25
C.5	E&M Cards	C-26
C.5.1	E&M 2W*8 Card (810860)	C-26
C.5.1.1	E&M 2W*8 Card External Connectors and Pinouts	C-26
C.5.2	E&M 4W*8ER Card (811960)	C-27
C.5.2.1	E&M 4W*8ER Card External Connectors and Pinouts	C-27
C.6	FXS Cards	C-29
C.6.1	FXS 2W*8-6 Card (812960).....	C-29
C.6.1.1	FXS 2W*8-6 Card External Connectors and Pinouts	C-29
C.7	FXO Cards	C-30
C.7.1	FXO 2W*8-6 Card (813970).....	C-30
C.7.1.1	FXO 2W*8-6 Card External Connector and Pinouts	C-30
C.8	HSU Cards	C-31
C.8.1	Two-Port HSU530/35 Card (820260).....	C-31
C.8.1.1	Two-Port HSU Card External Connectors and Pinouts.....	C-31
C.8.2	HSU-T V11 Card (820360)	C-33
C.8.2.1	HSU-T V11 Card External Connectors and Pinouts	C-33
C.8.3	HSU 35 Card (821260)	C-35
C.8.3.1	HSU 35 Card External Connectors and Pinouts	C-35
C.8.4	HSU-AD 530/35 Card (821360).....	C-36
C.8.4.1	HSU-AD 530/35 Card External Connectors and Pinouts.....	C-36
C.8.5	HSU-T V35 Card (821460)	C-39
C.8.5.1	HSU-T V35 Card External Connectors and Pinouts	C-39
C.8.6	Four-Port HSU 530/35 Card (821570)	C-41
C.8.6.1	Four-Port HSU 530/35 Card External Connectors and Pinouts	C-41
C.8.7	Four-Port HSU*4E 530/35 SS Card (821660)	C-43
C.8.7.1	Four-Port HSU*4E 530/35 SS Card Connector Pinouts	C-43
C.8.8	HSU Card Cables.....	C-45
C.9	OHSU Cards	C-47
C.9.1	OHSU 2-port Card (823760)	C-47
C.9.1.1	OHSU Card External Connector and Pinouts.....	C-47
C.9.2	OHSU 4-Port Card (823870 / 823875)	C-48
C.9.2.1	OHSU Card External Connector and Pinouts.....	C-48

- C.10 SRU Cards C-49
 - C.10.1 SRU 232*10 Card (822060)..... C-49
 - C.10.1.1 SRU 232*10 Card External Connector and Pinouts C-49
 - C.10.2 SRU 232*10 C&D Bus Card (822160)..... C-51
 - C.10.2.1 SRU 232*10 C&D Bus Card External Connector and Pinouts C-51
 - C.10.3 SRU-LD*10 Card (822560 / 822570)..... C-53
 - C.10.3.1 SRU-LD*10 Card External Connector and Pinouts..... C-53
- C.11 OCU-DP Cards C-55
 - C.11.1 OCU-DP 2 Card (8249)..... C-55
 - C.11.1.1 OCU-DP 2 Card External Connectors and Pinouts..... C-55
 - C.11.2 OCU-DP 5 Card (824160)..... C-57
 - C.11.2.1 OCU-DP 5 Card External Connectors and Pinouts..... C-57
 - C.11.3 OCU-DP 10 Card (824660)..... C-59
 - C.11.3.1 OCU-DP 10 Card External Connectors and Pinouts..... C-59
- C.12 DS0-DP Cards C-61
 - C.12.1 DS0-DP 4 Card (825460)..... C-61
 - C.12.1.1 DS0-DP 4 Card External Connector and Pinouts..... C-61
- C.13 Server Cards C-63
 - C.13.1 ACS-MCC Server Card (881360)..... C-63
 - C.13.1.1 ACS-MCC External Connectors and Pinouts C-63
 - C.13.2 IPR*4 10/100 BT Card (883270)..... C-64
 - C.13.2.1 IPR*4 10/100 BT Card External Connectors and Pinouts C-64

Appendix D Node Management Provisioning Examples

- D.1 Introduction D-1
 - D.1.1 Remote Management of IMACS using the E1 SA4 bit D-1
 - D.1.1.1 Setting up the Local IMACS to Provide Remote Access..... D-2
 - D.1.1.2 Setting up the Remote IMACS to Provide Remote Access D-3
 - D.1.2 Remote Management of an IMACS Using DS0 Daisy-Chaining D-4
 - D.1.2.1 Setting up the Local IMACS for Ethernet Hosting D-4
 - D.1.2.2 Setting up the Transport IMACS for DS0 Daisy-Chaining D-5
 - D.1.2.3 Setting up the Termination IMACS for DS0 Daisy-Chaining D-6

Appendix E Glossary

Index1

Table of Contents

List of Figures

2-1	Mounting Holes for Front-Loading Chassis with Power Supplies on the Side	2-4
2-2	Mounting Bracket Holes	2-5
2-3	Mounting Holes for Front-Loading Chassis with Power Supplies on Top.....	2-6
2-4	Two-Sided Chassis Mounting Holes	2-7
2-5	JP1 Jumper Settings	2-9
2-6	-48V Converter Fuse.....	2-11
2-7	105V Ringing Generator Jumper Setting.....	2-13
2-8	Front-Loading Chassis Power Supplies on the Side in a DC Environment.....	2-15
2-9	Front-Loading Chassis Power Supplies on the Side in a AC Environment.....	2-16
2-10	Two-Sided Chassis Power Supplies on the Side in a DC Environment	2-18
2-11	Two-Sided Chassis Power Supplies on the Side in a AC Environment	2-19
2-12	Enhanced Chassis Power Supplies on Top DC Environment - one Power Source	2-21
2-13	Enhanced Chassis Power Supplies on Top in an AC Environment with an -48VDC AC/DC Converter for Voice or Data Applications.....	2-22
2-14	Terminal Connector Types	2-25
2-15	Two-Sided or Front-Loading Supplies on Side Ground Strap Methods	2-25
2-16	Front-Loading Chassis Supplies on Top Ground Strap Methods	2-26
2-17	External -48VDC Power and Ground to Terminal Block.....	2-26
2-18	AC Ground Connections to Terminal Block	2-27
2-19	Ground Connections for External PSU on Smaller Terminal Strip.....	2-27
2-20	Ground Connections on Smaller Terminal Strip	2-28
2-21	Ground Connections to External PSU Large Terminal Strip	2-29
2-22	Ground Connections for Large Terminal Strip.....	2-29
2-23	Ground Methods with External Ring Generator.....	2-30
2-24	Ground Strap Methods with External Ring Generator	2-31
3-1	Front-Loading 891630 Chassis with Power Supplies on the Side.....	3-2
3-2	Two-Sided Chassis Front View (891830)	3-4
3-3	Rear View of Two-Sided 891830 Chassis	3-5
3-4	Power Enhanced Chassis (891930).....	3-7
3-5	External Power Source for the Power Enhanced Chassis (891930)	3-8
3-6	Power Supply and Ringer Supports for Power Enhanced Chassis (891930)	3-9
4-1	An IAD used as a Voice Channel Bank.....	4-5
4-2	IAD using TR008.....	4-6
4-3	IAD using T1/E1 Conversion	4-7
4-4	Point to MultiPoint One-Way Video and Audio using HSUs	4-10
4-5	IAD with SRU Card Application.....	4-12
4-6	IAD using ADPCM for PBX to PBX Application	4-17
4-7	MCC Card in a Multilevel Concentration Application.....	4-20
4-8	IP Routing Server for Internet or Intranet Based Services	4-22
4-9	Private Intranet Deployment using IP Routing Server Card.....	4-23
5-1	First Time Registration Screen	5-3
5-2	First Time Login Screen	5-4

List of Figures

5-3	Welcome to Registration Screen	5-5
5-4	Selecting Chassis Type Screen.....	5-6
5-5	Testing and Initialization Screen.....	5-7
5-6	Typical Login Screen	5-8
5-7	Main Screen (Two-Sided and Front-Loading Chassis - Power Supplies on Top)	5-9
5-8	Main Screen (Front-Loading Chassis Power Supplies on the Side)	5-10
5-9	CPU screen - userNames option	5-11
5-10	User Name Screen.....	5-14
5-11	Adding a User	5-16
5-12	Login Log Sample Display	5-17
5-13	Group Permissions Settings	5-18
5-14	Typical Card Status Display.....	5-21
5-15	Typical Card Main Screen	5-24
5-16	Cold-Start NVRAM Test Screen.	5-28
5-17	Typical Alarm Screen	5-30
5-18	Alarm Filters Screen	5-31
5-19	Typical Alarm History Screen	5-36
5-20	Xcon Screen - amt Options	5-37
5-21	Alternative Mapping Table Options Screen.....	5-39
5-22	Remote AMT Main screen.....	5-40
5-23	Remote shelf with database restored.....	5-41
5-24	Active AMT main screen	5-43
5-25	Alarm Trigger selections.....	5-44
5-26	System Test and Debug Screen.....	5-46
5-27	Zip Screen	5-47
5-28	Typical E&M Card Time Slot Assignments	5-56
5-29	Typical HSU Card Time Slot Assignments for T1	5-58
5-30	Typical HSU Card Time Slot Assignments for E1	5-59
5-31	Cross Connect Screen	5-61
5-32	Cross Connect Screen -View All	5-62
5-33	Cross Connect Circuit (Rename)	5-62
5-34	Cross Connect Rename Circuit (Saving)	5-63
5-35	WAN Cross Connect Screen.....	5-63
5-36	WAN Cross Connect Screen (Rename).....	5-64
5-37	Cross Connect Screen (Rename Displayed)	5-64
5-38	NVRAM Backup Screen.....	5-65
5-39	NVRAM Restore Screen.....	5-66
5-40	E&M Provisioning screen	5-67
5-41	Name screen	5-67
5-42	Automatic Time Slot Assignment Example.....	5-68
5-43	Typical Card Slot and Type Selection	5-69
5-44	Typical WAN Card Selection	5-70
5-45	Typical System Main Screen with Alarms.....	5-71
5-46	Typical WAN Time Slot Assignment Screen	5-72
5-47	Typical CPU Cross-Connect Screen	5-73
5-48	Add a Cross-Connect Circuit Screen	5-74
5-49	New Circuit Selection and ID Assignment	5-76
5-50	WAN Unit Options	5-77

5-51	Time Slot and Bandwidth Options.....	5-78
5-52	Test Options.....	5-79
5-53	Cross-Connect Circuit Type Selection	5-81
5-54	Trunk Conditioning Option Selection.....	5-82
5-55	Signaling Bit Pattern Selection	5-84
5-56	Voice Options Screen	5-85
5-57	Selecting PCM Conversion.....	5-86
5-58	Selecting Signaling Conversion.....	5-87
5-59	Typical Completed Circuits	5-88
5-60	Updated WAN Card Screen.....	5-90
5-61	Delete Cross-Connection Screen	5-91
5-62	Typical Message on a CPU Cross-Connect Screen	5-92
5-63	Highlighted Circuit on a WAN Cross-Connect Screen	5-93
5-64	Typical Test Screen and ABCD Bit Options	5-94
5-65	Voice Test Diagram	5-95
5-66	Typical Main Cross-Connect Screen	5-97
5-67	Typical All Circuits Screen.....	5-98
5-68	Typical Add Broadcast Screen	5-99
5-69	Typical "To" Destination Selection	5-100
5-70	Typical Time Slot Selection	5-101
5-71	Typical Complete Broadcast Circuit.....	5-101
5-72	Three Broadcast Circuits	5-102
5-73	Typical Deleted Broadcast Circuit.....	5-102
5-74	The TADS screen.....	5-104
5-75	The Add Monitor Circuit Screen	5-105
5-76	Completed Monitor Circuit.....	5-106
5-77	Monitor Circuit Diagram	5-107
5-78	TADS Screen with Split Circuits.....	5-108
5-79	Split Circuit Diagram.....	5-109
5-80	TADS Restore Circuit Screen.....	5-110
5-81	TLA Circuit State Screen.....	5-111
5-82	Typical Time Slot Screen for T1 Operation	5-113
5-83	Typical Time Slot Screen in E1 Operation.....	5-114
5-84	Typical Redundant-Power Supply System Main Screen.....	5-118
5-85	Manually Switching to a Redundant CPU.....	5-119
5-86	Typical System with CPU Switchover Completed.....	5-120
5-87	Typical Cross-Connect System with WAN Card Redundancy	5-122
5-88	Switching to a Redundant Cross-Connect WAN Card.....	5-123
5-89	Typical Cross-Connect WAN Card Redundancy Switch in Progress	5-124
5-90	Typical System with Redundant ADPCM Cards	5-125
5-91	Typical ADPCM Card Main Screen.....	5-126
5-92	Typical ADPCM Card Redundancy Switch in Progress	5-127
6-1	Built-In Diagnostics Example (Diagnostics 1 - 4).....	6-9
6-2	Built-In Diagnostics Example (Diagnostics 4 - 8).....	6-10
7-1	CPU-7 XCON with Ethernet Port.....	7-3
7-2	CPU Card Main Screen.....	7-6
7-3	RADIUS options.....	7-7
7-4	Login Log Sample Display	7-12

List of Figures

7-5	Typical CPU Print Alarm Screen	7-16
7-6	Typical Alarm Printout	7-19
7-7	Typical TCP/IP Network Management System	7-20
7-8	Typical TCP/IP Screen.....	7-21
7-9	CPU Default IP Port Selection Screen	7-24
7-10	CPU Default IP Unit Selection Screen.....	7-25
7-11	SYSLOG server level.....	7-27
7-12	SYSLOG level	7-27
7-13	SYSLOG server test log result.....	7-28
7-14	Typical Network Statistics Screen, Page 1	7-30
7-15	Typical Network Statistics Screen, Page 2	7-33
7-16	Typical Network Statistics Screen, Page 3	7-36
7-17	Typical Network Statistics Screen, Page 4	7-39
7-18	Typical Routing Diagram.....	7-43
7-19	Typical IP Routing Screen	7-44
7-20	Routing Address Entry Screen	7-46
7-21	Slot/Unit Options Screen.....	7-47
7-22	IP Static Routing Information Screen	7-48
7-23	nX64 Main Screen.....	7-49
7-24	nX64 Netstat Screen.....	7-52
7-25	CPU Programming level	7-58
8-1	INTF-R Ext Interface Card (893270).....	8-2
8-2	Jumper Arrangements for the T1/E1 External Sync Card	8-3
8-3	INTF-R Modem Interface Card (893370).....	8-5
8-4	INTF-R Interface Card (893470)	8-6
8-5	Typical Interface Card Main Screen	8-7
8-6	SNTP time server enabled.....	8-9
8-7	Typical Call Profile Screen	8-13
8-8	Signaling Conversion Table Screen	8-18
8-9	Typical RITS Configuration	8-20
8-10	Typical Ports Screen (INTF+M)	8-22
8-11	Component Layout for the INF-R Modem and INF-R Interface Cards.....	8-24
8-12	Node Port ACO Alarm Interface.....	8-25
9-1	WAN DUAL Card with CSU Support (801070)	9-2
9-2	801070 Strap Settings for T1, E1 and T1 CSU	9-3
9-3	WAN Software Level.....	9-5
9-4	WAN load 1.0.7	9-6
9-5	WAN Download screen	9-7
9-6	WAN Download Options	9-8
9-7	TFTP Download in Progress	9-9
9-8	XMODEM download screen.....	9-10
9-9	WAN DUAL Card (801060).....	9-12
9-10	Installing DSX/CEPT Modules (8010)	9-15
9-11	DSX/CEPT Module (Jumpers set forT1) (81130)	9-16
9-12	DSX/CEPT Module Jumper Settings (81130)	9-16
9-13	E1 Interface Adapter Panel (11830 or 1184)	9-17
9-14	Installing DSX/CEPT Modules	9-19
9-15	WAN Card Main Screen for T1 CSU and DSX	9-20

9-16	Line and Local Loopbacks.....	9-26
9-17	DS0 Time Slot Loopback	9-27
9-18	Using WAN Groups.....	9-29
9-19	WAN Card Main Screen for CEPT/HDSL.....	9-30
9-20	E1 Cross-Connect Screen (display only).....	9-36
9-21	T1 WAN Cross-Connect Screen (display only)	9-37
9-22	Typical Performance Data Screen	9-38
9-23	Typical Far-End Performance Data Screen	9-41
9-24	Typical WAN Card Test Screen	9-44
10-1	ALR 4+4 Card	10-2
10-2	Alarm Filter Screen.....	10-3
10-3	ALR 4+4 Card Main Screen	10-4
11-1	Typical E&M Card Switches.....	11-2
11-2	Typical E&M Card Main Screen	11-5
11-3	E&M Card Loopbacks	11-9
11-4	Typical E&M Card Test Screen.....	11-11
11-5	Typical E&M Loopback Screen	11-16
12-1	FXS 2W*8-6 Card Jumpers Settings	12-2
12-2	Typical FXS Card Main Screen.....	12-3
12-3	FXS Card Loopbacks.....	12-10
12-4	Typical FXS Card Test Screen	12-13
13-1	FXO 2W*8-6 Card Jumper Settings.....	13-2
13-2	Typical FXO Card Main Screen	13-3
13-3	FXO Card Loopbacks	13-8
13-4	Typical FXO Card Test Screen.....	13-11
14-1	Two-Port HSU 530/35 Card Switches.....	14-2
14-2	HSU-AD 530/35 Card Switches	14-4
14-3	HSU-T V35 Card	14-6
14-4	Four-Port HSU 530/35 Card Switches.....	14-8
14-5	Four-Port HSU*4E 530/35 SS Card Switches.....	14-10
14-6	V.35 Personality Module	14-11
14-7	RS-232 Personality Module.....	14-12
14-8	Typical HSU Card Main Screen	14-14
14-9	Typical HSU Port Time Slot Assignment Screen.....	14-18
14-10	Local DTE Loopback.....	14-20
14-11	Local Network Loopback	14-21
14-12	Remote OCU or DS0 Loopback	14-22
14-13	Remote CSU Loopback	14-23
14-14	Remote DSU Loopback	14-23
14-15	Typical HSU Card Test Screen.....	14-25
14-16	HSU Dial Screen.....	14-30
14-17	HSU Card Call Profile Screen	14-34
14-18	HSU Broadcast Function	14-38
14-19	HSU Broadcast Screen.....	14-39
14-20	Call Profile Broadcast Screen	14-40
14-21	IMUX Call Screen	14-41
14-22	Typical HSU Performance Data Screen	14-53
15-1	4-Port OHSU Card.....	15-2

List of Figures

15-2	Two-Port OHSU Card.....	15-3
15-3	Typical OHSU Card Main Screen.....	15-4
15-4	Typical OHSU Port Time Slot Assignment Screen	15-6
15-5	Local User Loopback	15-7
15-6	Local Network Loopback.....	15-8
16-1	SRU 232*10 Jumper Settings	16-2
16-2	SRU 232*10 C&D Bus Jumper Settings	16-3
16-3	PRM-822570 LD-SRU board	16-5
16-4	PRM-822560 SRU-LD*10 Card Jumper Settings	16-6
16-5	Typical SRU Card Main Screen.....	16-7
16-6	SRU Time Slot Integration.....	16-11
16-7	Local Loopbacks	16-13
16-8	Inband Remote SRU Loopback	16-14
16-9	Inband Remote CSU Loopback	16-14
16-10	Inband Remote DSU Loopback	16-14
16-11	Typical WAN Time Slot Assignments to an SRU Card	16-18
16-12	Typical SRU Card Test Screen	16-19
17-1	Typical OCU-DP Card Main Screen.....	17-3
17-2	Data Frames, Rates, and Time Slot Assignments	17-6
17-3	OCU Local Loopback (dte option)	17-8
17-4	OCU Local Loopback (net-a option)	17-9
17-5	OCU Local Loopback (net-d option)	17-9
17-6	OCU Remote Loopback (ds0-n and ocu-n options).....	17-10
17-7	OCU Remote Loopback (csu-n option)	17-10
17-8	OCU Remote Loopback (csu-u option)	17-10
17-9	Typical Performance Data Screen.....	17-12
17-10	Typical OCU-DP Card Test Screen	17-14
18-1	Typical DS0-DP Card Main Screen	18-2
19-1	Typical ADPCM Card Main Screen	19-3
20-1	Analog Bridge Server.....	20-2
20-2	Analog Bridge Server main screen	20-3
20-3	Configuring a bridge - bridge 5.....	20-5
20-4	Bridge Port Screen	20-6
20-5	Bridge 5 - three ports in use	20-9
20-6	E&M card screen.....	20-10
20-7	Bridge All Ports command.....	20-11
20-8	Bridge 14 display - ports on the bridge.....	20-12
20-9	All ports - delete a port.....	20-13
21-1	IPR*4 Card Layout	21-3
21-2	IPR*4 Card Connected to IP LANs through a PPP Network	21-4
21-3	IPR*4 card interactions	21-5
21-4	Setting the CPU management through the IPR*4 card	21-6
21-5	IPR*4 10/100BT Card Interface Main Screen	21-7
21-6	IPR*4 download screen.....	21-11
21-7	Configuration change - reprovisioning needed.....	21-12
21-8	An in-process IPR*4 card download.....	21-13
21-9	Checksum passed, writing load to flash.	21-14
21-10	xpress download of IPR*4 card	21-15

21-11	Download Confirmation	21-16
21-12	Configuration change - reprovisioning needed.....	21-17
21-13	xpress download in Progress.....	21-17
21-14	IPR*4 Card Connected to IP LANs through a PPP Network.....	21-23
21-15	IPR*4 10/100BT Card Interface Main Screen.....	21-24
21-16	INTF Name Screen	21-27
21-17	Ethernet screen for IPR*4 card.....	21-29
21-18	IPR*4 Ethernet Performance Screen	21-31
21-19	IPR*4 10/100BT ARP Table Screen	21-32
21-20	IPR*4PPP Port Display	21-33
21-21	IPR*4 Static Route Entry.....	21-36
21-22	IPR*4HDLC IMACS node Management.....	21-40
21-23	IPR*4HDLC 10/100BT Card Interface Main Screen.....	21-42
21-24	INTF Name Screen	21-44
21-25	Ethernet screen for IPR*4 card.....	21-46
21-26	IPR*4 Ethernet Performance Screen	21-48
21-27	IPR*4 10/100BT ARP Table Screen	21-49
21-28	IPR*4HDLC Port Display	21-50
21-29	IPR*4HDLC port Performance Monitoring	21-51
21-30	IPR*4 Static Route Entry.....	21-54
22-1	Typical MCC Application	22-2
22-2	Typical ACS-MCC Card Main Screen	22-3
22-3	Typical C-Port Screen.....	22-7
22-4	Typical Numbered Port Screen.....	22-8
22-5	Typical Network Port Data Screen	22-11
22-6	Typical MCC Protocol Stack Data Screen	22-13
C-1	CPU-7 Card Connector (880770)	C-2
C-2	RJ48 Ethernet Jack.....	C-3
C-3	INF-R EXT Card Connectors (893270).....	C-4
C-4	RJ45 (COM2) Jack	C-5
C-5	RJ45 Node Jack	C-6
C-6	RJ-45 (TERM) Local Interface Jack.....	C-7
C-7	RJ45 External Sync Jack.....	C-8
C-8	Management Connector.....	C-9
C-9	NET Jack.....	C-10
C-10	INF-R Modem Card Jacks (893370)	C-12
C-11	MODEM Jack.....	C-13
C-12	RJ45 (NODE) Jack	C-14
C-13	RS232 (TERM) Local Interface Jack	C-15
C-14	Management Connector.....	C-16
C-15	NET Jack.....	C-17
C-16	INF-R Interface Card Jacks (893470).....	C-19
C-17	RJ45 (NODE) Jack	C-20
C-18	RS232 (TERM) Local Interface Jack	C-21
C-19	Management Connector.....	C-22
C-20	NET Jack.....	C-23
C-21	ALR 4+4 Card Jack	C-25
C-22	E&M 2W*8 Card Jack.....	C-26

List of Figures

C-23	E&M 4W*8ER Card Jack	C-27
C-24	FXS 2W*8-6 Card Jack	C-29
C-25	FXO 2W*8-6 Card Jack.....	C-30
C-26	Two-Port HSU 530/35 Front Panel Connectors (820260).....	C-31
C-27	Two-Port HSU 530/35 Jack Pin Orientation.....	C-32
C-28	HSU-T V11 Card Front Panel Connectors (820360).....	C-33
C-29	HSU 35 Card Jack Pin Orientation	C-35
C-30	HSU-AD 530/35 Card Jacks (821360)	C-36
C-31	HSU-AD 530/35 Card Jack Pin Orientation	C-37
C-32	HSU-AD 530/35 Card RS-366 Jack Pin Orientation.....	C-38
C-33	HSU-T V35 Card Front Panel Connectors (821460).....	C-39
C-34	HSU-T V35 Card Jack Pin Orientation.....	C-40
C-35	Four-Port HSU 530/35 Card Jacks (821560).....	C-41
C-36	Four-Port HSU*4E 530/35 SS Card Jacks (821660).....	C-43
C-37	Fiber ST connectors (823760).....	C-47
C-38	Fiber ST connectors (823870 / 823875).....	C-48
C-39	SRU 232*10 Card Jacks (822060).....	C-49
C-40	SRU 232*10 C&D Bus Card Jacks (822160).....	C-51
C-41	SRU-LD*10 Card Jacks (822560 / 822570).....	C-53
C-42	OCU-DP 2 Card Jacks	C-55
C-43	OCU-DP 5 Card Jacks (842160).....	C-57
C-44	OCU-DP 10 Card Jacks (824660).....	C-59
C-45	DS0-DP 4 Card Jacks (825460)	C-61
C-46	ACS-MCC Card Ethernet Port Jack.....	C-63
C-47	IPR*4 10/100 BT Card Ethernet Port Jack	C-64
D-1	Sample Remote Management Need - E1	D-1
D-2	Sample Remote Management Need - T1 or E1	D-4

List of Tables

1-1	Low impact Supported Card list.....	1-2
2-1	Minimum Two-Sided Chassis Clearances.....	2-7
3-1	Card Slots for Front-Loading 891630 Chassis with Power Supplies on the Side	3-3
3-2	Two-Sided Chassis Card Slots	3-6
3-3	Card Slots for Front-Loading Chassis with Enhanced Power Supplies on Top.....	3-10
5-1	User Access Table	5-11
5-2	Default User Table.....	5-11
5-3	User Accesses by Group.....	5-12
5-4	Default Group Permissions.....	5-13
5-5	usrName Screen Actions	5-15
5-6	System Main Screen Actions.....	5-20
5-7	Alarm Filters.....	5-33
5-8	Circuit Names	5-60
5-9	Time Slot Cross-Connection Options and Defaults	5-75
5-10	CPU Cross-Connect Screen Actions	5-89
5-11	WAN Cross-Connect Test Screen Options	5-94
5-12	Broadcast Screen Actions	5-103
5-13	TLA Circuit State Screen Menu of Actions	5-111
5-14	Time Slot Recording Form for T1 Operation.....	5-115
5-15	Time Slot Recording Form for E1 Operation.....	5-116
7-1	CPU Card Main Screen Actions.....	7-7
7-2	usrName Screen Actions	7-11
7-3	Print Alarm Screen Actions.....	7-16
7-4	Print Alarm Screen Options and Defaults	7-17
7-5	TCP/IP Screen Actions	7-22
7-6	TCP/IP Screen Options and Defaults	7-22
7-7	SYSLOG CPU / Loading events	7-28
7-8	SYSLOG Alarm Indications.....	7-29
7-9	SYSLOG Configuration Change Notifications	7-29
7-10	SYSLOG USER ID tracking	7-29
7-11	Network Statistics Screen Actions	7-31
7-12	Routing Screen Actions	7-44
7-13	Settings for Routing Parameters	7-45
7-14	Slot/Unit Options	7-47
7-15	nX64 Screen Actions	7-49
7-16	nX64 Screen Options and Defaults	7-50
7-17	nx64 Netstat Screen Actions.....	7-52
8-1	Jumper Settings for the T1/E1 External Sync Card.....	8-3
8-2	Interface Card Main Screen Actions	8-8
8-3	Interface Card Setting Options and Defaults	8-10
8-4	Call Profile Screen Actions	8-14
8-5	Call Profile Screen Options and Defaults.....	8-14

List of Tables

8-6	Signaling Conversion Table Screen Actions	8-19
8-7	“AT” Commands Used by RITS.....	8-21
8-8	Interface Ports and Functions.....	8-24
9-1	801070 WAN Strap Setting Options.....	9-4
9-2	T1 CSU and DSX Main Screen Actions	9-21
9-3	T1 CSU and DSX Option Settings and Defaults	9-22
9-4	DS0-to-SLC-96 Time Slot Conversion.....	9-24
9-5	AIS/ALM Settings	9-25
9-6	E1 HDSL Screen Actions	9-31
9-7	E1 Screen Option Settings and Defaults	9-32
9-8	Performance Data Screen Actions	9-39
9-9	Far-End Performance Data Screen Actions	9-42
9-10	Test Screen Actions	9-44
9-11	WAN Card Test Screen Options.....	9-45
10-1	ALR 4+4 Card Main Screen Actions.....	10-4
10-2	ALR 4+4 Card Option Settings and Defaults	10-5
11-1	Typical E&M Card Switch Definitions	11-3
11-2	Typical E&M Card Switch Settings.....	11-3
11-3	Main Screen Actions.....	11-6
11-4	Main Screen Option Settings and Defaults	11-6
11-5	Test Screen Actions	11-12
11-6	Test Screen Option Settings and Defaults.....	11-12
11-7	Status Information Field Settings.....	11-15
11-8	Loopback Screen of Actions	11-16
11-9	Loopback Screen Option Settings and Defaults	11-17
12-1	Main Screen Actions.....	12-4
12-2	Main Screen Option Settings and Defaults	12-4
12-3	Incoming Calls (1s-R2e).....	12-7
12-4	Outgoing Calls (1s-R2e).....	12-7
12-5	Incoming Calls (R1.5i).....	12-8
12-6	Outgoing Calls (R1.5o).....	12-8
12-7	Test Screen Actions	12-13
12-8	Test Screen Option Settings and Defaults.....	12-14
12-9	Status Information Field Settings.....	12-17
13-1	Main Screen Actions.....	13-4
13-2	Main Screen Option Settings and Defaults	13-4
13-3	Test Screen Actions	13-11
13-4	Test Screen Option Settings and Defaults.....	13-12
13-5	Status Information Field Settings.....	13-15
14-1	HSU to Cable Matrix (To DTE Clock).....	14-13
14-2	HSU to Cable Matrix (To DCE Clock).....	14-13
14-3	HSU Card Main Screen Actions	14-15
14-4	HSU Card Setting Options and Defaults.....	14-15
14-5	HSU Card State Status	14-16
14-6	Test Screen Actions	14-25
14-7	Test Screen Option Settings and Defaults.....	14-26
14-8	HSU Dial Screen Actions	14-31
14-9	Dial Screen Option Settings and Defaults.....	14-31

14-10	HSU Card Call Profile Screen Actions.....	14-34
14-11	HSU Card Call Profile Screen Option Settings and Defaults.....	14-35
14-12	Call Profile Broadcast Screen Actions	14-41
14-13	IMUX Call Screen Actions.....	14-42
14-14	IMUX Call Screen Option Settings and Defaults.....	14-42
14-15	Values for Service Type Field	14-46
14-16	Call Profile Parameter Numbers and Values	14-48
14-17	MUX Call Screen Actions.....	14-49
14-18	Field Values for Command Strings	14-50
14-19	Performance Data Screen Actions	14-53
15-1	OHSU Card Main Screen Actions.....	15-5
15-2	OHSU Card Setting Options and Defaults	15-5
15-3	Alarm Field.....	15-8
16-1	Main Screen Actions	16-8
16-2	Main Screen Option Settings and Defaults.....	16-8
16-3	SRU Card State Status	16-9
16-4	Bit Error Rates for Majority-Vote Error Correction.....	16-16
16-5	Test Screen Actions	16-20
16-6	Test Screen Option Settings and Defaults	16-20
17-1	Main Screen Actions	17-4
17-2	Main Screen Option Settings and Defaults.....	17-4
17-3	OCU-DP Primary and Secondary Channel Rates.....	17-7
17-4	Performance Data Screen Actions	17-13
17-5	Test Screen Actions	17-15
17-6	Test Screen Option Settings and Defaults	17-15
18-1	Main Screen Actions	18-3
18-2	Main Screen Option Settings and Defaults.....	18-3
19-1	ADPCM Compression Rates	19-2
19-2	ADPCM Card Main Screen Actions	19-4
19-3	ADPCM Card Setting Options and Defaults	19-4
20-1	Analog Bridge Main Screen Actions.....	20-3
20-2	Analog Bridge Main Screen Option Settings and Defaults	20-4
20-3	Analog Bridge Port Screen Actions.....	20-6
20-4	Analog Bridge Port Screen Option Settings and Defaults.....	20-7
21-1	IPR*4 available options.....	21-2
21-2	IPR*4 10/100BT Card Main Screen Actions	21-8
21-3	IPR*4 PPP option	21-21
21-4	IPR*4 10/100BT Card Main Screen Actions	21-26
21-5	IPR*4 Interface Name Screen Action	21-28
21-6	IPR*4 10/100BT Ethernet Menu Option Settings and Defaults.....	21-29
21-7	IPR*4 Port Menu Option Settings and Defaults.....	21-33
21-8	IPR*4 10/100BT port Menu Option Settings and Defaults.....	21-34
21-9	IPR*4 10/100BT IP Static Routes Configuration Table Screen Actions	21-36
21-10	IPR*4 available options.....	21-38
21-11	IPR*4 10/100BT Card Main Screen Actions	21-43
21-12	IPR*4 Interface Name Screen Action	21-45
21-13	IPR*4 10/100BT Ethernet Menu Option Settings and Defaults.....	21-46
21-14	IPR*4 Port Menu Option Settings and Defaults.....	21-50

List of Tables

21-15	IPR*4 10/100BT port Menu Option Settings and Defaults	21-52
21-16	IPR*4 10/100BT IP Static Routes Configuration Table Screen Actions.....	21-54
22-1	Main Screen Actions.....	22-4
22-2	Main Screen Option Settings and Defaults	22-4
22-3	Port Assignment Screen Actions.....	22-8
22-4	Port Screen Option Settings and Defaults.....	22-9
22-5	Network Port Data Screen Actions	22-13
C-1	RJ48 Ethernet Port Jack Pinouts	C-3
C-2	RJ45 (COM2) Jack Signal Pinouts	C-5
C-3	RJ45 (NODE) Jack Signal Pinouts	C-6
C-4	RJ-45 (TERM) Jack Signal Pinouts	C-7
C-5	RJ45 External (SYNC) Jack Signal Pinouts	C-8
C-6	Management Connector Signal Pinouts.....	C-9
C-7	NET Jack Signal Pinouts.....	C-11
C-8	Modem Specifications.....	C-13
C-9	RJ45 (NODE) Jack Signal Pinouts	C-14
C-10	RS232 (TERM) Jack Signal Pinouts.....	C-15
C-11	Management Connector Signal Pinouts	C-16
C-12	NET Jack Signal Pinouts.....	C-18
C-13	RJ45 (NODE) Jack Signal Pinouts	C-21
C-14	RS232 (TERM) Jack Signal Pinouts.....	C-21
C-15	Management Connector Signal Pinouts.....	C-22
C-16	NET Jack Signal Pinouts.....	C-24
C-17	ALR 4+4 Card Jack Pinouts	C-25
C-18	E&M 2W*8 Card Jack Pinouts.....	C-26
C-19	E&M 4W*8ER Card Jack Pinouts.....	C-28
C-20	FXS 2W*8-6 Card Jack Pinouts	C-29
C-21	FXO 2W*8-6 Card Jack Pinouts.....	C-30
C-22	Two-Port HSU 530/35 Jack Pinouts	C-32
C-23	HSU-T V11 Jack Pinouts.....	C-34
C-24	HSU 35 Card Jack Signal Pinouts.....	C-35
C-25	HSU-AD 530/35 Card Jack Signal Pinouts	C-37
C-26	HSU-AD 530/35 Card RS-366 Jack Pinouts	C-38
C-27	HSU-T V35 Card Jack Pinouts	C-40
C-28	Four-Port HSU 530/35 Jack Pinouts.....	C-42
C-29	Four-Port HSU*4E 530/35 SS Jack Pinouts	C-44
C-30	HSU to Cable Matrix (To DTE Clock).....	C-45
C-31	HSU to Cable Matrix (To DCE Clock).....	C-45
C-32	HSU to Cable Matrix (DCE Provides Clock).....	C-46
C-33	OHSU 2-port Card ST connector designation	C-47
C-34	OHSU Card ST connector designation	C-48
C-35	SRU 232*10 Card Jack Pinouts	C-50
C-36	SRU 232*10 C&D Bus Card Jack Pinouts	C-52
C-37	SRU-LD*10 Card Jack Pinouts	C-54
C-38	OCU-DP 2 Jack Signals Pinouts	C-56
C-39	OCU-DP 5 Jack Signals Pinouts	C-58
C-40	OCU-DP 10 Jack Signals Pinouts.....	C-60
C-41	DS0-DP 4 Card Jack Pinouts	C-62

C-42	ACS-MCC Card Ethernet Jack Pinouts.....	C-63
C-43	IPR*4 10/100 BT Card Ethernet Jack Pinouts	C-64

List of Tables

Chapter 1

System Reference Guide

What's New

Changes in this document from the previous released version is marked with a 'change bar' as seen below and in the left-hand margin.

New or changed in this document from the previous version are:

Version A2 of this document puts the OCU-DP section back with Data cards.

Section 5.11.1 on page 5-38 - AMT feature enhancement.

Section 7.4.1 on page 7-26 - AMT related SYSLOG events.

Section 9.2.1.1 on page 9-2 WAN default strapping clarification.

Chapter 21: RIP default time outs for IPR*4 card.

1.1 Product Description

Release 7.2.3 is the latest host code release for the 7.x.y platform. All supported capabilities existing in the 5.x.y and 6.x.y series are available and supported in the 7.x.y series.

Release 7.x.y has made hardware changes to the CPU and Interface cards with the intent of providing a low-impact switching time when going between processors. This time is targeted to be less than 250 micro seconds, and is supported for several card types.

1.1.1 CPU Card Support

Host code 7.x.y operates on the 880770 CPU card and requires PRM-607xy or PRM-617xy Host Firmware. No other CPU Cards are supported.

1.1.2 Interface Cards Supported in Release

Host code 7.x.y is not compatible with Interface Cards 8922xx, 8923xx, or 8924xx series. The CPU-7 series requires the use of the interface cards without the NVRAM installed, which are new boards. These models are 893270, 893370 and 893470. No other Interface Cards are supported.

1.1.3 Low interruption Cards Supported in Release 7.x.y

As described, low-impact to service during a processor switch on CPU-7 hardware platform is meant to be less than 250 micro seconds for several card types. The cards tested, validated and updated to be low-interrupt are listed below in Table 1-1. Other cards may or may not experience a low-interruption rate, but for sake of this document it should be expected that all other cards will experience the same outage as existed in previous releases, namely about a 12-second interruption on a switch of the host processor. The supported card list is:

Table 1-1. Low impact Supported Card list

Server	Voice	Data	WAN
IPR*4	FXS	SRU	All
ADPCM	FXO	LD-SRU	
Analog Bridge	E&M	HSU	
MCC		OHSU 2-PORT	
		OHSU 4-PORT	

1.2 System Cards

1.2.1 Card Support

No support has been taken away for any card previously supported in the IMACS 600, 800 and 900 family. CPU-7 has not been validated with every available card in the IMACS portfolio, and therefore this document lists currently available cards only. Older cards should continue to work as previously in CPU-7, however these cards are not included in the reduced outage time upon a CPU switch of activity, and an outage should be expected on cards that do not appear in this document.

1.2.1.1 CPU XCON (880770)

The 880770 CPU XCON with Ethernet Port card supports complex applications requiring more than two WAN ports and the ability to cross-connect DS0s between WANs. The 880770 supports up to four WAN Cards for a total of eight T1 or E1 WAN ports and has a built-in

cross-connect module. A system that uses an 880770 CPU Card operates in “cross-connect” mode. Two Model 880770 CPUs can be installed in slots C1 and C2 to achieve CPU redundancy. The 880770 also supports 1xN WAN and Power Supply redundancy.

The CPU XCON Card with Ethernet port controls the Integrated Access System. It performs the following functions:

- Initializes the system upon power-up, and runs a self-test on all cards plugged into the chassis at that time.
- Polls all cards in the system every second to determine their operating status.
- Processes all incoming operator commands and displays the responses in a series of operator interface screens for each card in the system. The operator interface system (local VT-100 terminal, remote computer, or network management system) connects to the Interface card, which sends these commands to the CPU card for processing.
- Includes circuitry that allows you to cross-connect DS0 time slots between T1 and E1 lines connected to the system WAN cards. Refer to the DS0 time slot assignment operations.
- Includes a test pattern generator for T1 and E1 line test purposes.
- Performs primary-secondary CPU arbitration. In a system with redundant CPU cards, the two CPU cards communicate their status to each other. If the primary CPU card fails, the redundant card takes over and becomes the primary.
- PRM-60712 Enables Ethernet connection for remote management, configuration and downloading of host code via a 10baseT Ethernet port.
- PRM-61712 disables the 10baseT Ethernet port.

1.2.1.2 Voice Cards

This host code release supports the following voice cards:

- **E&M** **E&M 2W*8 (810860), E&M 4W*8 (811960),**
- **FXS** **FXS 2W*8-6 (812960)**
- **FXO** **FXO 2W*8-6 (813970)**



Note: Cards listed in italics have been Manufacturing Discontinued (MD).

1.2.1.3 Data Cards

This host code release supports the following data cards:

- **HSU** **HSU*2 530/35 (820260), HSU-T 530 (820360),
HSU 35 (821260), HSU-T 530/35 (821460)
HSU*4 530/v35 (821550),HSU*4 530 (821570),
HSU*4E 530/v35 (821660)**
- **OHSU** **OHSU 2-Port (823760)**
- **OHSU** **OHSU 4-Port (823870, 823875)**
- **SRU** **SRU 232*10 (822060), SRU-232*10 (822160)
SRU 232*10 (822061), SRU-232*10 (822161)
LD SRU*10 (8225)**
- **OCU-DP** **OCU-DP 5 (824160), OCU-DP 10 (824660), OCU-DP (8249)**
- **DS0-DP** **DS0-DP 4 (825460)**



Note: Cards listed in italics have been Manufacturing Discontinued (MD).

1.2.1.4 Server Cards

This host code release supports the following server cards:

- **ADPCM** **ADPCM 64 (887170)**
- **MCC** **ACS-MCC (881360)**
- **IPR*4** **IPR*4 (883270)**
- **BRIDGE** **Analog Bridge (885070)**



Note: Cards listed in italics have been Manufacturing Discontinued (MD).

1.2.1.5 Alarm Cards

This host code release supports the following alarm cards:

- **ALR** **ALR 4+4 (840160)**

1.3 Customer Service and Ordering Information

1.3.1 Technical support

If you require assistance with the installation or operation of your product, or if you want to return a product for repair under warranty, contact Zhone customer service. The contact information is as follows:

E-mail	support@zhone.com
Telephone (North America)	877-ZHONE20
Telephone (International)	510-777-7133
Internet	www.zhone.com/support

If you purchased the product from an authorized dealer, distributor, Value Added Reseller (VAR), or third party, contact that supplier for technical assistance and warranty support.

Chapter 2

System Installation

2.1 Introduction

This chapter provides instructions for unpacking and installing the Integrated Access System chassis and plug-in cards at the user site. It also includes other information you will need to properly install the system and refers you to other chapters for additional card-level information.

The system can operate on either AC or DC power when equipped with the proper power supply. Refer to the system specifications section in this manual regarding electrical and environmental requirements.

2.2 User-Set Switches and Jumpers

Several plug-in cards of the Integrated Access System contain on-board switches and/or jumpers. Some cards also require you to install sub-modules for proper operation. You must prepare these cards before inserting them into the chassis.

Refer to Section A.5.2 on page A-17 for a list of cards and associated strap settings.

2.3 Chassis Installation

2.3.1 Unpacking the Chassis and Cards

The Integrated Access System chassis and cards are packed separately. When you receive your system, unpack the boxes and check the contents for damage. If anything is damaged, contact the shipping carrier to file a claim. The carrier representative will also tell you how to submit a claim, where to send the unit, and give you any special instructions you may need.

Pack the damaged item in its original packing materials and send it by prepaid freight to the address you received. If the original packing materials are unavailable, pack the unit in a sturdy box and surround it with shock-absorbing material.

2.3.2 Pre-Installation Tips

2.3.2.1 Installation Checklist

Install your Integrated Access System in the following sequence:

1. Choose a suitable location for the system, as described in this chapter.
2. Unpack and inspect the equipment for damage.
3. Mount the chassis on the desired surface (rack, tabletop, or wall).
4. Install the chassis ground connections.
5. Set the chassis jumper for U.S. or European operating voltage compliance.
6. Remove the power supply covers from the chassis.
7. Install the AC or DC power supplies.
8. Install an AC-to-DC converter (if necessary).
9. Install a ringing generator (if necessary).
10. Verify the voltage ratings of all power supplies in the chassis.
11. Verify the fuse ratings of the source power supply.
12. Install a CPU card.
13. Install the Interface card.
14. Install the WAN cards.
15. Install server cards, as required.
16. Install the user (voice, data, and alarm) cards, as required.
17. Install the power supply covers on the chassis.
18. Apply power to the system and verify the power LED states.

After successfully installing the system, configure the system for operation as follows:

1. Connect a VT100-compatible terminal to the Interface card.
2. Log into the system, then register.
3. Set the Alarm Filters.
4. Configure the CPU card.
5. Configure the Interface card.
6. Configure the WAN cards.
7. Configure all other cards.

2.3.3 Choosing a Location for Your System

The Integrated Access System requires a reasonably dust-free, static-free operating environment, such as a computer room. Adequate ventilation is also required at the site. Do not install the chassis in direct sunlight, which may increase the system's operating temperature and affect its operation.

Most of the system plug-in cards have highly sensitive components that could be damaged by static electricity. Whenever you handle any system cards, be sure to observe local electrostatic discharge (ESD) precautions.

The mounting brackets supplied with the chassis are needed for tabletop installation. The top and bottom of each chassis also must be clear of objects to ensure proper air flow through the chassis.

The system chassis can be installed on an 19-inch or 23-inch equipment rack, attached to a wall, or placed on a tabletop or other level surface. First though, make sure the desired surface can support the weight of a fully equipped chassis.

The system specifications section in this manual lists the maximum power consumption of each system card. Use this table to calculate the total system power consumption.

The system specifications section in this manual also lists some typical current measurements for each card at all DC operating voltages.

Be sure to locate the system near all external equipment to which you will connect it. Cable lengths and physical/electrical characteristics are critical to system operation, especially for data signal interfaces. Generally, higher data rates require shorter cables than lower data rates.

Also, you must use T1-grade or E1-grade cables for all system connections to those networks. For best results, use the cables supplied by your supplier when connecting your system to the associated external facilities. For more information on system cabling, call your supplier.

2.3.3.1 Rack Installation Tips

When installing the chassis in a rack, allow at least 2 inches (5.1 cm) of space between the chassis and the equipment above and below it for proper ventilation. Use the mounting brackets and attachment hardware furnished with the chassis for this purpose, as outlined in the next section. If you use other mounting hardware, you may damage the chassis or circuit boards installed in it.

Also route all cables to their destinations through conduits to enhance electromagnetic compatibility (EMC) performance and facilitate future system troubleshooting. When routing cables, be sure not to obstruct any chassis vents.

2.3.3.2 Wall-Mount Installation Tips

To mount the chassis on a wall, first obtain a piece of standard, marine-grade plywood (3/8 inch diameter, typical) and bolt it firmly to the desired mounting surface. This board must be long and wide enough to cover the entire chassis length and height. The surface must be able to support the total weight of the system (chassis plus plug-in cards).

2.3.3.3 Tabletop Installation Tips

The chassis should be placed on a flat, smooth surface (e.g., a table) that is free of contaminants. This surface should be capable of supporting a fully equipped chassis. Be sure to allow enough clearance above and below the chassis for proper air circulation. You must use the metal brackets and feet furnished with the chassis for this purpose.

2.3.4 Installing the Chassis

2.3.4.1 Front-Loading Chassis with Power Supplies on Side

The front-loading chassis with power supplies on the side has eight holes on each side, as shown in Figure 2-1. These holes are for mounting in a standard 19-inch or 23-inch rack (48.2 or 58.4 cm). The holes labeled “T” on the bottom are for tabletop mounting.

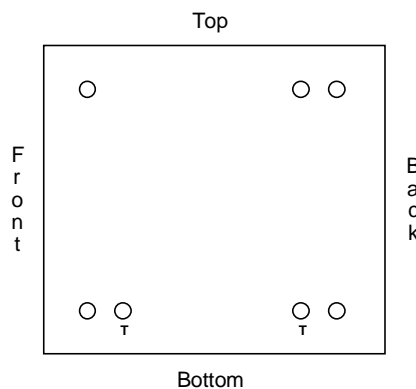

Figure 2-1. Mounting Holes for Front-Loading Chassis with Power Supplies on the Side

Figure 2-2 shows the mounting bracket holes. To mount the chassis in a rack, first attach the brackets to the sides of the chassis, using the four associated 10-32 x 1/4" screws. You can attach the brackets to either the front or rear of the chassis. Then, use the four 12-24 x 1/4" screws to mount the bracketed chassis on the rack.

The brackets are also reversible for mounting in 19-inch or 23-inch racks (48.2 or 58.4 cm). For a 19-inch rack, attach the long sides of the brackets to the chassis. For a 23-inch rack, attach the short sides of the brackets to the chassis.

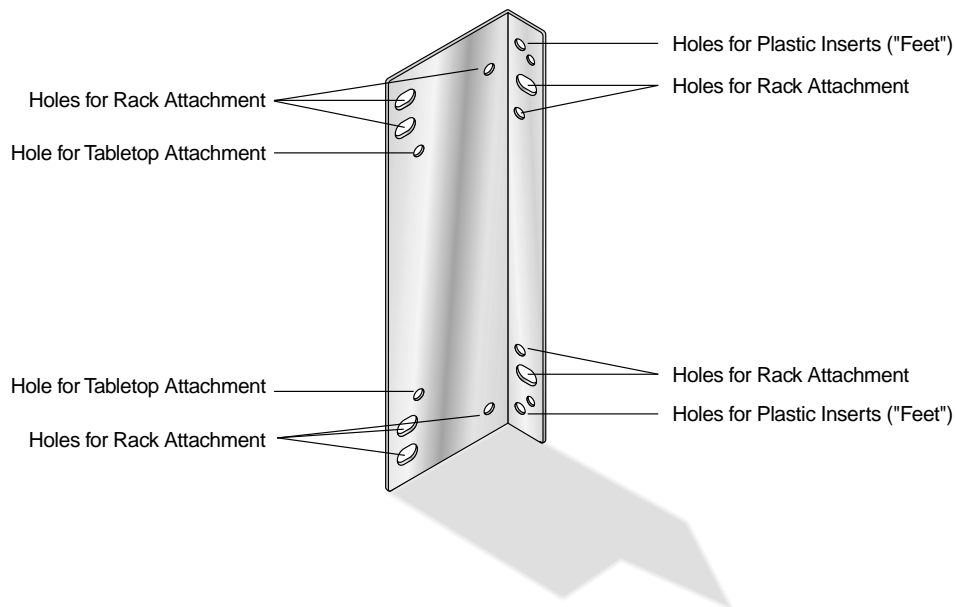

Figure 2-2. Mounting Bracket Holes

If you are placing the chassis on a tabletop or other flat surface, be sure to leave enough clearance for air circulation through the system. Make sure the chassis is accessible from the front, and that it has at least 3/4 inches (2 cm) of room above it. Attach the metal brackets to the chassis sides. Then, insert the plastic abrasion-protective "feet" in the holes near the ends of the bracket.

2.3.4.2 Front-Loading Chassis with Power Supplies on Top

The front-loading chassis with power supplies on top also has eight holes on the bottom of each side, as shown in Figure 2-3. Attach the mounting brackets of Figure 2-3 to these holes on each side of the chassis, in order to mount the chassis in a 19- or 23-inch rack. Or, attach the brackets to the two holes on the bottom of the chassis for mounting on a tabletop or other flat surface.

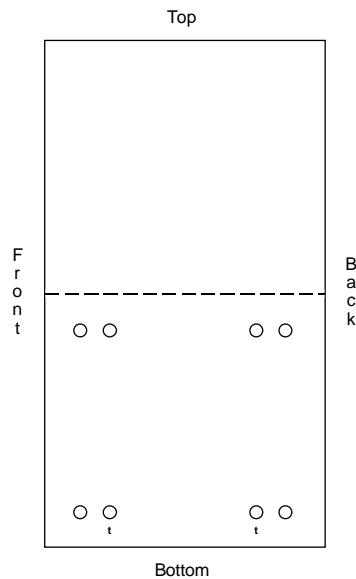

Figure 2-3. Mounting Holes for Front-Loading Chassis with Power Supplies on Top

2.3.4.3 Two-Sided Chassis

The two-sided chassis have 12 holes on each side, as shown in Figure 2-4. These holes facilitate mounting in a 19- or 23-inch rack (48.2 or 58.4 cm). You can attach the front, middle, or rear of this chassis to a rack, using the mounting brackets as previously shown for the front-loading chassis with power supplies on the side. To place a two-sided chassis on a tabletop, attach the mounting brackets to the two holes on the bottoms of the chassis sides.

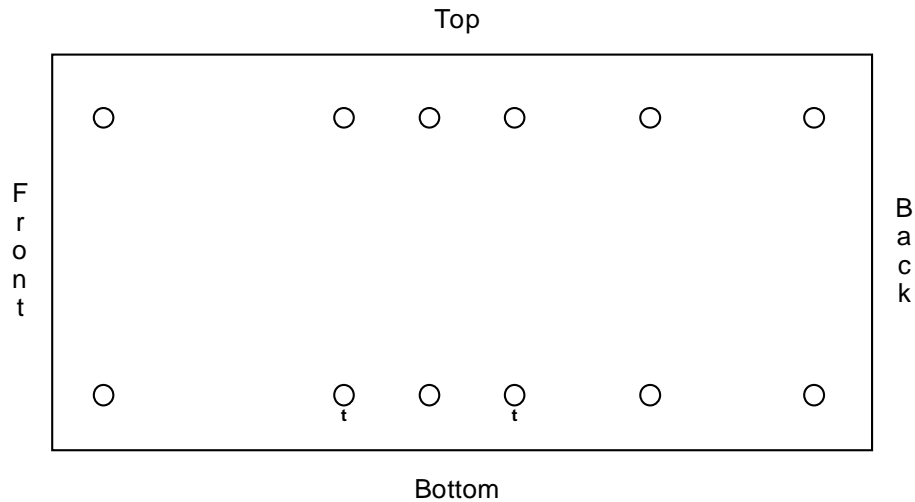

Figure 2-4. Two-Sided Chassis Mounting Holes

Be sure both the front and rear of the chassis are accessible for inserting and removing cards. The voice, data, and WAN cards, and the power cables, are attached to connectors at the rear of the chassis. Table 2-1 lists the minimum clearances required between the system chassis and the nearest objects.

Table 2-1. Minimum Two-Sided Chassis Clearances

Clearance	Front	Rear	Top	Bottom
Inches	10	15	3/4	2
Centimeters	25	38	2	5

2.4 Power Supplies and Ringing Generators

The power supply and ringing generators (8901, 8902, 8903, 8905, and 890620) system can consist of up to two power supplies, two AC-to-DC converters, and up to five ringing generators. External -48V talk battery and ringing generators may be used instead of the internal units. Use the following guidelines to determine your power supply and ringing generator requirements.

2.4.1 System Power (Redundancy)

The system always requires a 120/240 VAC, -48 VDC, or 24 VDC Power Supply. For backup, you may add a second identical power supply.



Note: Even though the 24 VDC supply has specifications listed as positive throughout this manual, it can be used with a negative voltage (-24V). Because of the extremely small number of applications that would require -24V, it is not covered in this manual.

2.4.2 -48V Talk Battery Requirements

Talk battery is required whenever you have voice user cards in the system, unless (a) all of those are E&M cards and are used in the Transmission-Only mode, or (b) Type 1 E&M signaling is used. A -48 VDC power source is also required for use with the ALR 4+4 or ALR 4+3PF External Alarm Cards, OCU-DP cards, and to provide sealing current for BRI cards. The -48 VDC talk battery can be provided from an external source, or by using a 115 VAC to -48 VDC Converter. This unit is only available for 115 VAC sources. A similar AC-to-DC Converter is also available for use with either 115 or 220 VAC.

2.4.3 Setting the U.S./European Configuration Jumper

Before inserting any cards into the chassis, set its JP1 jumper for either the U.S. or European configuration. This jumper is shown in Figure 2-5; it is on the resource card backplane and is accessible from the chassis front. The default jumper setting is **US** (for systems in the U.S. and Canada). To change the chassis electrical configuration for European compliance (**EUR**), move the jumper to pins 2 and 3.



Figure 2-5. JP1 Jumper Settings

Also be sure to set the jumper on the system resource cards and external alarm cards to agree with the above setting for the chassis. Refer to the associated chapters in this guide for information on those card jumpers.

2.4.4 Installing the System Power Cards

Next, install power supplies, AC-to-DC power converters and ringing generators into the system chassis as described in this section. However, do not apply power to the system until you finish installing these cards, AND after making the power and ground connections to the chassis as described in the next section of this chapter.



CAUTION!

Failure to follow the procedures mentioned above will result in damaging the boards.

2.4.5 Talk Battery Supply Fuses

The talk battery fuse for the DC Power Supply is in a removable cartridge next to the DC input socket on the front or rear panel (depending on which chassis you may have). They are only for external power supplied to the V_N leads and are not to the power supplied by the 8906 converter. The power supply should have a 5Amp fuse on it. Refer to the system specifications section in this manual.

2.4.6 AC Power Supply and DC Power Supply Fuses

The AC power supply and DC Power Supply fuses are already built in to the supplies. When unpacking the unit a power cord will be in the box. The AC inlet connector is located in the front or rear of the chassis. Refer to the system specifications section in this manual.

2.4.7 Installing AC or DC Power Supplies

To install the AC or DC power supply in a chassis, first remove the panel covering the front power slot. Then, hold the power supply by its metal handle and align the printed circuit board (PCB) edges with the rail guides of either power supply slot. Push the unit in until it is firmly seated in the backplane connector, and replace the panel cover. For redundant power supplies, also insert a second AC or DC power supply into the adjacent slot.

When the AC or DC power supply is installed and power is applied, the green LED on the front panel of the power supply should light. A problem exists if this LED does not light. Verify that the power supply is properly seated in the connector. Also check the external power source and connections to the power supply. If the power supply is properly seated, and the external power source and power connections are operational, replace the power supply. Replace the panel cover.

2.4.8 Installing the -48V Converters (8903/8905/8908)

To install a -48V Converter in a chassis, proceed as follows. Refer to the system specification section in this manual for the -48V Converters. Figure 2-6 shows the location of the fuse on the converter board.

1. For a two-sided chassis, remove the panel covering the rear power slots. You may insert or remove the module in any of the five rear slots while power is on or off. For a front-loading chassis, remove the panel covering the front power slots. You may insert or remove the panel while power is on or off.
2. Hold the converter by its metal handle and align the PCB edges with the slot rail guides in the chassis. Gently push the converter in until it is firmly seated in the backplane connector.
3. When the power converter is installed and power is applied, the green LED on the front panel of the converter should light. A problem exists if this LED does not light. Verify that the power converter is properly seated in the connector. If so, also check the external power source and connection to the power supply. If the power converter is properly seated, and the external power source and power connections are operational, replace the converter.
4. Replace the panel cover.



Note: *The 8908 unit can only be installed in the 891930 chassis.*



Note: There are two different types of 100W -48V Converters; one with full range and one with limited. 8903 - 120V only, 8905 - 120/240V. Fuses are Slo-Blo type 3A/250V for 8903 and 2.5A/250V for 8905.

Table 2-B-10. -48V Converter Specifications

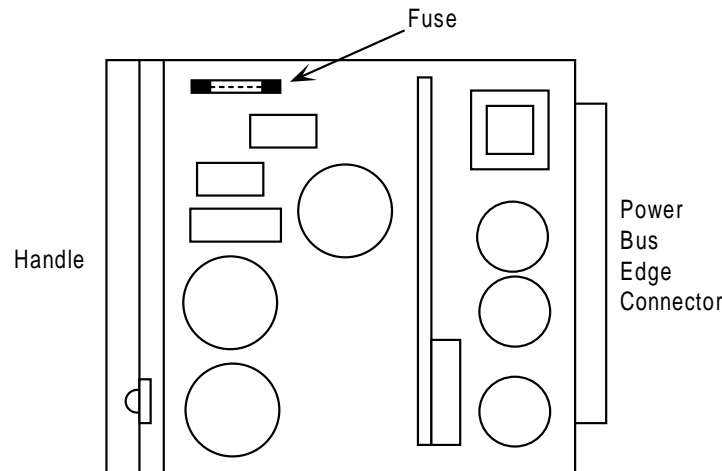

Figure 2-6. -48V Converter Fuse

2.5 Ringing Generators

The ringing generator provides a ringing voltage of 105 VAC (nominal) at 20 Hz for simultaneously ringing 11 voice ports. If more than one ringing generator is required in the same chassis, they must have the same model number. **Ringing Generators cannot be mixed with 8906 and 890620 in a single chassis.**

Make sure the system uses a -48V power source before installing any ringing generators. This can be achieved using either the 890220 -48Vdc supplies or using the 8905 48V dc convertor module in conjunction with the 8901 AC supplies. You can install up to four ringing generators in a two-sided chassis, depending on the availability of its slots. The front-loading chassis 600 can have only one ringing generator each. The front-loading chassis 900 can have two ringing generators each.

When two or more ringing generators are used, the outputs of all ringing generators are linked together by OR circuits on the ringing bus. One generator must be jumpered as the MASTER and the others must be jumpered as SLAVES. The master ringing generator then synchronizes the ringing signals on the ringing bus. Refer to the system specification section in this manual for the ringing generators.

2.5.1 Ringing Generators (8906/890620)

Ringing generators are needed if the system has FXS or FXS-C cards, or if it has FXO or FXO-C cards with ports connected to Manual Ringdown (MRD) circuits. The 20 Hz ringing voltage may be provided either by an external source or with a Ringing Generator, which requires the presence of -48 VDC in the system. **Ringing Generators cannot be used in conjunction with external ringing sources.**

The ringing generators provide a ringing voltage of 105 VAC at 20 Hz for 11 simultaneously ringing voice ports. Since most systems will not have that much activity, a single Ringing Generator might provide all of the power necessary to run the system. In a group where incoming calls are at a minimum, 30 to 50 stations could share the same ringing generator. Small groups with heavy incoming call volumes might require two or more Ringing Generators. This condition should alert you to the need for additional equipment.



CAUTION!

Do not mix 8906 and 890620 Ringing Generators in the same chassis.

The compatibility of power sources used together are summarized in the system specification section in this manual.

2.5.2 Installing the 105V Ringing Generator (8906/890620)

To install a 105V Ringing Generator, proceed as follows:

1. **Make sure power is turned off before inserting the ringing generator (8906 only).** The 890620 may be installed with power applied (“Hot swapping”). The 890620 ring generator has improved operating efficiency resulting in lower operating temperatures which promote a longer life expectancy and support of more analog voice ports per ring generator. It also provides inrush current control during start-up allowing for hot insertion (plugging) without disrupting the Integrated Access System power supply busses.
2. Make sure jumper W201 is installed if this is the only ringing generator in the unit, if it is the MASTER ringing generator, refer to Figure 2-7. If this is a SLAVE ringing generator, cut jumper W201 with wire cutters.
3. For a two-sided chassis, remove the panel covering the rear power slots. You can insert the generator into any of the five rear slots. For the front-loading chassis with power supplies on top, remove the panel covering the front power slots, and insert the module in any of the five slots. For the front-loading chassis with power supplies on the side, insert the ringing generator only into slot R1.

4. Hold the unit by its metal handle and align the PCB edges with the slot rail guides in the power supply backplane. Gently push the unit in until it is firmly seated in the backplane connector.
5. If the power supply is installed and power is on, the LED on the front panel of the ringing generator should illuminate green. A problem exists if the LED is not illuminated. Verify that the MASTER/SLAVE settings are correct, and that the unit is firmly seated in the connector. If so, replace the ringing generator (it is faulty).



Note: In previous releases the ringing generator LED flickered, indicating a functioning unit.

6. Replace the panel cover.

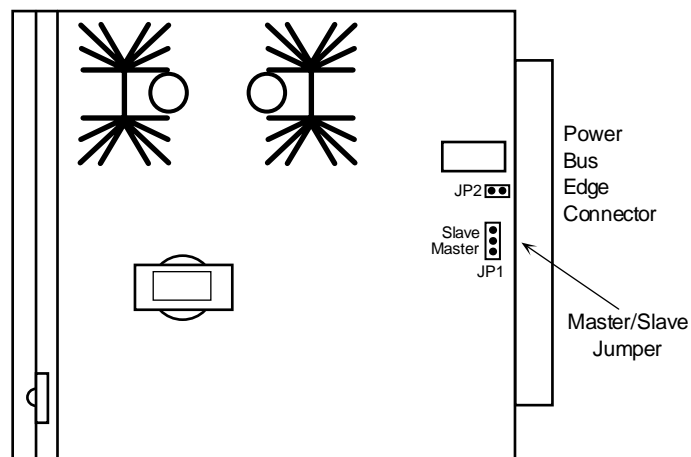

Figure 2-7. 105V Ringing Generator Jumper Setting



Note: JP2 is available only on 8906 and must be in place on the ring generator.

2.6 System Power and Ground Connections

After installing the system power cards into the chassis, make the power and ground connections to the chassis as described in this section. Each chassis has a terminal strip for the DC voltage, ringing generator, and ground connections.

2.6.1 Front-Loading Chassis with Power Supplies on the Side (891630)

Figure 2-8 and Figure 2-9 shows the AC and DC power and ground connections to a front-loading chassis with power supplies on the side.

Connect the grounds and DC power signals to this terminal block by inserting the wires (max. 14 gauge wire) in the proper slots, then tightening the screws adjacent to the slots to secure the connections. For safety reasons, no more than one-eighth inch (0.125") of each connecting wire should be exposed. **No uninsulated wire should be visible from the terminal block.**

The power terminal block also provides dual power connections at V_A and V_B where redundant power feeds are required. The V_A pins feed power supply slot S1, and the V_B pins feed power supply slot S2.

In addition, you can connect the V_N pins of the block to an external -48V source for talk battery to voice cards (FXS and FXO), signal battery to E&M cards, and sealing current to OCUDP and ISDN cards. The **COM** (common) pin is the systems digital ground connection, and the **RGR** (ringer) pin is for connecting an external 20 Hz ring generator input to the chassis. The ringing voltage bias is selected by a connection to V_{N+} or V_{N-} .

When operating from a DC source, a protective earth ground must be connected to the "Protective Earth/Chassis Ground" (\oplus) terminal block location. When operating from an AC source, this connection is made through the power cords "third wire" ground.

If your system will be connected to voice circuits that use E&M or FX ground-start signaling, connect the chassis ground terminal to the same chassis ground used by the external PBX or other system. Tying the chassis grounds together will ensure proper signaling operation and transmission between the two ends of each circuit.



Note: If -48 VDC is applied to V_A or V_B , DO NOT connect external power to V_N .

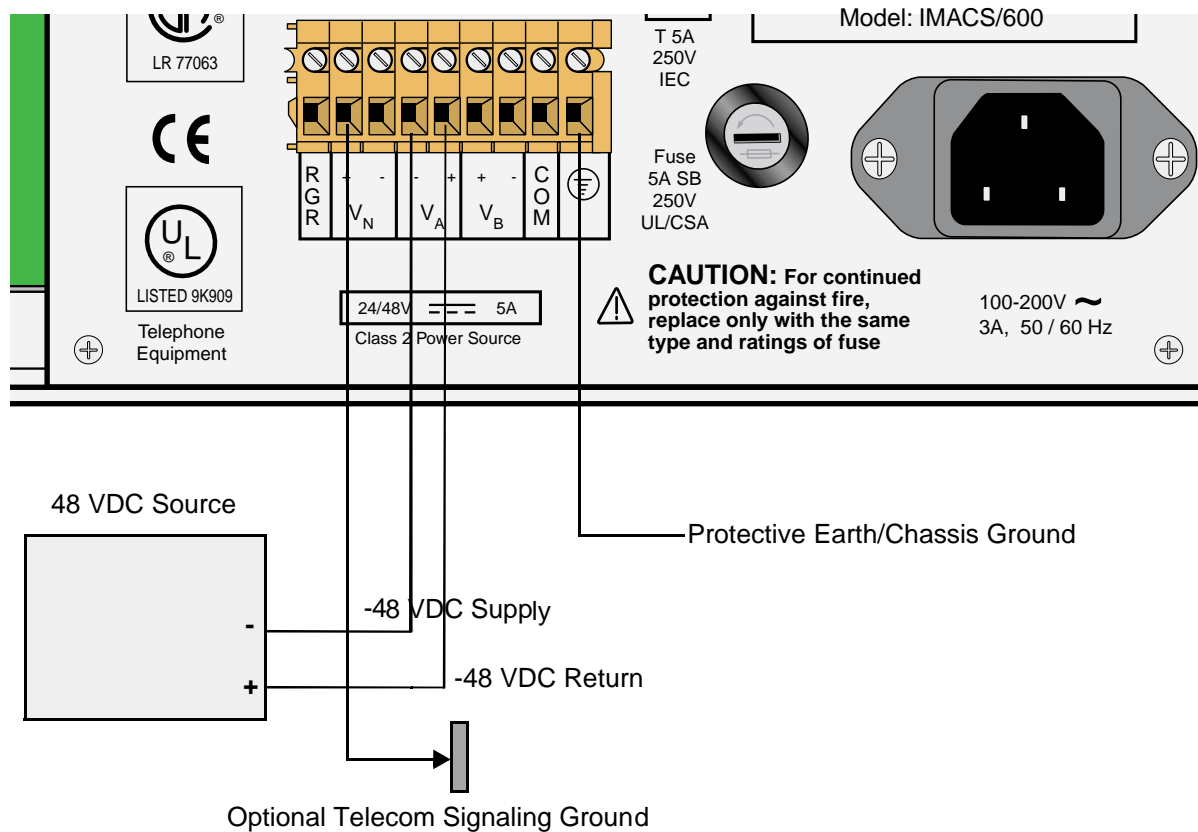

Figure 2-8. Front-Loading Chassis Power Supplies on the Side in a DC Environment



Note: *Optional Telecom Signaling Ground* - It may be required when the -48 VDC source output is not referenced ground or when the system is AC powered. It is only needed for the proper operation of the Telecom Ground Start and E&M signaling circuits.

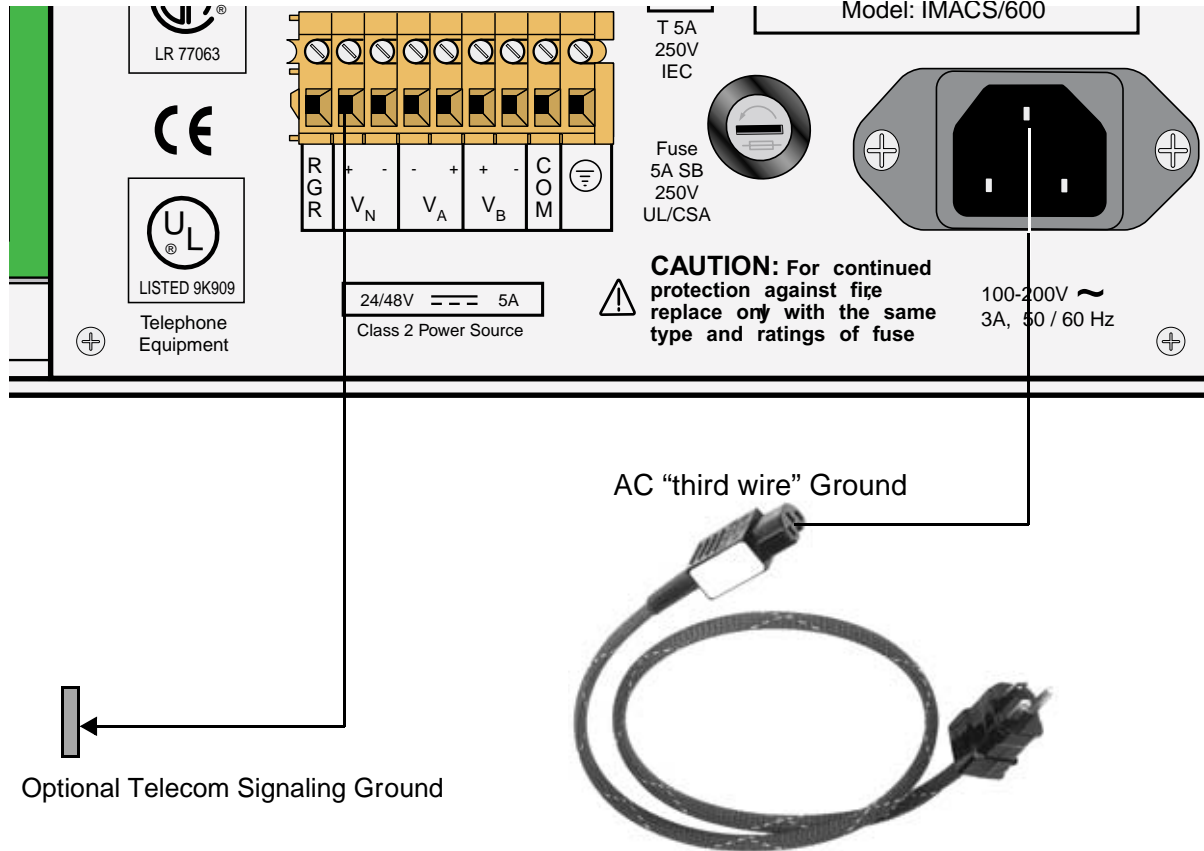

Figure 2-9. Front-Loading Chassis Power Supplies on the Side in a AC Environment



Note: The AC "third wire" ground is connected to the system's protective earth lug, located inside the system chassis.

2.6.2 Two-Sided Chassis (891830)

Figure 2-10 shows the DC power connector block on the two-sided chassis with power supplies on the side. Figure 2-11 shows the AC power connector block for the same chassis.

Connect the grounds and DC power signals to this block by inserting the wires in the proper slots, then tightening the screws adjacent to the slots to secure the connections. For safety reasons, no more than one-eighth inch (0.125") of each connecting wire should be exposed. **No uninsulated wire should be visible from the power connector block.**

The power connector block also provides dual power connections at V_A and V_B where redundant power feeds are required. The V_A pins feed power supply slot F1, and the V_B pins feed power supply slot F2.

In addition, you can connect the V_N pins of the block to an external -48V source for talk battery to voice cards (FXS and FXO), signal battery to E&M cards, and sealing current to OCUDP and ISDN cards. The **COM** (common) pin is for a signal ground connection, and the **RGR** (ringer) pin is for an external 20 Hz ringing input to the chassis. The ringing voltage bias is selected by a connection to V_{N+} or V_{N-} .

When operating from a DC source, a protective earth ground must be connected to the "Protective Earth/Chassis Ground" (\oplus) terminal block location. When operating from an AC source, this connection is made through the power cords "third wire" ground.

If your system will be connected to voice circuits that use E&M or FX ground-start signaling, connect the chassis ground terminal to the same chassis ground used by the external PBX or other system. Tying the chassis grounds together will ensure proper signaling operation and transmission between the two ends of each circuit.



Note: If -48 VDC is applied to V_A or V_B , DO NOT connect external power to V_N .

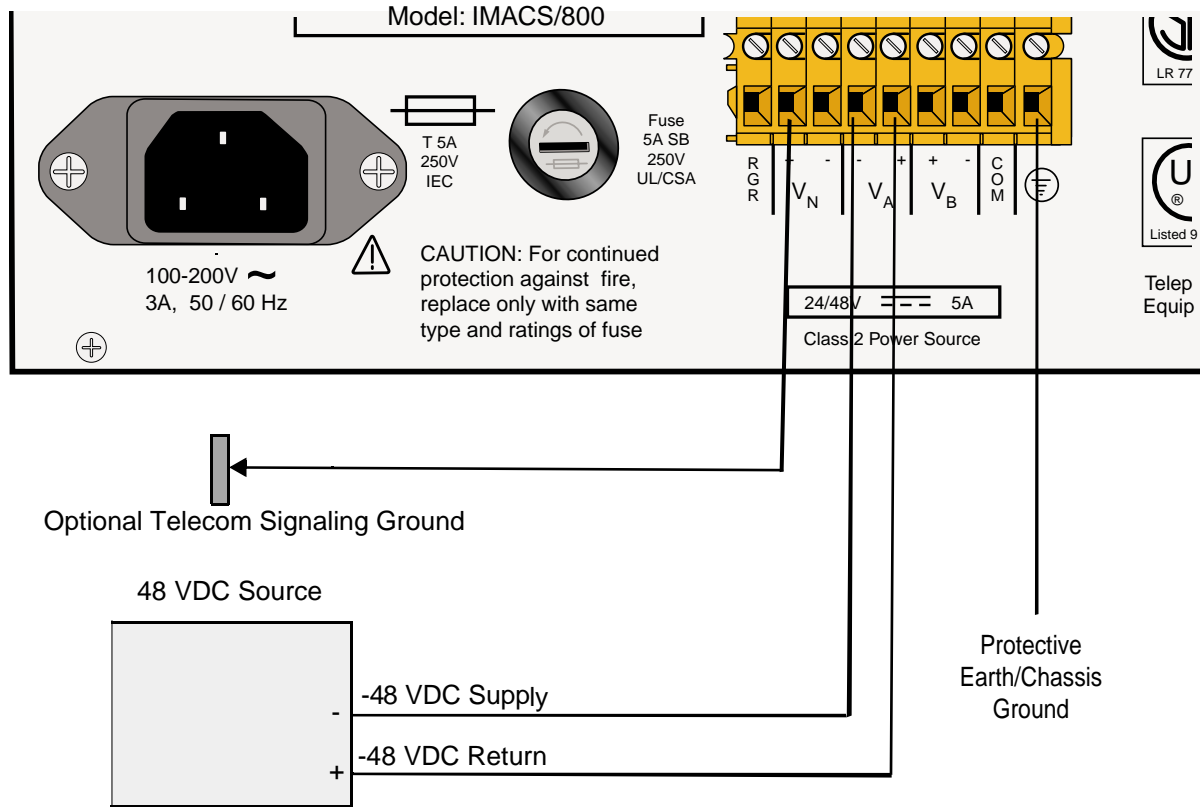

Figure 2-10. Two-Sided Chassis Power Supplies on the Side in a DC Environment



Note: *Optional Telecom Signaling Ground - It may be required when the -48 VDC source output is not referenced ground or when the system is AC powered. It is only needed for the proper operation of the Telecom Ground Start and E&M signaling circuits.*

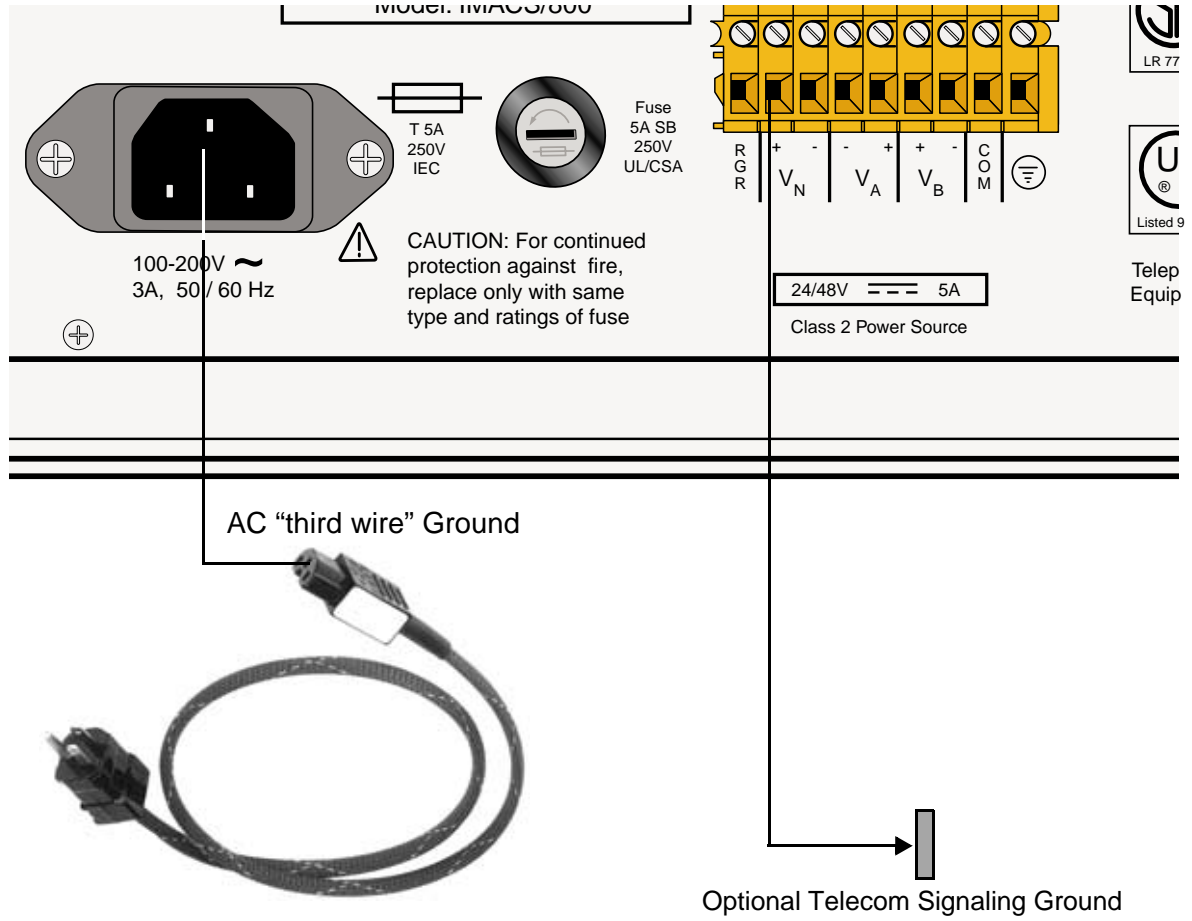

Figure 2-11. Two-Sided Chassis Power Supplies on the Side in a AC Environment



Note: The AC "third wire" ground is connected to the system's protective earth lug, located inside the system chassis.

2.6.3 Power Enhanced Chassis with Power Supplies in Front (891930)

Figure 2-12 shows the terminal block on the front-loading chassis with power enhancement on top. Although the terminal block is oriented vertically on this chassis, it provides an improved external terminal block that requires additional jumpers to provide power to user cards that apply voltage to the CPE device.

The V_{NA} and V_{NB} leads were added to provide an interface for a separate, redundant or non-redundant power source to the system. The V_{NA} and V_{NB} leads are no longer referenced to the V_A and V_B leads respectively. As a result this condition if you are running a DC system with -48VDC connected to the V_A (F1 Power Supply) or V_B (F2 Power Supply) leads, you will not have any battery applied to any of the user cards that require the -48VDC towards the CPE equipment. There must be a separate source applied to the V_{NA} or V_{NB} leads to provide the -48VDC source to the connecting CPE equipment. If a second source is not available you may install a jumper from the V_A or V_B source leads using 16 gauge wire. The V_A or V_B source feed must also be 16 gauge wire if a jumper between leads is required. In addition, you can connect the V_N pins of the block to an external -48V source for talk battery to voice cards (FXS and FXO), signal battery to E&M cards, and sealing current to OCUDP and ISDN cards.

The telecommunications voice signaling ground is referenced ground connection to the V_{NA+} side or V_{NB+} side of the -48VDC power system. Both of these feeds are referenced to the same place on the backplane. This reference ground can occur at the Integrated Access System power connection strip or at the -48VDC power source, which ever is more effective if having multiple connections back to a ground source is not desirable. The wire connection between the V_{NA+} , V_{NB+} , V_{A+} , or the V_{B+} terminals, and a referenced ground is required to eliminate ground isolation between connection devices. **If this ground connection is not maintained, and one side of the connection equipment is not referenced to an earth ground then a floating ground condition can occur causing the voice circuits and the voice signaling to react erratically when either end of the connecting equipment tries to start the circuit.**

When running the system in an AC environment with an AC/DC converter installed in the chassis, the V_{NA+} or V_{NB+} must have the same ground reference as the connecting equipment so as not to produce a floating ground potential as discussed earlier.

Sites using only loop start telecommunication circuits (no ground start or E&M signaling) can operate properly without the Telecom Signaling Ground.

When grounding the system, use 14 gauge solid wire for a single connection to the terminal block connector. When there is no way to provide multiple separate ground feeds use 16 gauge solid wire to connect from one terminal block pin to another terminal block pin with a ground feed on one of the terminal block pins that are looped together. If you use different gauge wire on the feed terminal block pin and the looped terminal block pins the connection may not have the proper integrity due to the larger size wire impeding a solid connection to the smaller wire.

In all previous versions, the chassis and ground was either tied together via the terminal block connector or when the logic cards were inserted and secured with the panel screws. This caused the ground scheme of the system to be automatically tied together via the logic card.

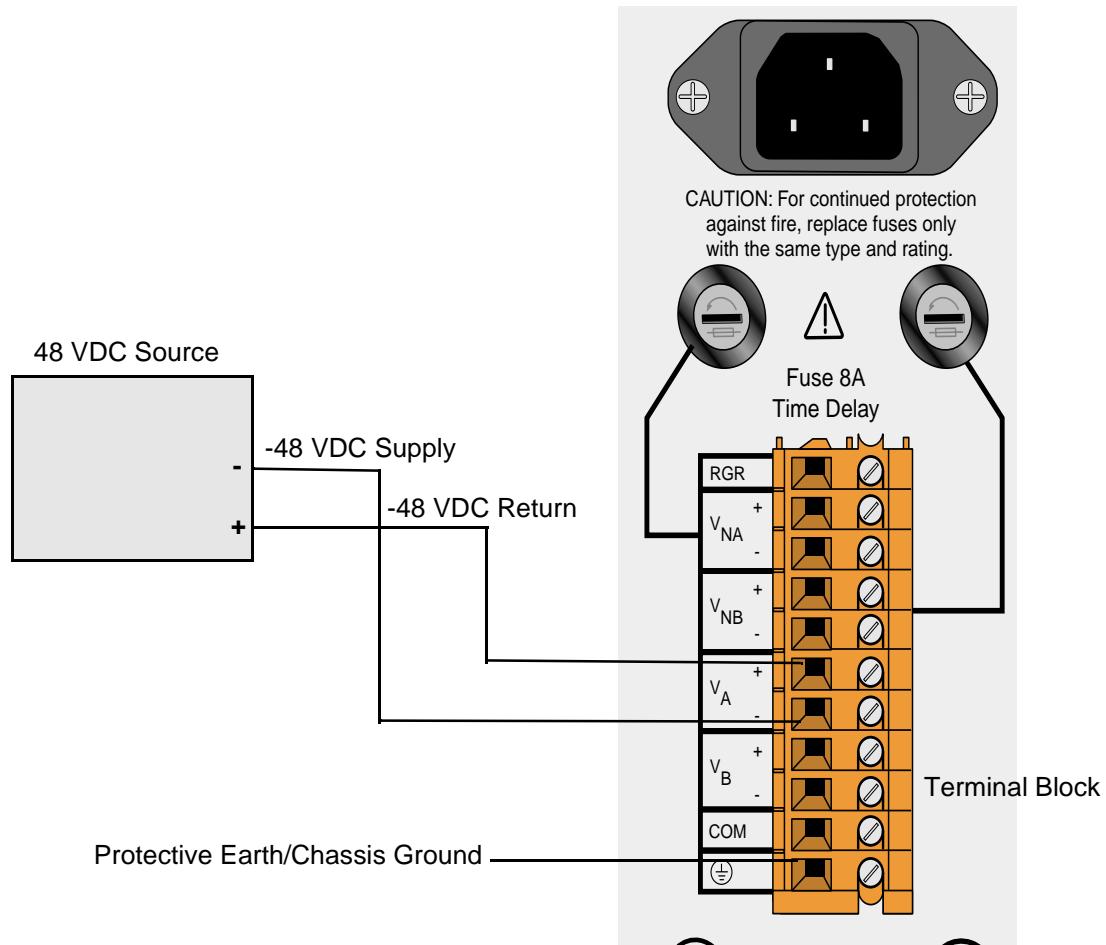

Figure 2-12. Enhanced Chassis Power Supplies on Top DC Environment - one Power Source



Note: The diagram above only depicts one DC power source which would support the F1 power supply. If a redundant power configuration is desired, then a second power source would be applied to the V_B (+ & -) leads. A separate feed is not required to the V_{NB} (+ & -) leads unless a redundant feed is preferred.

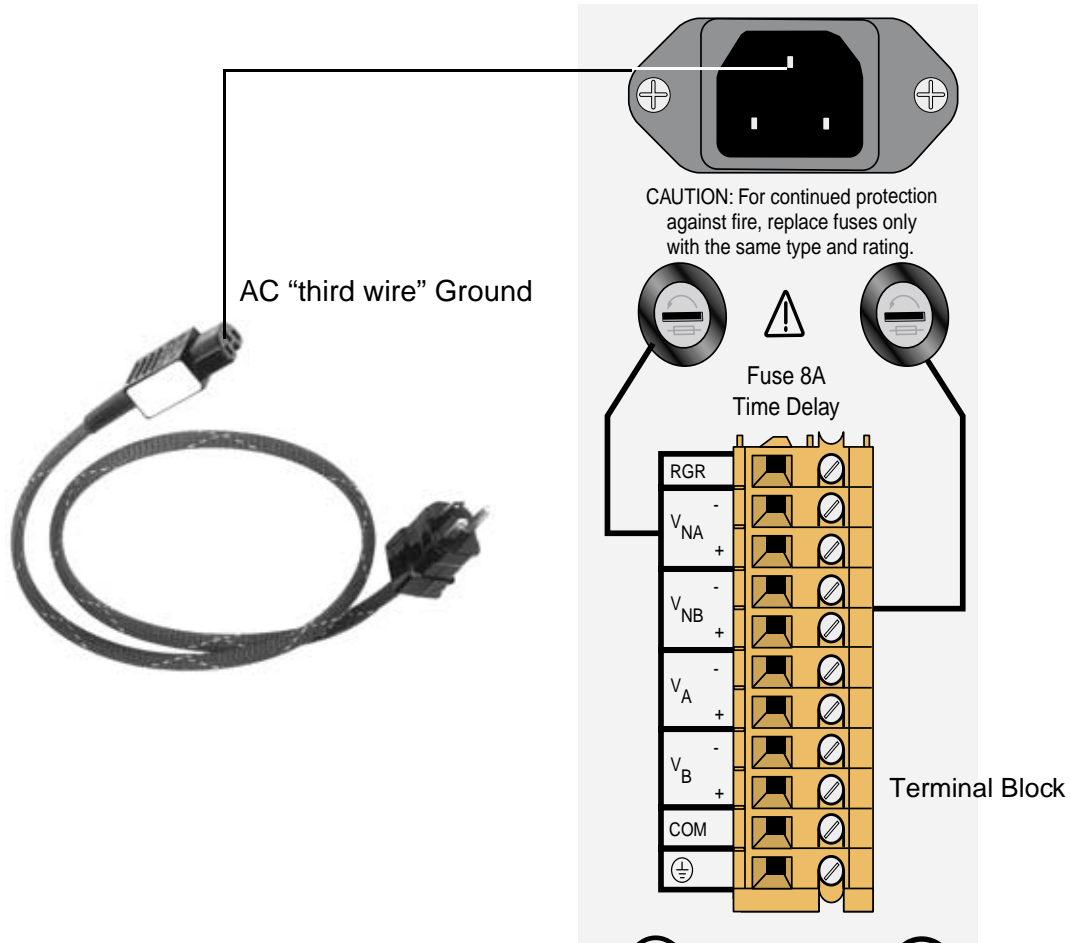

Figure 2-13. Enhanced Chassis Power Supplies on Top in an AC Environment with an -48VDC AC/DC Converter for Voice or Data Applications

2.7 Special Grounding Considerations

For systems that are operating in a ground-referenced mode (such as FXS Ground Start, E&M, FXO and Analog DSM), the chassis must be connected to Earth ground, and the VN+ screw terminal must be jumpered to the chassis ground screw terminal or to an Earth ground that the connecting equipment (PBX or Central Office) is using as a reference. The chassis ground screw terminal is normally connected to the earth ground directly via the rack that the device is connected to.

Indications that you may need to implement the grounding covered in this section are signaling issues with Voice Cards (E&M, FXS, FXO or Analog DSM). Should you have such situations, you should connect the battery ground that the voice channels are using to a ground reference that is being used by the connecting equipment. A grounding path differential as little as 5 Ohms between the two ground points on the same chassis can provide an induced ground loop current path.



Note: *Improper grounding may cause a difference in electrical potential between the chassis and the terminal equipment, which could damage the IMACS cards, the CPE terminal equipment, or both. Please see your system administrator for the proper system grounding scheme for your network.*

Sites using only loop start telecommunications circuits (no ground start or E&M) can operate properly without following this Special Grounding section. However, most data communication circuits, especially those that use unbalanced ground reference, benefit from using these recommendations.

When grounding the system, you may use 14 gauge solid wire for the single connection to the Terminal Bus (TB) connector. When there is no way to provide multiple separate ground feeds you may use 16 gauge solid wire to loop connect from one TB pin to another TB pin with an outbound ground feed on one of the TB pins that is jumpered. If you use different gauge wire size wires for the outbound ground feed TB pin and the looped connected TB pins, the multi-connected TB pin may not securely clamp down both wire terminations due to the larger size wire.

Each IMACS chassis (600, 800 and 900) has three separate grounding path connections:

- 1) Chassis/Frame Grounding \oplus
- 2) Common system ground for data communications circuits (COM)
- 3) Return ground for analog signaling circuits (V_{N+})



Note: *The latest hardware revision of the IMACS 800 chassis (891830) has an optional chassis/frame grounding point on the lower back side of the chassis. A mounting bracket hole, 10-32 x 1/4" screw size, has an unpainted 3/4" diameter surface (unpainted) allowing for a #6 AWG log connection.*

The power connector strip on an IMACS chassis consists of the following connections (from left to right for *front and rear loading chassis*, and from top to bottom for *front loading chassis with the power supplies on top*. Refer to Figure 2-14 on page 2-25.

- 1) RGR for connection to an optional, external ringer generator PSU.
- 2) V_{N+} for the -48VDC Return lead to an external DC power source for voice only.
- 3) V_{N-} for the -48VDC Power lead to an external DC power source for voice only.
- 4) V_{A-} for the -48VDC Power lead to an external DC power source for S1 P/S.
- 5) V_{A+} for the -48VDC Return lead to an external DC power source for S1 P/S.
- 6) V_{B+} for the -48VDC Return lead to an external DC power source for S2 P/S.
- 7) V_{B-} for the -48VDC Power lead to an external DC power source for S2 P/S.
- 8) COM is for data communications and related digital circuit reference grounding
- 9) Chassis/Frame grounding, also called earth/safety ground.

2.7.1 For -48VDC Powered Systems

The telecommunications voice signaling ground is a referenced ground connection to the V_{N+} side of the -48VDC power system. This referenced ground connection could also be the connection to the return side of the power feed on the V_{A+} or V_{B+} connector when the system is configured to run on DC power. This reference ground can occur at the IMACS power connection strip or at the -48VDC power source, whichever is more effective so as to not have multiple connections back to the grounding source. The wire connection between the V_{N+} , V_{A+} or the V_{B+} terminal is a referenced ground used to produce a ground potential that must be maintained between connecting devices. If this ground potential is not maintained, and one side of the connecting equipment is not referenced to an earth ground, then a floating ground condition could occur causing voice circuits and voice signaling to react erratically when either end of the connecting equipment tries to start the circuit.

Figure 2-14 illustrates the different connector types available on the IMACS shelves.

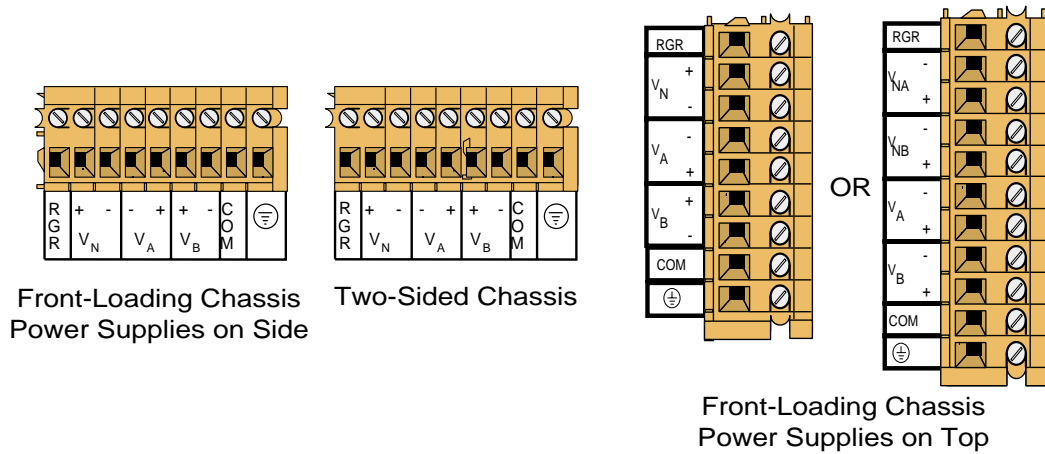

Figure 2-14. Terminal Connector Types

Making the connections to ground for ground-referenced circuits are covered in the next few illustrations. In all cases, +VN is connected either to the chassis ground, or to frame or earth ground. Figure 2-15 and Figure 2-16 display the possible ground options for the terminal strips shown above in Figure 2-14. One of the methods should be employed, but not both.

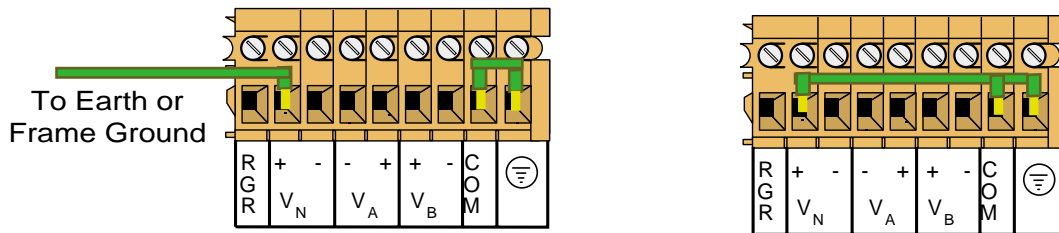

Figure 2-15. Two-Sided or Front-Loading Supplies on Side Ground Strap Methods

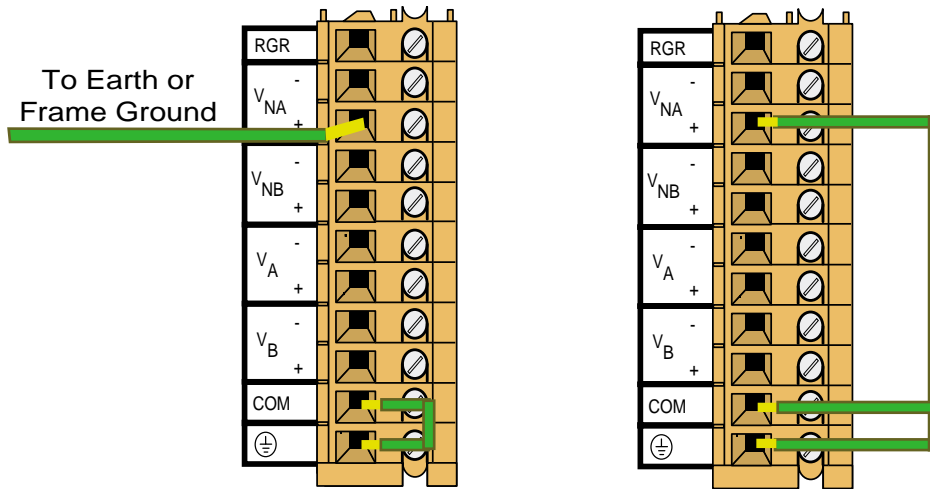

Figure 2-16. Front-Loading Chassis Supplies on Top Ground Strap Methods

2.7.2 For 120/240 AC Powered Systems

When running the system in an AC environment, the VN+, VA+ or VB+ must be referenced to the same grounding reference that the connecting equipment is reference to so as to not produce a floating ground potential as discussed in the -48VDC section previously.

2.7.2.1 Front-Loading Chassis: Power Supplies on Side

The following illustrations detail the possible ground connections for the external power connector of the front-loading chassis with the power supplies on the side.

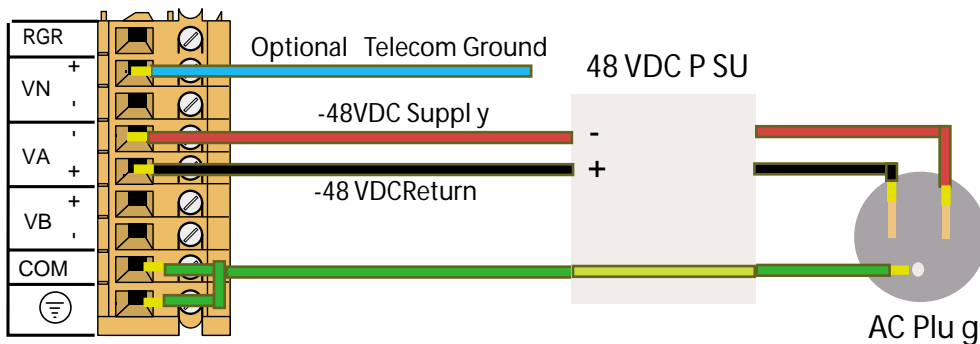
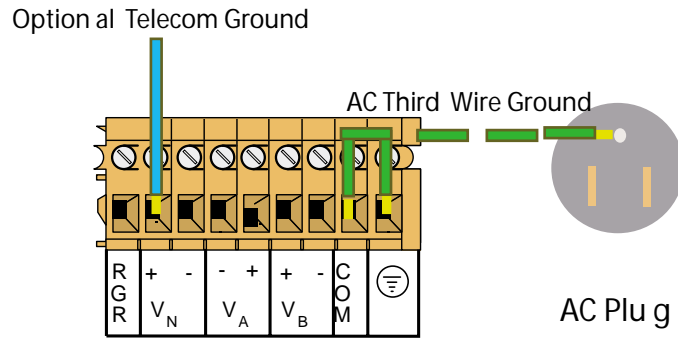

Figure 2-17. External -48VDC Power and Ground to Terminal Block



NOTE: The AC third wire ground is connected to the earth ground lug via an internal connection through the system.

Figure 2-18.AC Ground Connections to Terminal Block

2.7.2.2 Two-Sided Chassis

The two-sided chassis uses the same connections as are used previously for the Front-Loading Chassis with power Supplies on the side covered in Section 2.7.2.1 on page 2-26. Refer to Figure 2-17 on page 2-26 and Figure 2-18.

2.7.2.3 Front-Loading Chassis: Power Supplies on Top

The front-loading chassis has two possible terminal strips. The following illustrations indicate the possible grounding connections when utilizing the two terminal strips.

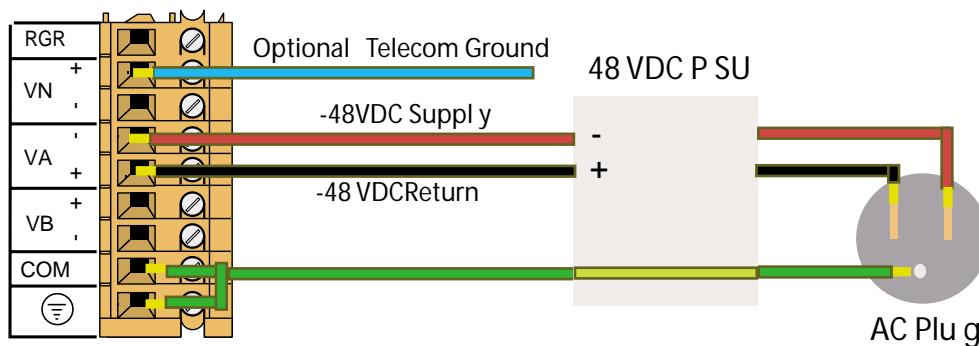
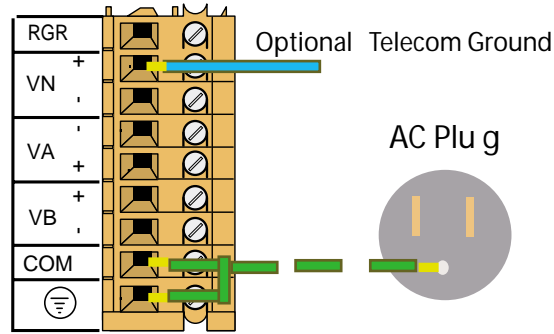

Figure 2-19.Ground Connections for External PSU on Smaller Terminal Strip



NOTE: The AC third wire ground is connected to the earth ground lug via an internal connection through the system.

Figure 2-20. Ground Connections on Smaller Terminal Strip

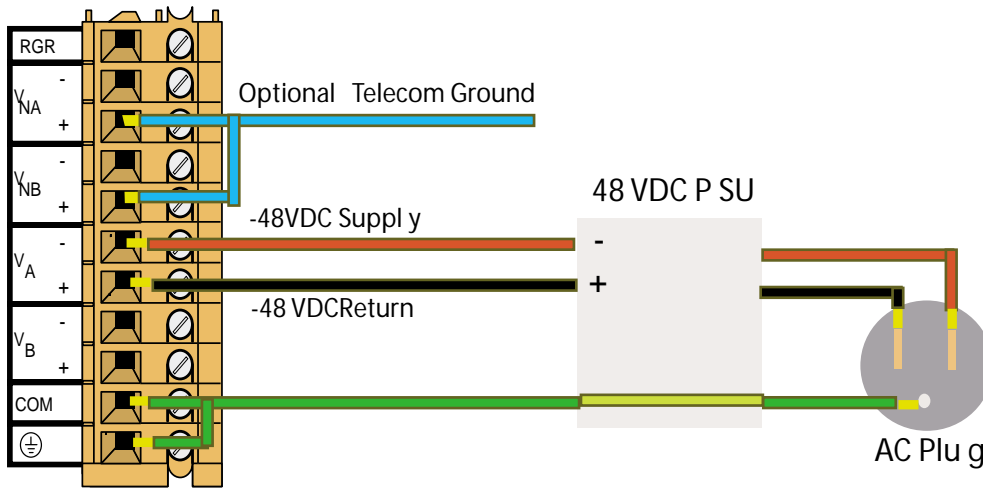
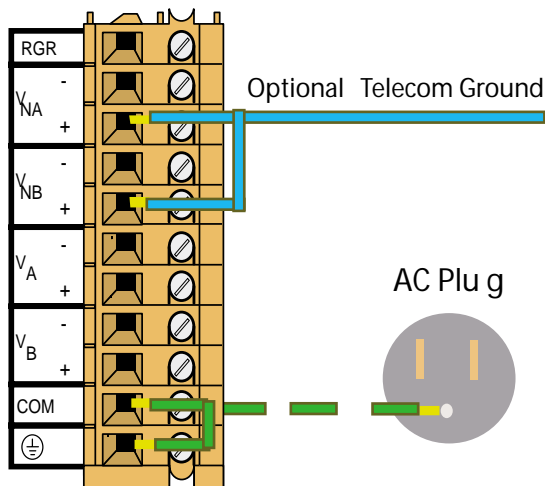

Figure 2-21. Ground Connections to External PSU Large Terminal Strip



NOTE: The AC third wire ground is connected to the earth ground lug via an internal connection through the system.

Figure 2-22. Ground Connections for Large Terminal Strip

2.8 Special Grounding Considerations

2.8.1 External Ringing Generators and other special circumstances

Some installation environments can experience noise on the ringing generator, especially true in environments where an external Ringing Generator is used. When using the external Ringing Generator, it is important to maintain a low resistance between the ground of the external Ringing Generator and the IMACS shelf. For this specific case, measure the resistance between the external Ringing Generator ground and the frame ground of the IMACS shelf. If the measurement is 5 Ohms or less, the installation should not be negatively impacted by the Special Grounding considerations shown in the previous section. If, however, the measurement between the external Ringing Generator and the frame ground of the IMACS shelf is greater than 5 Ohms, then a grounding loop is present, and the terminal strip jumpers should be altered to allow the V_{N+} lead to float, as illustrated below.

2.8.1.1 Two-Sided or Front-Loading Supplies on Side.

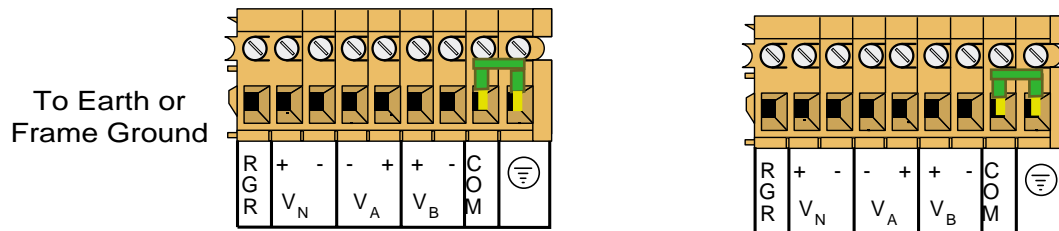

Figure 2-23. Ground Methods with External Ring Generator

2.8.1.2 Front-Loading Chassis Supplies on Top

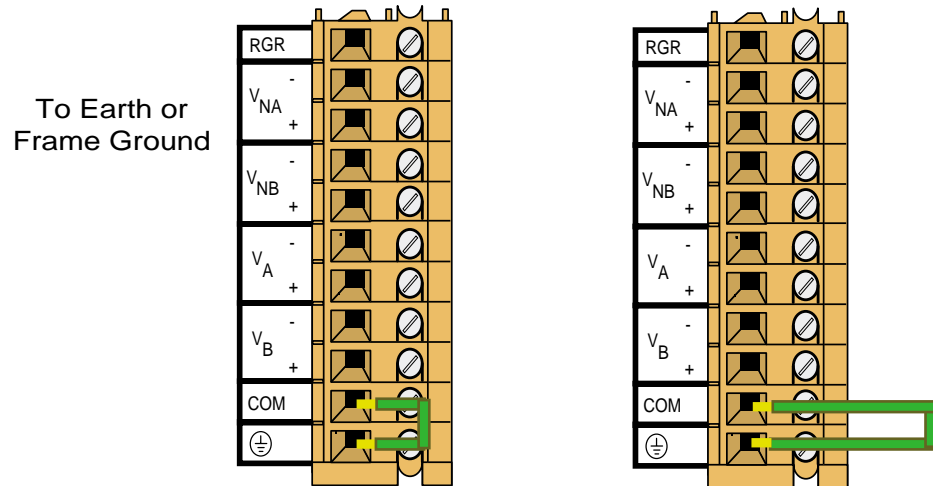

Figure 2-24. Ground Strap Methods with External Ring Generator

2.9 Powering Up the System

After connecting the chassis to the external power sources and making the proper ground connections, apply power to the chassis. Plug the AC power cord into the associated electrical outlets, or turn on the external DC power supply. Then, observe the following front-panel LEDs:

1. The green power LED is lit on the power supply faceplate. If redundant power supplies are used, this LED is lit on both cards.
2. If AC-to-DC converters are installed, their green power LEDs light.
3. If the ringing generator is installed and power is on, the LED on the front panel of the ringing generator should illuminate green.

If these LEDs are not lit, first verify that the external power source is providing power to the chassis, and check the connection between that source and the chassis. Also be sure each card is firmly seated in its chassis slot.

If AC-to-DC converters are used, also check their jumper settings as previously described. If all of these conditions are met, replace the card on which the green LED fails to light; that card is faulty.

2.10 Installing the Other Plug-In Cards

Install the remaining cards into their designated chassis slots.

Some cards have on-board switches or jumpers that you must set before insertion into the chassis. These cards and their settings are summarized at the beginning of this chapter. Also refer to the associated card reference guides for detailed instructions for each card.

2.10.1 Interface Cards (893270 / 893370 / 893470)

Install an Interface (INF) Card (893270, 893370 or 893470) into the IF slot of the chassis. Only one INF card is used in each system. This card provides the connections to the external user interface control systems, alarm reporting facilities, and T1 and/or E1 networks and system docking.

2.10.2 CPU Card (880770)

Install a CPU-7 XCON Card into slot C1 and slot C2 of the system chassis. Refer to the CPU section in this manual for details. After installing these cards, verify that the green LEDs illuminate on their faceplate. If the yellow LEDs illuminate instead, check to see if the CPU card is registered. If the yellow LEDs are still illuminated, replace the associated cards.



Note: The Host Code in the CPU only recognizes the first four digits of any card. For instance 812960 will display 8129 on the screen.

2.10.3 WAN Cards (801060 / 801065 / 801070 / 801470)

Install the Wide-Area Network (WAN) Cards (801050, 801065, 801070 or 801470) into the W1 through W4 chassis slots. But, each system can have up to four WAN cards. Each card also requires the proper type of sub-modules (T1 DSX/E1 CEPT, T1 CSU, Adtran E1/HDSL and PairGain T1/HDSL), depending on whether it interfaces with a T1, E1 or DSL network. Refer to this manual for more information on the various WAN cards currently available.

After installing the WAN cards, verify that the green LEDs illuminate on the WAN faceplates. If their yellow LEDs light instead, check that the T1s are active. If the yellow LEDs are still illuminated, replace the associated cards.

2.10.4 Server Cards

The Integrated Access System offers various types of server cards, including ADPCM (887170), FRS (881160), MCC (881360), PRI-BRI (881162), IPR*4 (883270) and IPR (881161, 883060 and 883160). Each system can have up to three server cards, which fit in slots P1, P2, and P3 of the chassis. Refer to the Server Card Reference Guide for more information on these and other server cards available with this system.

When installing server cards into your system, note that some are labeled “ACS” on their faceplate ejectors, regardless of the type of service they provide. This label identifies the actual card itself, which is physically the same for some server applications. However, an ACS card can be individually software-configured as a frame relay server (FRS), management channel concentrator (MCC), or PRI-BRI server. Therefore, the specific server type for each card (FRS, MCC, PRI-BRI, IPR*4, IPR, etc.) appears only in the user interface screens, which are described in the Server Cards Reference Guide.

2.10.5 User Cards

The system also has numerous user cards for connections to voice and data circuits at the CPE, and alarm cards for system alarm reporting to/from external facilities. The user cards go in slots U1 to U8 of the two-sided chassis and front-loading chassis with power supplies on top. Or, they go in slots P1 to P4 and W1 to W4 of the front-loading chassis with power supplies on the side.

You can install up to seven user cards into a front-loading chassis with power supplies on the side. If you have this chassis type, you must reserve one of the “W” or “P” slots for either a WAN card or a server card.

2.10.6 Connecting Cables to the Cards

After inserting the cards into the system chassis, connect them to the external equipment, using the proper cables. The cards have various types of connectors on their faceplate for those connections.

Some cards have 50-pin Amphenol-type jacks on their faceplate. To connect a cable to this type of jack, first plug the male connector of the cable into the jack and push it in all the way. Then, tighten the mounting screws above and below the cable connector.

For modular (RJ-11 and RJ-48) jacks, push the cable’s mating plug into the jack until it snaps into place. However, do not try to force the plug into the jack.

For DB-9 and DB-25 jacks, first plug the cable’s mating connector firmly into the jack. Then, thread the screws on either side of the cable connector into the standoffs above and below the card jacks, and hand-tighten them.

Refer to *Appendix C. Pinouts* in this guide for more information on the associated card jacks and signal pinouts.

Chapter 3

Chassis Descriptions

3.1 Introduction

This chapter describes chassis models used by the Integrated Access System (IAS). It describes each chassis and the card slot locations.

Three series of chassis models are available:

- 891630 Front-loading chassis with power supplies on the side
- 891830 Front and rear-loading chassis with power supplies on the side, or the *two-sided* chassis
- 891930 Front-loading chassis with enhanced power supply

Four basic types of plug-in cards are available:

- Common cards include the CPU card and the Interface card
- User cards include the Voice card, Data card and the Alarm card
- Server cards include the ADPCM, MCC, PRI-BRI, IPR and IPR*4 cards).
- WAN cards for T1 or E1 networks

These chassis are made of steel and have the improved “v” design card guides that protect the electrical traces of all cards from contact with the chassis. All cards slide into slots in front of a front-loading chassis, or into both sides of a two-sided chassis. Card guides on the top and bottom of the chassis slots align the cards with the connectors for easy insertion.

3.2 Chassis Types

3.2.1 Front-Loading Chassis with Power Supplies on the Side (891630)

Figure 3-1 shows a front-loading chassis with the power supplies on the right side. All cable and card access is from the front of the chassis.

This chassis is made of steel and has punched-steel card guides. This chassis is designed for table top, wall or rack mounting.

The 891630 chassis is equipped with two CPU card slots, C1 and C2, and a common bus. The combination slots for this chassis are P1 to P4, and W1 to W4. When used for voice, data, terminal interface, and/or alarm cards, these slots are referred to as slots U1 through U8.

Slot P4 is not supported for a server card. Only user cards can be installed in the P4 slot. Table 3-1 illustrates the suggested mapping for this chassis type. Table 3-1 also lists the card slot locations for the 891630 chassis. Refer to this table when determining your 891630 chassis card configuration.

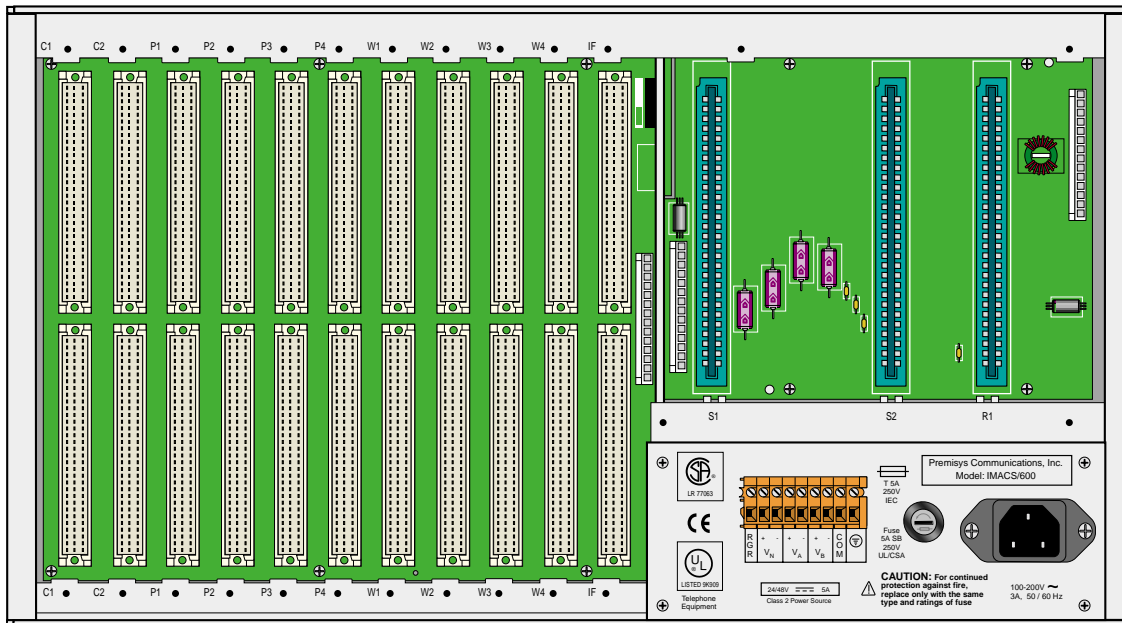

Figure 3-1. Front-Loading 891630 Chassis with Power Supplies on the Side

Table 3-1. Card Slots for Front-Loading 891630 Chassis with Power Supplies on the Side

Type of Card	# of Cards	Slots Used	Notes
CPU	1 or 2	C1, C2	One required in either slot
Server	0 to 3	P1, P2, P3	ADPCM, MCC, PRI-BRI, IPR*4 and IPR (P4 is not used for Server Cards)
WAN	1 to 4	W1 to W4	One required
Interface	1	IF	Required
Alarm	0 to 7	P1-4, W1-4	Internal/External, any user slot
E&M Voice	0 to 7	P1-4, W1-4	2/4-wire voice, any user slot
FXS Voice	0 to 7	P1-4, W1-4	2-wire voice, any user slot
FXO Voice	0 to 7	P1-4, W1-4	2-wire voice, any user slot
BRI Data	0 to 7	P1-4, W1-4	BRI, any user slot
DS0-DP Data	0 to 7	P1-4, W1-4	The DS0-DP card Contra directional/Codirectional Data Unit (DS0-DP/G.703) provides a 64 kbps interface to a DS0 time slot of a T1 or E1 network. This is a 4-wire data card and inserts into any user card slot.
HSU Data	0 to 7	P1-4, W1-4	High-speed data, any user slot
OHSU Data	0 to 8	U1-U8	High-speed data, any user slot
OCU-DP Data	0 to 7	P1-4, W1-4	The Office Channel Unit - Dataport cards interface directly with Data Service Units/Channel Service Units (DSU/CSUs) support data traffic up to an including 64 kbps. This is a 4-wire data card and inserts into any user card slot.
SRU Data	0 to 7	P1-4, W1-4	Sub-rate data, any user slot
Main Power (AC/DC)	1 or 2	S1 and S2	AC or DC power supplies
Optional Power	0 or 1	S2	AC-to-DC converter (-48V)
Optional Ringer	0 or 1	R1	Ringling generator

3.2.2 Two-Sided 891830 Chassis

Figure 3-2 shows the front of a two-sided chassis. This chassis accepts cards from both the front and rear. It is made of steel and has punched-steel card guides.

The front of the two-sided chassis holds up to two CPU cards, slots C1 and C2, and up to three server cards slots, P1 to P3, and up to four WAN cards slots, W1 to W4. The power supplies occupy slots F1 and F2.

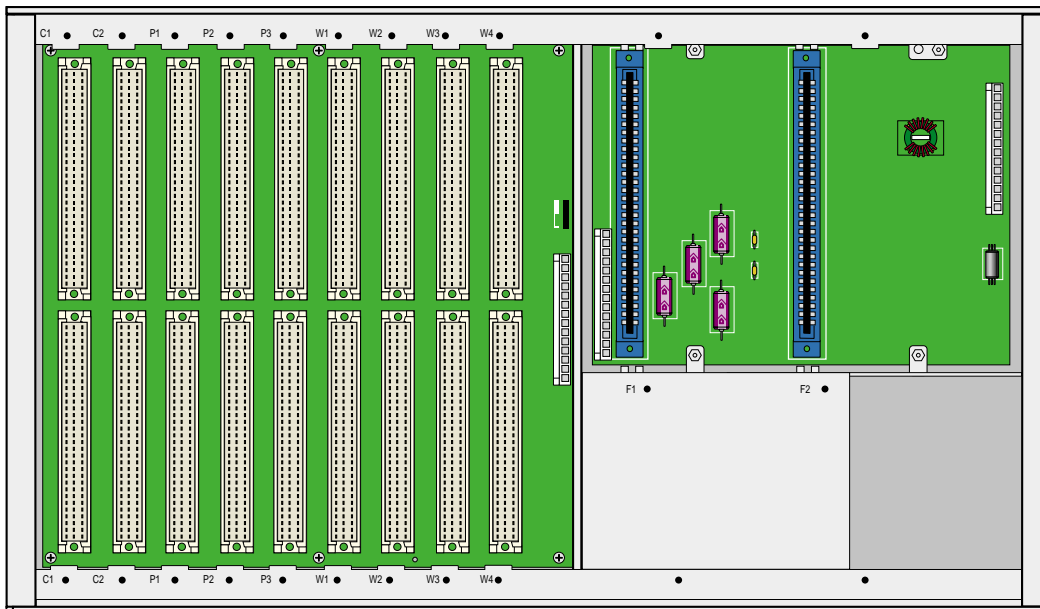

Figure 3-2. Two-Sided Chassis Front View (891830)

This chassis is designed for table-top or rack mounting.

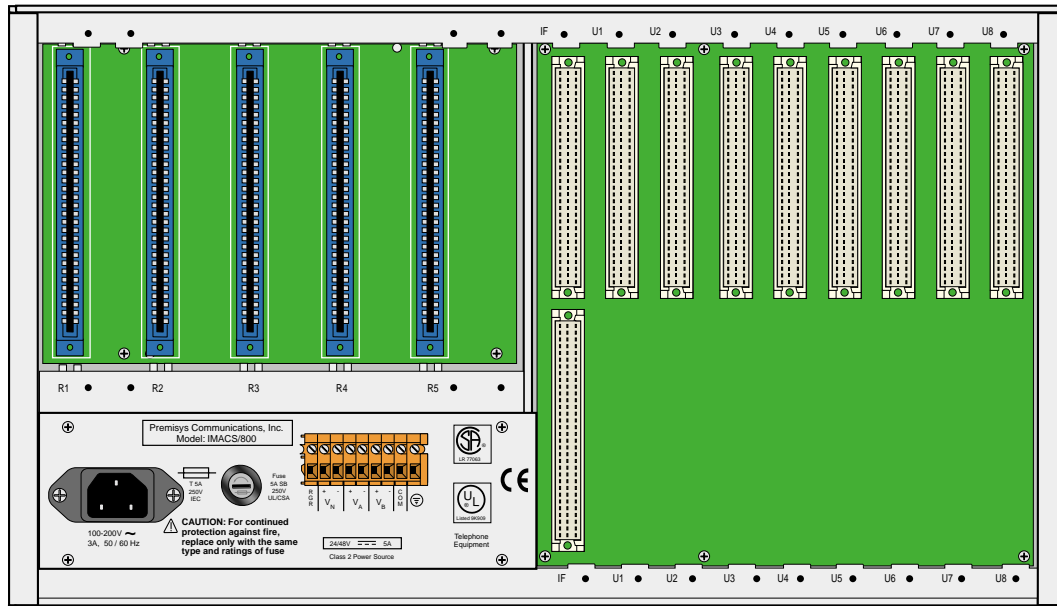

Figure 3-3. Rear View of Two-Sided 891830 Chassis

Figure 3-3 shows the rear of the two-sided chassis. The eight user slots U1 through U8 hold a combination of user cards. The slot labeled IF holds the Interface card.

Slots R1 to R5 hold the optional AC-to-DC power converters and ring generators.

Use Table 3-2 to determine your two-sided chassis card slot configuration.

Table 3-2. Two-Sided Chassis Card Slots

Type of Card	# of Cards	Slots Used	Notes
CPU	1 or 2	C1, C2	One required in either slot
Server	1 to 3	P1, P2, P3	ADPCM, MCC, PRI-BRI, IPR*4 and IPR (P4 is not used for Server Cards)
WAN	1 to 4	W1-W4	One required
Interface	1	IF	Required
Alarm	0 to 8	U1-U8	Internal/External, any user slot
E&M Voice	0 to 8	U1-U8	2/4-wire voice, any user slot
FXS Voice	0 to 8	U1-U8	2-wire voice, any user slot
FXO Voice	0 to 8	U1-U8	2-wire voice, any user slot
BRI Data	0 to 8	U1-U8	BRI, any user slot
DS0-DP Data	0 to 8	U1-U8	The DS0-DP card Contra directional/Codirectional Data Unit (DS0-DP/G.703) provides a 64 kbps interface to a DS0 time slot of a T1 or E1 network. This is a 4-wire data card and inserts into any user card slot.
HSU Data	0 to 8	U1-U8	High-speed data, any user slot
OHSU Data	0 to 8	U1-U8	High-speed data, any user slot
OCU-DP Data	0 to 8	U1-U8	The Office Channel Unit - Dataport cards interface directly with Data Service Units/Channel Service Units (DSU/CSUs) support data traffic up to an including 64 kbps. This is a 4-wire data card and inserts into any user card slot.
SRU Data	0 to 8	U1-U8	Sub-rate data, any user slot
Main Power (AC/DC)	1 or 2	F1, F2	AC or DC power supplies
Optional Power	0 to 2	R1-R5	AC-to-DC converter (-48V)
Optional Ringer	0 to 5	R1-R5	Ringling generator

3.2.3 Front-Loading 891930 Chassis with Enhanced Power Supply

Figure 3-4 shows the front-loading chassis that uses the 8908 enhanced power converter. This is a tall chassis in which the two power supply slots (P1/P2) are in the upper right.

This chassis is designed for table top, wall or rack mounting. All cable and card access is from the front of the chassis.

Slots P1 to P3 will hold three server cards. Slots W1 to W4 hold four WAN cards. Slots U1 through U8 will hold eight user cards.

Slots P1 and P2 hold up to two power supply models 8901 or 8902. Slots R1 and R2 hold up to a maximum of two ring generators model 890620.

Slots NS1 and NS2 are the two low power slots for the AC-to-DC converters models 8903 and 8905. Slots HP1 and HP2 are for the two high power AC-to-DC converters model 8908.

Note: *Cannot mix High/Low Power Converters in the Power Enhanced Power Chassis.*

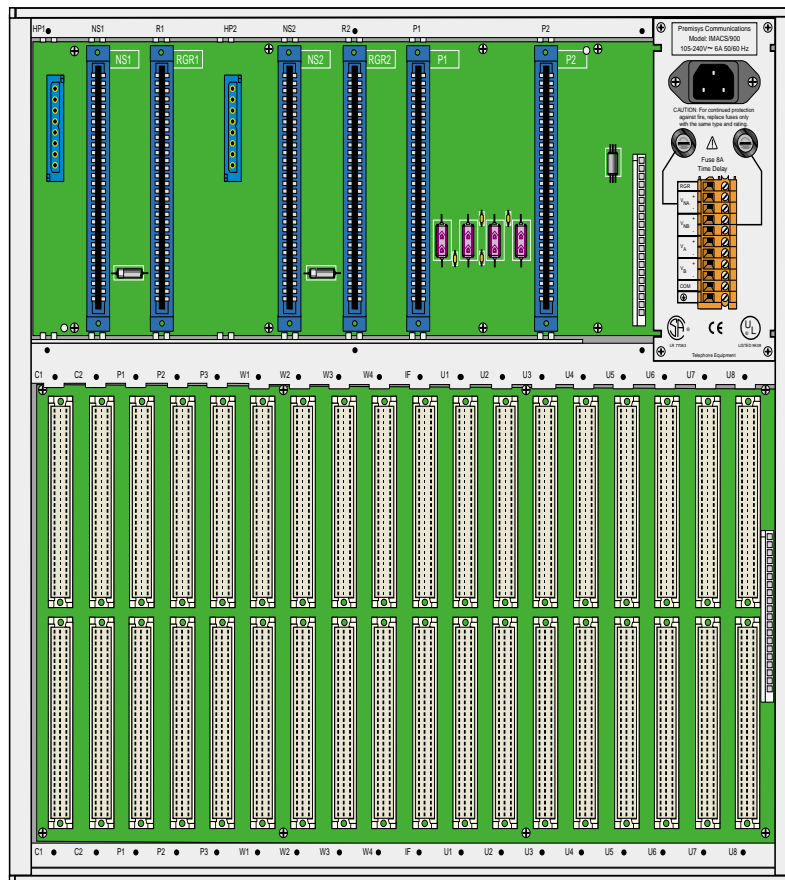

Figure 3-4. Power Enhanced Chassis (891930)

The power enhanced chassis works in a specific environment relating to applications using BRI cards. If your environment requires this type of configuration, notify your system administrator for applications design and configuration setup.

This chassis can accept a total of four power supplies. Two are standard power supplies, and two are load sharing power supplies.

One load sharing power supply is used as a redundant power supply, and the other is used as the primary power supply. See Figure 3-5 for wiring details.

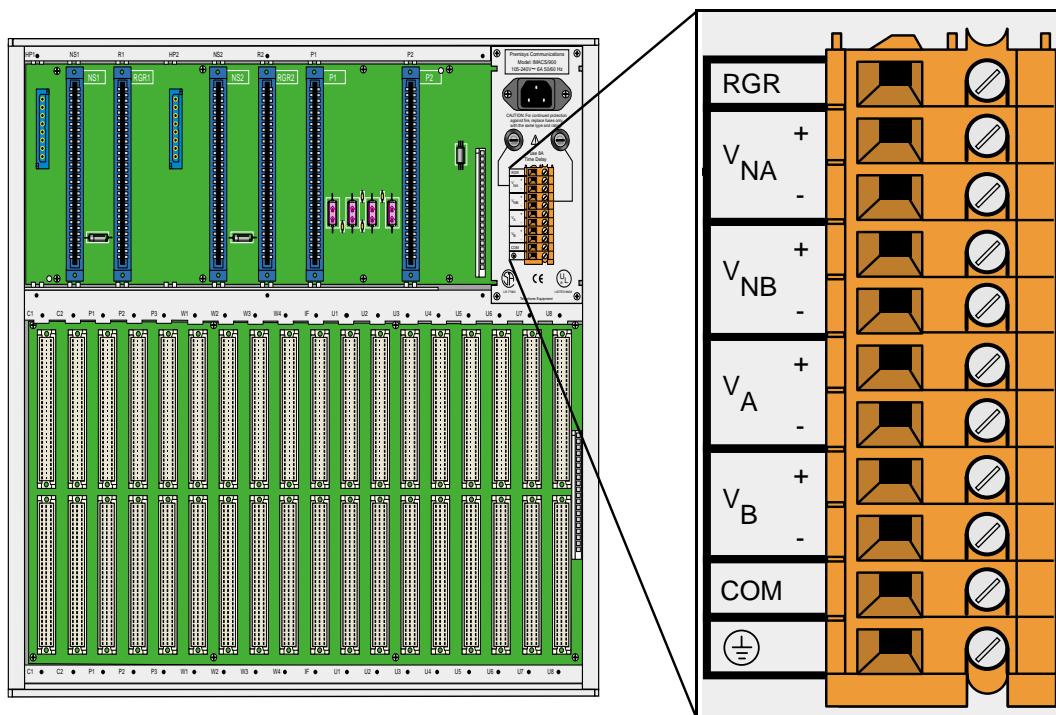
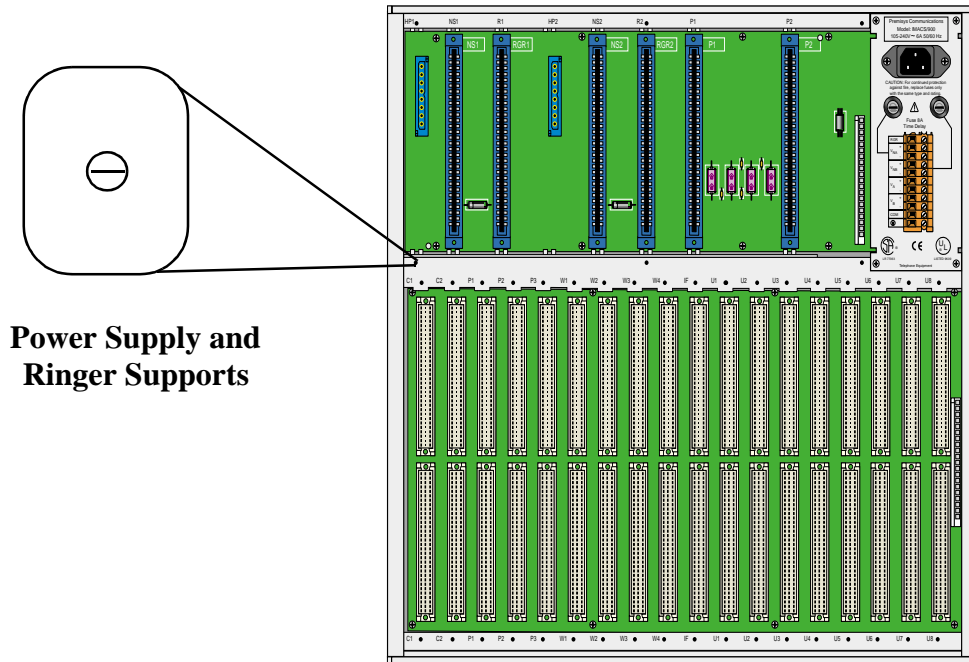

Figure 3-5. External Power Source for the Power Enhanced Chassis (891930)

Notes:

4. V_{NA} (+ & -) are dual -48VDC feeds for the data backplane when -48VDC is to be output from the user card. V_{NA} and V_{NB} are independently protected by 8 amp fuses located on the front panel above the TB connector.
5. V_A (+ & -) and V_B (+ & -) are dual feeds for the power supplies located in slots P1 & P2 respectively (see note 3).
6. Power to V_{NA} (+ & -) and V_{NB} (+ & -) must be supplied by an external -48VDC power source or jumpered from either V_A (+ & -) or V_B (+ & -) if -48VDC power is required on the data backplane.



Power Supply and Ringer Supports

Figure 3-6. Power Supply and Ringer Supports for Power Enhanced Chassis (891930)

A more detailed description of this chassis and its power capabilities is given in chapter 3.

Table 3-3 shows the card slots for the front-loading chassis with the power supplies on top. Use Table 3-3 to determine your chassis card configuration.

Table 3-3. Card Slots for Front-Loading Chassis with Enhanced Power Supplies on Top

Type of Card	# of Cards	Slots Used	Notes
CPU	1 or 2	C1, C2	One required in either slot
Server	1 to 3	P1, P2, P3	ADPCM, MCC, PRI-BRI, IPR*4 and IPR (P4 is not used for Server Cards)
WAN	1 to 4	W1-W4	One required
Interface	1	IF	Required
Alarm	0 to 8	U1-U8	Internal/External, any user slot
E&M Voice	0 to 8	U1-U8	2/4-wire voice, any user slot
FXS Voice	0 to 8	U1-U8	2-wire voice, any user slot
FXO Voice	0 to 8	U1-U8	2-wire voice, any user slot
BRI Data	0 to 8	U1-U8	BRI, any user slot
DS0-DP Data	0 to 8	U1-U8	The DS0-DP card Contra directional/Codirectional Data Unit (DS0-DP/G.703) provides a 64 kbps interface to a DS0 time slot of a T1 or E1 network. This is a 4-wire data card and inserts into any user card slot.
HSU Data	0 to 8	U1-U8	High-speed data, any user slot
OHSU Data	0 to 8	U1-U8	High-speed data, any user slot
OCU-DP Data	0 to 8	U1-U8	The Office Channel Unit - Dataport cards interface directly with Data Service Units/Channel Service Units (DSU/CSUs) support data traffic up to an including 64 kbps. This is a 4-wire data card and inserts into any user card slot.
SRU Data	0 to 8	U1-U8	Sub-rate data, any user slot
Main Power (AC/DC)	1 or 2	F1, F2	AC or DC power supplies
Optional Power	0 to 2	NS1-NS2	AC-to-DC converter (-48V) 100W
Optional Ringer	0 to 2	R1-R2	Ring generator
Enhanced Power	0 to 2	HP1-HP2	AC-to-DC converter (-48V) 300W

3.3 U.S. and European Chassis Configuration

The chassis can be configured to comply with either U.S. (domestic) or European electrical safety standards by setting a jumper inside each chassis. Refer to *Chapter 3. Installation* for details.

In order to meet the safety requirements of 73/23/EEC, it was necessary to increase the separation of the backplane traces for -12VDC and -48VDC. This was accomplished by creating a second -12VDC trace that has sufficient separation from the -48VDC trace. Newer cards and chassis have been designed with a jumper (CE) to allow the user to select which trace to use. Older cards which are not equipped with the CE jumper require the chassis jumper to be in the US position while newer cards equipped with the CE jumper will work in either position as long as the jumper on the cards and the chassis is in the same position. If there is a mismatch of the cards and chassis, the cards will not power up correctly.

Chapter 4

Applications

4.1 Introduction

By virtue of its open design, this system is capable of serving many different roles within a network. Some of the various functions the system can perform include:

- Cross-Connect Functionality
- Leased Line Provisioning
- Video Broadcast
- Sub-Rate Data Transport
- Data Backup and Bandwidth on Demand
- Interactive Distance Learning/Tele-Medicine

Sample application examples are detailed in this chapter. These examples are meant neither to be exhaustive nor definitive, but simply to detail possible applications for this system.

While the system is designed to run multiple simultaneous applications, not all applications can run at the same time on the same chassis, based on conflicting resource allocations and slot requirements. If you are unsure about whether you can run certain applications simultaneously on a single system, consult with your network administrator regarding network design considerations.



Note: IAD is an example for any type of Integrated Access System used in the field for which these applications can be implemented.

4.2 Voice Modules

4.2.1 Foreign Exchange Station (FXS) Card (812960)

This Integrated Access System supports two variants of Foreign Exchange Station (FXS) cards:

- 812960 FXS Card provides eight 2-wire analog ports with a terminating impedance of 600 ohms.

FXS cards can be installed in any User Slot in the system chassis. FXS cards encode the incoming analog voice signals into 64 Kbps PCM format before transmission onto the network. Each FXS card provides a single 50-pin female AMPHENOL connector (RJ27X).

All port parameters are software configurable on a port by port basis. The Mode setting specifies whether the port is to be used for standard Foreign Exchange Station, Foreign Exchange Software Defined Network, Private Line Automatic Ringdown (PLAR), or Dial Pulse Origination applications. For example in the case of a PLAR circuit, the port can be programmed to provide Ringback Tone towards the caller. The Type setting specifies Loop Start, Loop Forward, Ground Start, Ground Start Immediate and Ground Start Automatic operation. If the PLAR mode is selected, then the two options supported under Type are "D3" and "D4" which meet the pre-1988 and post-1988 specifications for PLAR circuits. The PCM Coding options supported include μ -Law, A-Law and inverted A-law, and the user may also select the Trunk Conditioning mode (busy or idle) that should be applied towards the attached equipment should the WAN facility that the port is connected to fails. In addition, both the Transmit (Tx) and Receive (Rx) TLP levels can be set in increments of 0.1 dB. The Tx TLP range is from -10.0 dB to +5.0 dB. The Rx TLP range is from -10.0 dB to +2.0 dB.

The user may also specify, on a port-by-port basis, whether to use North American ANSI standard ABCD signaling (which is the default) or ITU (CCITT) ABCD signaling by turning the signaling conversion setting "on" or "off". The trans-hybrid balance may be specified as one of eight values as well as for a customized user-specified terminating impedance. At the present time, all eight values are identical and are set for a terminating impedance of 600Ohms @ 2.15 μ F.

Software-initiated testing and diagnostics supported on FXS cards include the setting of both analog and digital loopback towards the network and the generation of a Digital MilliWatt (DMW) signal on a port-by-port basis. A robust set of test functions allow the user to monitor and set the state of the analog Tip and Ring leads of any FXS port and to set and monitor the state of the ABCD signaling bits of the digitized voice signal. In cross-connect systems, the Test functionality also includes the ability to generate test tones (300Hz, 1 kHz, 3 kHz and "quiet") and transmit those toward either the user side or the network side of the system. FXS cards can use the voice-compression features of the ADPCM and LBRV resource cards.

4.2.2 Foreign Exchange Office (FXO) Card (813970)

This Integrated Access System supports three variants of Foreign Exchange Office (FXO) cards:

- 813970 FXO Card provides eight 2-wire analog ports with terminating impedance of 600 ohms with improved ground-start signaling. This card requires release 5.1.9 or 5.4.7.

FXO cards can be installed in any of the User Slots of the system chassis. FXO cards encode the incoming analog voice signals into 64 Kbps PCM format before transmission onto the network.

A Ring Generator is required if one or more FXO ports in a system are programmed to operate in Manual Ringdown (MRD) mode.

In addition, a physical jumper must be set on the FXO card for each port programmed for MRD operation. Each FXO card provides a single 50-pin female AMPHENOL connector (RJ27X).

The MRD mode also requires the setting of physical jumpers. The Signal setting specifies Loop Start, Loop Forward, Ground Start, R2, and Immediate R2 operation. In "fxodn" and "dpt" modes, the user may also specify the wink duration time and wink delay from 0.1 seconds to 9.9 seconds in 0.1 second increments.

All port parameters are software configurable on a port by port basis. The Mode setting specifies whether the port is to be used for standard Foreign Exchange Office, Foreign Exchange Software Defined Network, Dial Pulse Terminate, or Manual Ring Down (MRD).

The PCM Coding options supported include "mu-law", "A-law" and inverted A-law. The user may select the Trunk Conditioning mode ("busy" or "idle") that should be applied towards the attached equipment should the WAN facility that the port is connected to fail. In addition, both the Transmit (Tx) and Receive (Rx) TLP levels can be set in increments of 0.1 dB. The Tx TLP range is from -10.0 dB to +5.0 dB. The Rx TLP range is from -10.0 dB to +2.0 dB.

The user may also specify, on a port-by-port basis, whether to use North American ANSI standard ABCD signaling (which is the default) or ITU (CCITT) ABCD signaling by turning the signaling conversion setting "on" or "off."

The trans-hybrid balance may be specified as one of eight values (known as "set1" through "set8") as well as for a customized user-specified terminating impedance ("user"). All eight values are identical and are set for a terminating impedance of 600Ohms @ 2.15 μ F in the case of the Model 813960 FXO cards.

Software-initiated testing and diagnostics supported on FXO cards include the setting of both analog and digital loop backs towards the network and generating a Digital MilliWatt signal on a port-by-port basis. A robust set of Test functions allow the user to monitor and set the state of the analog Tip and Ring leads of any FXO port.

It also sets and monitors the state of the digitized voice signal's ABCD signaling bits. In cross-connect systems, the Test functionality also includes the ability to generate test tones (300Hz, 1 kHz, 3 kHz and "quiet") and transmit those toward either the user side or the network side of the system.

4.2.3 E&M Card (811960)

This Integrated Access System supports two variants of E&M cards:

- 811960 E&M Card supports eight 4-wire E&M or Transmission Only (TO) ports

The 811960 E&M card offers an extended Transmit TLP range (-17.5 to +14.5dB) to better support dedicated 4-wire modem applications. This may be required in situations when specific types of modems being connected to the ports cannot, or will not, change their output power levels. Modems can only be connected with the E&M when placed in TO mode.

E&M cards can be installed in any of the User Slots of the system chassis. E&M cards encode the incoming analog voice signals into 64 Kbps PCM format before transmission onto the network. Each E&M card provides a single 50-pin female AMPHENOL connector (RJ27X). All three cards support E&M signaling types I, II, IV, and V.

Most port parameters are software configurable on a port by port basis including the Mode of each port ("E&M", "E&MR2" or "TO"). The PCM Coding to be used is either u-law, a-law or a-inv (for inverted a-law). The Trunk Conditioning (busy or idle) is configured on the equipment in case the WAN facility that the port is connected fails.

The user may also specify, on a port-by-port basis, whether to use North American ANSI standard default, ABCD signaling, or ITU (CCITT) ABCD signaling by turning the signaling conversion setting "on" or "off".

For the Model 810860 2-wire E&M card only, the trans-hybrid balance may be specified as one of eight values as well as for a customized user-specified terminating impedance ("user"). All eight values are identical and are set for a terminating impedance of 600 Ohms @ 2.15µF.

Software-initiated testing and diagnostics supported on E&M cards include the setting of both analog and digital loop backs towards the network and the generation of a Digital MilliWatt signal on a port-by-port basis. A robust set of test functions allow the user to monitor and set the state of the analog E and M leads of any port and to set and monitor the state of the ABCD signaling bits of the digitized voice signal. In cross-connect systems, the Test functionality also includes the ability to generate test tones (300Hz, 1 kHz, 3 kHz and "quiet") and transmit those toward either the user side or the network side of the system.

4.2.4 Voice Channel Bank Application

This is the simplest application which can be used by a service provider. The Integrated Access System is used in this configuration when one or more digital T1/E1 trunks are needed to interface with analog PBXs or key systems at the customer premises. In the US, the break-even point for bringing in a T1 trunk as opposed to multiple analog lines is typically 6 analog lines. A single Integrated Access System can be used to provision up to 62 analog POTS lines (FXS, FXO, E&M) on digital Central Office switches as shown in Figure 4-1.

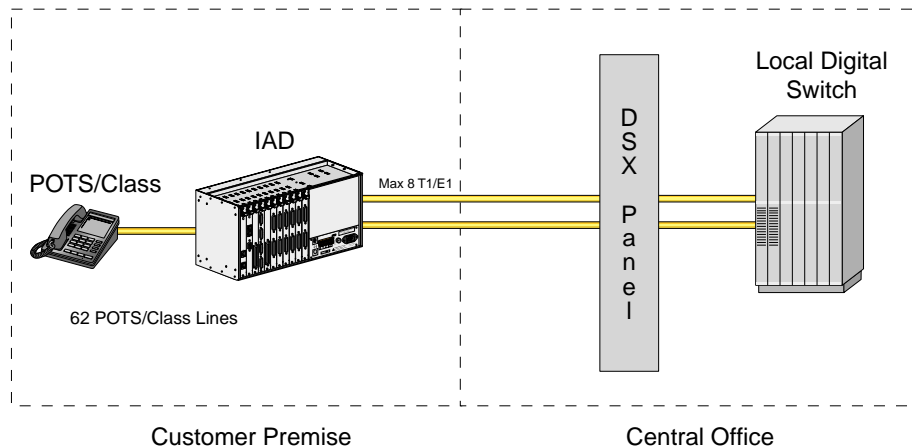

Figure 4-1. An IAD used as a Voice Channel Bank

This Integrated Access System can also be deployed in applications which do just the reverse of voice channel banks. This is most likely to be found in wireless local loop applications in which the wireless service provider may use a state-of-the-art wireless local loop. The output of the wireless base station is normally a T1/E1. However, the existing PSTN may still have analog switches. The Integrated Access System is used to convert from robbed-bit signaling/CAS to analog trunks.

The voice channel bank platform can be upgraded to provide an array of additional services just by adding application modules to the chassis. It comes with a built-in suite of testing and diagnostics tools which enhance the service and support capabilities significantly.

4.2.5 TR008 Application

BellCore's TR-TSY-000008 standard describes the requirements necessary for a Local Digital Switch (LDS) to connect to a remote terminal (RT) across a T1 (1.544Mbps) digital interface. The standard allows supporting from one to four T1s per RT without facility Automatic Protection Switching (APS), and three to five T1s with facility APS.

The LDS can interface the RT in Mode I (no concentration), Mode II (2:1 concentration), and Mode III (24 special-service circuits on 24 DS1 time-slots). TR008 supports traditional POTS, CLASS, and Coin services but does not support ISDN BRI.

If the service provider deploys a channel bank at the customer premise that does not provide TR008 capability then it needs a 1/0 DCS with TR008 capability at the central office to integrate with the LDS.

In addition to the many Integrated Access System functionality's, the system also supports TR008 switch integration. The Integrated Access System with TR008 operation can connect directly to the LDS, eliminating the need for the 1/0 DCS as shown in Figure 4-2.

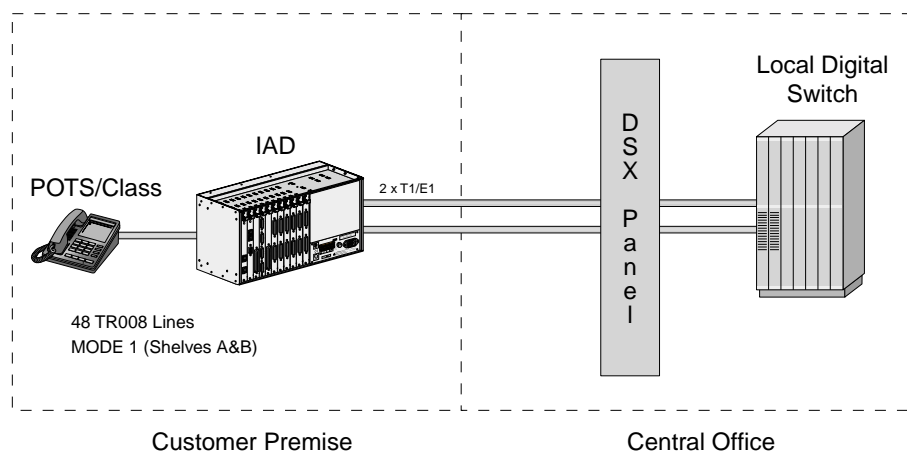

Figure 4-2.IAD using TR008

The TR008 feature can support 48 lines on 2 T1 links. This is an ideal vehicle to provide integrated POTS services for line sizes of 48 and under. This system supports Mode I, Shelf A&B of TR008 specification. The system supports extensive testing and diagnostics capabilities which minimizes troubleshooting and allow high service levels.

4.2.6 T1-E1 Conversion Application

The Digital Access and Cross-connect System (DACS) capabilities and the signaling and companding conversion features of the Integrated Access System can be used to provide gateway functionality between a DS1 transport network and an E1 transport network. See Figure 4-3 for an illustration of this capability.

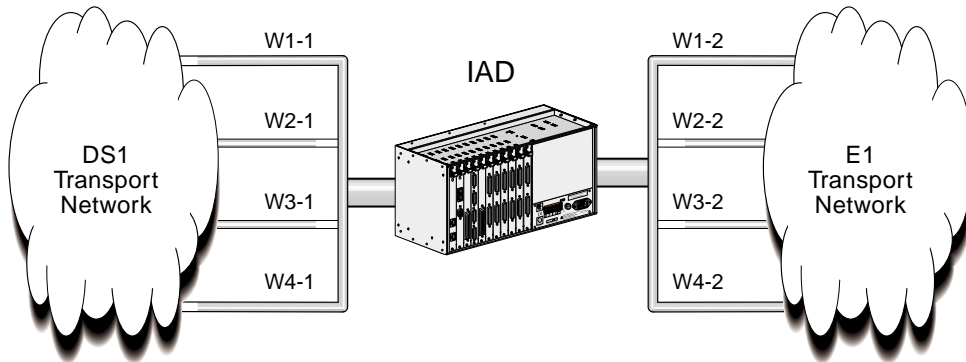

Figure 4-3. IAD using T1/E1 Conversion

Depending on the application, the signaling conversion can be set by the user to ITU-to-ANSI; ANSI-to-ITU or None. Similarly, the companding can be set by the user to A-Law-to- μ -Law; μ -LAW-to-A-Law or None. As shown in the figure above, each WAN card must be configured with one port for DSX1 and one for CEPT. A cross connection circuit must be made for each DS1 to E1 DSO re-assignment. Time Slots 0 and 16 cannot be used on the E1 link. Time slot 0 is used for timing and time slot 16 is used for Channel Associated Signaling (CAS). TS16 is available in data-only applications.

4.3 Data Modules and Applications

This Integrated Access System supports multiple user cards for transport of digital data.

4.3.1 HSU Card (820260 820360 821260 821460 821570 & 821660)

The HSU card allows the connection of high speed data terminal equipment (DTE) and data communications equipment (DCE) to WAN links, server cards (ADPCM) or another HSU card. The HSU card also provides low or mid-density connectivity for local, synchronous peripherals such as, LAN Bridge/Routers and legacy SNA/SDLC devices. Additionally, these high speed data cards also provide broadcast functionality for point to multi-point operation suitable for applications such as video conferencing. When used in conjunction with an 8840 PRI Server Card, the HSU card can be used to provide switched data application functionality. (i.e. telephone call centers). All HSU cards can be installed in any of the User Slots in an Integrated Access System chassis.

The various models of the HSU Card are as follows:

- 820260 HSU card supports two RS530/RS449 data ports. It can also support V.35 and RS232 data through the use of the appropriate Personality module. Personality modules can be intermixed on the same RS530 card.
- The 820360 HSU Trunk Card supports two V.11/X.21 data ports. The ports may be configured as user ports, or can be used as externally clocked network interface ports.
- The 821260 HSU card supports two “true” V.35 synchronous data ports.
- The 821360 HSU Card provides two ports. Each port can be individually configured to support RS530 or V.35 devices. The 821360 also supports V.25bis dialing commands (an in-band dialing protocol) and RS366 dialing through the use of separate DB-15 pin RS366 port connectors on the rear of the card. The 821360 also has a proprietary in-band performance monitoring system.
- The 821460 HSU card supports two (2) V.35 synchronous data ports. The ports may be configured as user ports, or can be used as externally clocked network interface ports.
- The 821570 HSU card provides four ports which can be individually configured to support RS530, RS449/422, and V.35. devices.
- The 821660 HSU card provides four-ports which support four EIA530/A or V.35 data ports. The selection EIA530, EIA530A, or V.35 is made on a port-by-port basis using on-board switches. This enhanced HSU card is a derivative of the 821570 card, with better clock performance, a true V.35 interface and a receiver clock invert option.

Each port on a HSU can be independently configured to operate at speeds of Nx56 or Nx64 Kbps, where N equals 1 to 24 in T1 mode or 1 to 31 in E1 mode. In addition to the data rate, each synchronous port's Transmit Clock can be programmed for Internal or External modes and both the Clock and Data Polarity may be inverted through software.

The External Transmit Clock mode and the Inverted Clock Polarity mode may be useful in ensuring that both the Transmit Clock and the Transmit Data are in sync when they reach the HSU port.

This should occur when the HSU port and the attached device are connected over a long cable. The Data Polarity may be inverted to ensure the density for Nx64 Kbps data circuits supporting HDLC-based protocols that are connected to non-B8ZS T1 facilities.

The “Clear To Send” control lead may always be set to high, low or local mode. In local mode, the CTS signal reflects the state of the Request To Send (RTS) signal that is received from the attached DTE device. In that mode, the delay between RTS and CTS is software set-able, with options of 0, 30, 60 or 100 milliseconds. Additionally, if the HSU port is programmed to operate at Nx56 Kbps, then RTS will be transmitted end-to-end and presented as RLSD at the far end of the circuit.

Software-initiated diagnostics support include the setting of local loop backs towards either the network or the attached DTE equipment. Additionally, a remote loop back function allows the HSU card to generate three DDS-compatible latching loop back codes for the far-end OCU, CSU and DSU equipment. Similarly, the HSU data port may be programmed to detect and respond to both latching and non-latching DDS-format OCU, CSU and DSU loop back codes initiated from the remote end of the circuit. A time-out option authorizes the HSU port to automatically release the loop back after ten minutes. This feature applies to an HSU port that is running at 56 Kbps or for super-rate circuits if the loop back code is transmitted in the first super-rate's DSO. The card can also generate and recognize two industry standard in-band loop-up and loop-down codes that act on the entire super-rate circuit. Those are the ITU (CCITT) V.54 code and the ANSI Fractional T1 code.

Additionally, the integral Bit Error Rate Tester (BERT) can be used to generate test patterns and route those towards the WAN facility. These test patterns can then be used to verify synchronization and measure circuit quality. For further information regarding Performance Monitoring and Diagnostic Capabilities, see Chapter 8, System Testing and Diagnostics.

Applications

There are several business applications the Integrated Access System equipped with an HSU card supports.

- LAN to LAN
- LAN to WAN to LAN
- Work Station to Computer
- Computer to Computer
- Compressed Video
- CAD/CAM
- Call Center

4.3.2 HSU Application Example

A major Health Maintenance Organization has numerous locations which have a Central main hospital facility and smaller satellite facilities. The HMO cannot afford to fully staff each main and satellite site with specialist. As patients enter the satellite facilities, video and audio sessions can be established with the specialists at the Main hospital. Although the satellite sites are not equipped with Intensive Care Units, emergencies can be admitted and support solicited from the Main hospital personnel as shown in Figure 4-4.

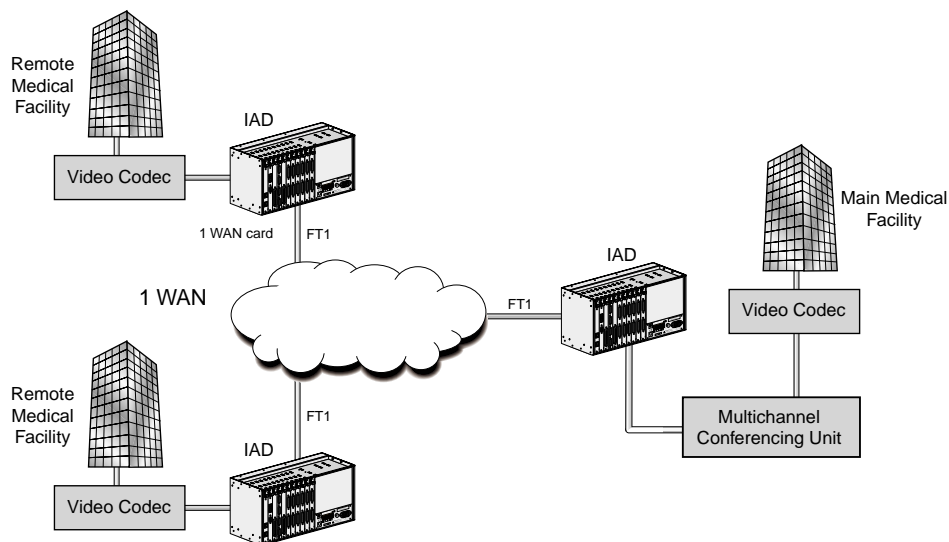

Figure 4-4. Point to MultiPoint One-Way Video and Audio using HSUs

4.3.3 OHSU Card (823760)

The OHSU card allows the connection of IEEE C37.94 compliant teleprotection equipment to WAN links. OHSU cards can be installed in any of the User Slots in an Integrated Access System chassis.

The OHSU Card contains two IEEE C37.94 compliant optical interface ports. These ports are designed to function as the multiplexer equipment end of the interface.

Designed to C37.94 requirements, the OHSU ports are the timing source for the optical links.

Each port of the OHSU allows the user to map the payload (up to 12 x 64kbps) of the C37.94 link onto the IMACS WAN link.

Software-initiated diagnostics support includes the setting of local loop backs towards either the network or the attached teleprotection equipment.

The current optical link status can be checked using the OHSU main screen and the LED for each port on the front panel.

4.3.4 SRU Card (822060)

The SRU card enables high density connectivity for local, synchronous or asynchronous peripherals. The 822060 SRU Card allows connections of up to ten RS-232, low-speed and medium-speed (300 bps to 38.4 kbps) data terminals to the Integrated Access System. Since an SRU port does not require a complete 64Kbps time slot, the Sub-Rate card allows you to multiplex a number of devices into a single, subdivided time slot on a WAN card. SRU card ports can also be multiplexed with voice traffic on an ADPCM engine.

Each RS-232 port can be independently programmed for synchronous (including HDLC) or asynchronous operation. Synchronous operation is available at speeds of 2.4 Kbps up to 38.4 Kbps while for asynchronous the range is 300 bps up to 38.4 Kbps. Each synchronous port can receive timing from either the DTE device or the system clock.

If the DTE supplies the transmit clocking, it must be synchronized with the system clocking source. For each asynchronous data port, the stop bits, data bits and parity are user configurable. The SRU incorporates a built-in V.14 Async-to-sync converter to avoid over-sampling and consequently saves bandwidth. Asynchronous data circuits are converted to synchronous mode by the SRU card prior to multiplexing onto a WAN aggregate.

Subrate data ports are multiplexed into industry standard DSO formats. The user may specify the format of the DSO that the data port is assigned to. The choices are: (1) DSO-A which allows only one data port to be mapped into the DSO and (2) DSO-B which allows multiple data ports from multiple SRU cards in the system to be mapped into the same DSO time slot. If the DSO-B format is selected, then the user can specify the type of DSO-B format required (b-5, b-10 and b-20) and the sub-rate position that the data port will occupy within the DSO-B frame.

In b-5 mode, the DSO is divided into five sub-rate positions, each of which are occupied by a data port operating at 9.6 Kbps, 4.8 Kbps, or 2.4 Kbps. Additionally, one or two 19.2 Kbps circuits are supported in b-5 mode. Each would occupy two of the five sub-rate positions. Additionally, data circuits running at 28.8 Kbps or 38.4 Kbps are supported in b-5 mode and will occupy three or four of the five available sub-rate positions.

In b-10 mode, the DSO is divided into ten sub-rate positions, each of which are occupied by a data port operation at 4.8 Kbps or 2.4 Kbps.

In b-20 mode, the DSO is divided into 20 sub-rate positions, each of which are occupied by a data port operating at 2.4 Kbps.

In the application shown in Figure 4-5, the IAD with the SRU card (on the right hand side) can either send each sub-rate on a separate DS0 (DSO-A format) or groom multiple subrate channels into a single DS0 (one of the DSO-B formats).

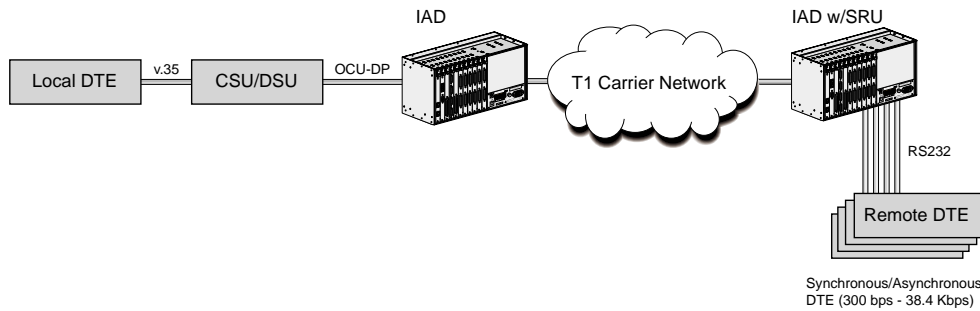

Figure 4-5.IAD with SRU Card Application

The SRU card also supports X.50 division 3, an ITU (CCITT) standard for sub-rate multiplexing. The maximum bandwidth of the SRU card is 115.2Kbps. The SRU card provides the ability for software configurable delay optimization. If delay optimization is used on all 10 ports, the maximum bandwidth available will be 76.8Kbps. Software-initiated diagnostics supported on the SRU card is the same as on the HSU card.

4.3.5 OCU-DP Card (8249, 824660 & 824760)

The OCU-DP (Office Channel Unit - Data Port) is used to interface directly to Data Service Units (DSUs)/Channels Service Units (CSUs) supporting data traffic up to and including 64Kbps. A four-wire circuit can connect the OCU-DP card to a DSU/CSU that can be located up to four miles away. In switched 56 Kbps mode, users can access the network on an as-needed basis by dial-up commands. The system unit must be equipped to provide -48 VDC power to fully support the functionality of the OCU-DP card.

4.3.5.1 OCU-DP Card Models

The Integrated Access System supports three cards for support of external CSU/DSUs that are stated below:

- 8249 OCU-DP 2 Port Card
- 824160 OCU-DP 5 Port Card
- 824660 OCU-DP 10 Port Card

All OCU-DP cards have RJ48 female connectors.

Each OCU-DP port can be independently programmed to operate at 2.4, 4.8, 9.6, 19.2, and 56 Kbps in either DS0-A, (one channel per DS0) or DS0-B format, which allows multiple data ports from multiple OCU-DP cards in the system to be mapped into the same DS0 time slot. If the DS0-B format is selected, then the user specifies the type of DS0-B format required (b-5, b-10 or b-20) and the sub-rate position that the data port occupied by the data port within the DS0-B frame.

In switched-56K mode, an OCU-DP port provides a connection for an external Switched-56K DSU/CSU that will perform all call set-up and dialing functions. The OCU-DP card converts the call set-up commands into standard signaling and sends the signaling over the WAN facility.

All OCU-DP cards support a low speed secondary channel that is established in the 8th bit position of the DS0 time slot to which the OCU-DP port is assigned. The secondary channel can be used for testing and maintenance of the main circuit or for the transmission of other, independent, low speed data. The specification table shows the secondary channel rates associated with the standard primary port rates of the OCU-DP card.

The 8249 OCU-DP card also supports two methods of error correction. The first is known as "Majority Vote" and applies to the lower data rates, specifically, 2.4, 4.8 and 9.6 Kbps. The other is known as the BCH (Bose-Chaudhuri-Hocquenghem) method and applies to data rates of 19.2 Kbps and 56 Kbps. In the case of a 19.2 Kbps circuit, the error correction information is placed in the same DS0 that the circuit occupies. In the case of a 56 Kbps circuit, the error correction information is placed in a following, adjacent DS0 time slot on the WAN aggregate.

On all OCU-DP cards' performance statistics is collected by the system and are available through the user interface. Performance statistics include Errored Seconds (any second with an error), Severely Errored Seconds (any second with an error rate exceeding $10E-3$) and Consecutive Severely Errored Seconds (CSES). They are displayed in hour intervals for up to 24 hours. CSES are counted by the system once ten consecutive Severely Errored Seconds are logged. The CSES counter stops if the system logs ten consecutive non-Severely Errored Seconds.

An OCU-DP port on the 8249 card may be programmed for OCU mode or CSU mode. OCU mode is the most common and is used whenever the OCU-DP port attaches to a CSU/DSU over a four-wire circuit. CSU mode allows the card to be connected directly to the digital network.

Software initiated diagnostics supported by the OCU-DP card include the setting of six different loop backs. Three of these act on the OCU-DP card itself and are known as local loop backs and the other three generate loop back patterns to remote devices and are known as remote loop backs. Among local loop backs, there are three types:

- loop backs of the 4-wire analog interface of the OCU-DP port towards the attached CSU
- loop backs of the 4-wire OCU-DP interface towards the network
- loop backs towards the network at the point where the OCU-DP card interfaces with the system bus

All three remote loop backs are latching loop backs. These latching loop backs are:

- loop back of the analog interface of the remote OCU-DP device back towards the network
- loop back of the 4-wire interface of the remote CSU device back towards the network
- loop backs of the 4-wire interface of the local CSU device towards the network.

An OCU-DP port may be programmed to detect and respond to both latching and non-latching (i.e., alternating) DDS-format OCU loop back codes that are initiated from the remote end of the circuit. A time-out option authorizes the OCU-DP port to automatically release the loop back after ten minutes.

4.3.6 DSO-DP Card (825460)

The 825460 DSO Data Port/G.703 Data Unit (DSO-DP/G.703) is a plug-in user card for the system. The DSO-DP/G.703 provides a 64 Kbps interface to a DSO of a T1/E1 network. The card supports four (4) ports each of which provide a 64 Kbps interface to a DSO on a T1 or E1 WAN link. Each DSO-DP/G.703 card can be installed in any User Slot and provides four (4) DB15 female connectors.

The DSO-DP/G.703 card can be programmed to operate in either DSO-DP mode or in G.703 mode. In G.703 mode, the card supports either co-directional or contra-directional operation and that option is set-able on a port-by-port basis. In DSO-DP mode, in addition to Transmit Data and Receive Data, the card can be programmed to either provide a 64 Kbps bit clock and an 8 kHz byte clock to the attached device or to receive those two clocks from the attached device.

In G.703 Co-Directional mode, the Transmit Data and Receive Data leads are supported. The clock information and the data make up a composite signal and the clock must be derived from the data stream. In G.703 Contra-Directional mode, the port provides separate Transmit and Receive Clocks to the attached device. Both clocks are 64 Kbps clocks with embedded 8 kHz Bipolar Violations (BPVs) to mark the byte boundaries.

Software-initiated diagnostics supported on the DSO-DP/G.703 card include the setting of local loop backs towards either the network or the attached DTE equipment. In addition, a remote loop back function allows the DSO-DP/G.703 card to generate four DDS-compatible latching loop back codes for the far-end OCU, CSU, DSU or DSO-DP equipment respectively. A time-out option authorizes the DSO-DP/G.703 port to automatically release the loop back after ten minutes.

4.4 ADPCM Voice Compression Server (887170)

The 887170 ADPCM (Adaptive Differential Pulse Code Modulation) server cards are designed to compress digital and analog voice traffic for transmission over wide area network links. The level of compression for an individual channel is software configurable at 24Kbps, 32Kbps or 40Kbps. A single ADPCM card is capable of compressing 64 channels of voice simultaneously. The 887170 card is a RoHS-compliant card, and utilizes different technology to accomplish the task for the ADPCM function. Both cards are identical in form and function, and can be used interchangeably.

Since the ADPCM card is a server card, these 64 channels can be originated from a variety of interfaces, including FXS, FXO, E&M, SRU, BRI, and T1/E1. Up to two ADPCM server cards can be supported per Integrated Access System for a total of 128 compressed voice channels. A third ADPCM server card can be utilized for 1:N redundancy.

The sum of the compression rates for the engine pair must equal 64Kbps. A 32Kbps circuit can only be paired with a 32Kbps circuit. A 40Kbps circuit can only be paired with a 24Kbps circuit and vice-versa. The ADPCM server card can also pair a low speed asynchronous data

transmission (19.2Kbps or less) from an SRU port with a 40kbps engine. This data path will occupy a 24Kbps engine. Group II FAX is supported in 32Kbps channels and Group III FAX is supported in 40Kbps channels.

Modem support up to 4.8Kbps, and V.32bis to 9.6Kbps is supported in 32Kbps channels. Modem speeds up to 12Kbps, and V.32bis speeds up to 14.4Kbps is supported in 40Kbps channels. Modem data is not supported in 24Kbps channels.

The ADPCM card supports Transition Signaling as defined by ANSI T1.302-1989 with the exception of the Alarm bits. ANSI T1.302 specifies signaling at the 32Kbps compression rate. The ADPCM card uses this scheme for 24Kbps and 40Kbps although it is not included in the standard.

The ADPCM card can be used in a variety of applications to reduce the number of transmission lines for efficient transport of voice traffic. It can be used in:

- PBX to PBX trunk application
- Automatic Call Distribution application
- Efficient wireless base station/hub application

4.4.1 PBX to PBX Trunk Application

Figure 4-6 shows the IAD with an ADPCM server used to compress two T1 or E1 PBX-to-PBX trunks into a single trunk. The voice from each PBX is connected via a digital T1 or E1 connection to the IAD. The voice channels are routed to the ADPCM server, where each voice channel is compressed to 32 Kbps. The compressed voice is routed to the outbound T1/E1 link to the other IAD unit, where it is decompressed and placed back into two T1 or E1 trunks to the remote PBX. PBX to PBX trunk lines can be compressed 2:1 to reduce leased line charges. The application is also valid for analog PBXs and key systems.

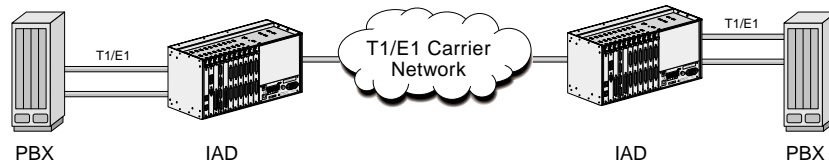

Figure 4-6. IAD using ADPCM for PBX to PBX Application

4.5 Management Channel Concentrator (MCC) Server (881360)

The Management Communications Concentrator (MCC) provides management connectivity to remote Integrated Access Systems. It can concentrate the TCP/IP management traffic from up to 131 remote IAD clients onto either a single, local 10 BASE-T Ethernet port, or encapsulate the information as per RFC1490 on to a Frame Relay link.

There can be up to 3 MCC server cards in an IAD chassis in non-redundant operation. The following hardware and firmware must be included in an IAD to add MCC Server operation:

- 880370 CPU Control Card with 8 T1/E1 Cross Connect (redundant-capable)
- 892260/892261/892360/892460 - 8 T1/E1 Interface card w/ 128K NVRAM.
- 881360 Advanced Communication Server (ACS) with 131 logical ports
- 60500 or above Host Firmware version
- 63130 - MCC Server firmware

The following protocols are supported by the MCC:

- Ethernet Media Access Control Protocol (MAC)
- Address Resolution Protocol (ARP)
- Internet Protocol, version 4. (IP)
- Internet Control Message Protocol (ICMP)
- User Datagram Protocol (UDP)
- Routing Information Protocol (RIP)
- Frame Relay (RFC1490)

The MCC provides management of remote IADs' using TCP/IP and SNMP/UDP/IP through the FDL bit of the ESF format if used for T1. For E1, management is provided through the SA4 bit of the frame following the frame alignment word in time-slot 0. The MCC offers far more interfaces and functionality than the B7R, thus replacing it, and the device used to route between the asynchronous aggregate serial port and Ethernet.

MCC can be configured to use unnumbered or numbered interfaces. If unnumbered interfaces are used, MCC is accessed through the global Ethernet address regardless of what interface is used. If numbered interfaces are used, each interface has a local IP address. Unnumbered interfaces help conserving IP addresses as only one address is used per interface. This addressing method may not be compatible with HP Openview.

The MCC routes IP datagrams between all of its interfaces, based on each datagram's IP destination address.

Datagrams are directed (or routed) to the interface carrying the sub-net to which the datagram belongs or is being transported to, according to the content of the routing table. The routing table may be supplied with dynamic routes from the Routing Information Protocol (RIP) when enabled. If no match is found in the routing table, a default route can be designated to direct all unresolved datagrams to a specific interface.

Initial configuration of the MCC can be made through the local VT100 port. When a working interface is established to the CPU hosting the MCC, subsequent configurations can be done remotely via SNMP/TELNET. All configurable port parameters are permanently stored in NV-RAM and downloaded to the card during startup. An interface card remains in standby position until correctly configured and activated. Statistics are also available on both interface cards.

IP-based management information from clients is typically provided to the MCC by a Digital Access and Cross-connect System (DACS) as Bit Seven Redundant (B7R) or Bit Four Redundant (B4R) DS0 channels on a T1 or E1 link. The MCC routes IP packets among the 131 available WAN interfaces, the local host CPU and Ethernet. Each interface represents a separate network or subnet as specified by the IP address and Netmask combination. Three of the 131 are high-speed interfaces that can either be configured as $N \times 64$ kbps ($N=1$ to 24 for T1 or 1 to 31 for E1). Those interfaces can independently be configured for the Frame Relay protocol or for transparent HDLC. The 128 lower-speed WAN interfaces can be configured in groups of 64, to either be in BnR mode or plain 64 kbps. HDLC mode.

Figure 4-7 shows FDL channels from the remote IADs fed into a DACS II for translation into multiple B7R encoded DS0 channels. IAD I, connected to the DACS II, routes IP datagrams to IAD II through the alternative high-speed interfaces. IAD II in turn routes datagrams to the Local Ethernet to the NMS.

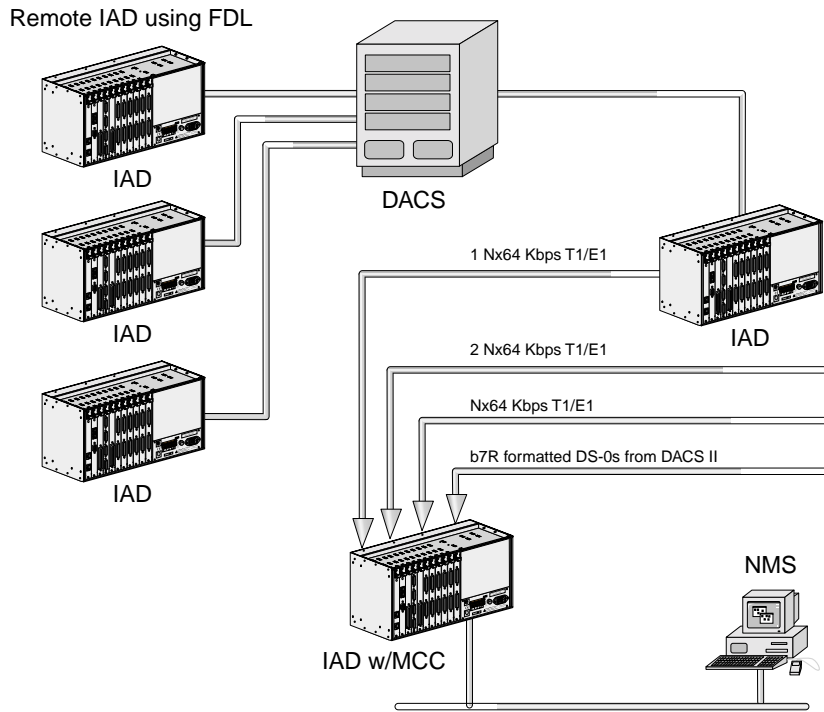

Figure 4-7. MCC Card in a Multilevel Concentration Application

The MCC card performance figure of 3500 packets/second was obtained using 64 byte packets. This implies that for small frames the processor is the bottleneck since the network link cannot be saturated. As the frame size increases, network link utilization becomes higher. For large frames, the network link will become saturated and hence the bottleneck. An equilibrium is reached at frame size of 500 bytes when both the processor and links are saturated.

4.6 Routing Server

The IP Routing Server enables the Integrated Access System to act as a gateway router to the Internet via bundled service deployment or in private Intranet network deployment. Specifically, the primary market for the IP Routing Server is Internet access via bundled service arrangements (integrated access). The bundled service marketplace is simply the provisioning of multiple services over a single T1 or E1 to a customer. Typical bundled service arrangements include local voice service, long distance service and a data service. Internet access is one of the possible data services. The potential market for this technology is quite

extensive. There are over 6.5 million small business in the US, and about 1.3 million of these have 6 to 20 phone lines. These businesses are prime candidates for bundled service arrangements. Carriers are aggressively targeting this market, as they strive to out position one another with integrated business telecommunications solutions.

The Integrated Access System platform is unique in that it possesses many of the qualities listed below in a flexible form factor. As equipment and technologies mature, there is a constant requirement to consolidate communications equipment for many reasons, including:

- lower capital costs
- integrated management
- ease of use and installation
- remote connection efficiency

4.6.1 Bundled Service Deployment

The IP Routing Server is targeted at performing boundary routing functions for access to Internet or Intranet based services. The standard application for an IAD in this environment is in bundled service arrangements where the IAD is utilized to integrate voice circuits and an Ethernet-based Internet port at the customer location as shown in Figure 4-8. The carrier would typically switch the voice circuits to the PSTN via a DACS, while the frame relay based data connection from the Ethernet port would be connected to a Frame Relay network for transmission to the Internet. An external firewall can be used for providing and maintaining security when connected to the Internet.

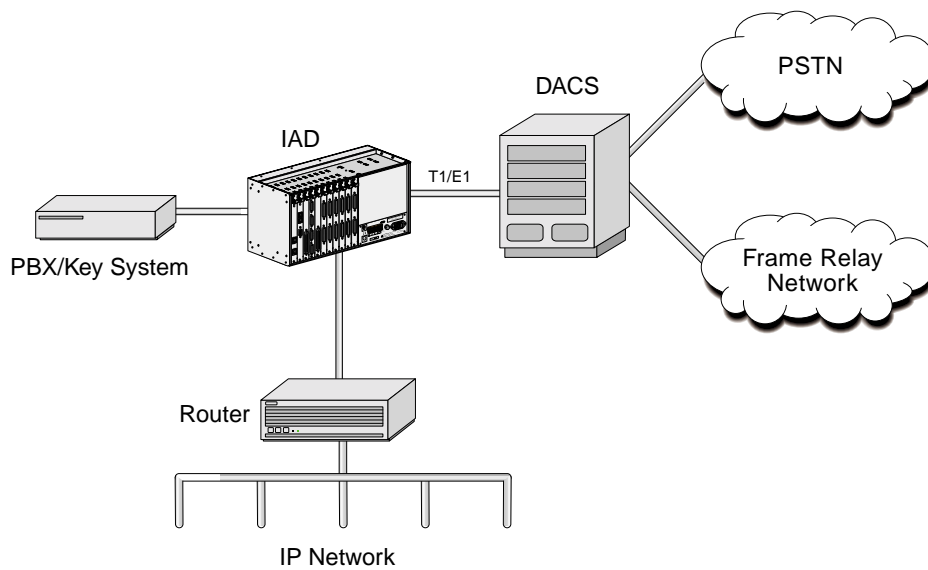

Figure 4-8. IP Routing Server for Internet or Intranet Based Services

4.6.2 Private Intranet Deployment

A secondary market for the IP Routing Server is private Intranet access. In the application shown in Figure 4-9, remote site A is connected to a private WAN. The remote site has a single connection to a centralized router, which provides full IP routing functionality. The IAD on the right has two T1 connections, one to each of the two remote IAD, and one connection to the router. Normally, there would be two connections to the router. However, in this application, the IAD on the right includes a Frame Relay Server card which switches both frame relay streams into the router.

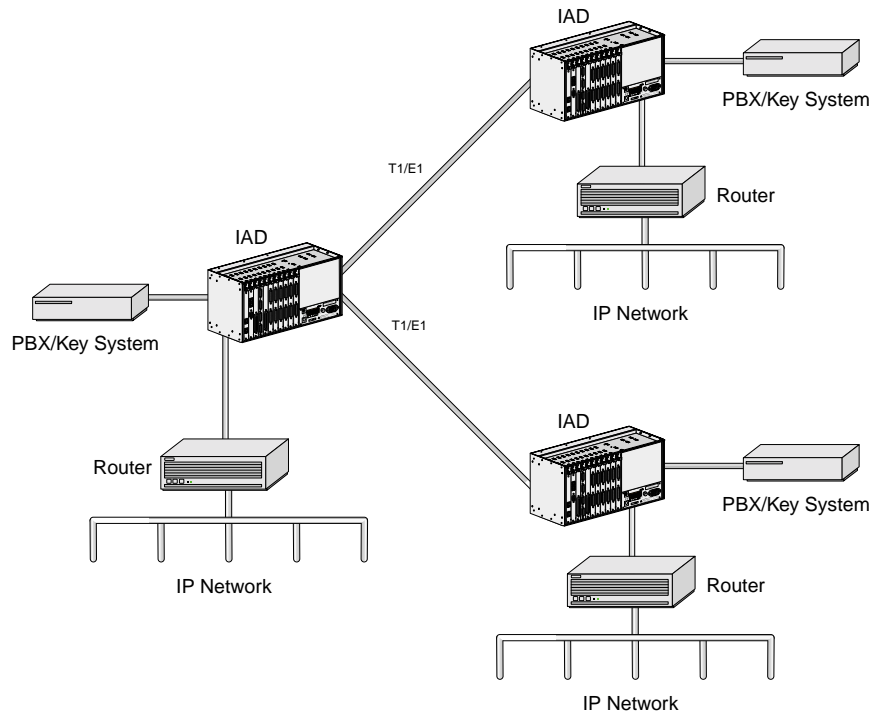

Figure 4-9. Private Intranet Deployment using IP Routing Server Card

4.6.3 IP Routing Server Specifications

Up to three IP Routing server cards can be functional in an Integrated Access System in a non-redundant configuration. The processor performance figure of 3500 packets/second was obtained using 64 byte packets. The following hardware and firmware must be included in an Integrated Access System to add IP Server operation:

- 880370 - CPU Control Card with 8 T1/E1 Cross Connect (redundant-capable)
- 892360/892460 - 8 T1/E1 Interface card w/ 128K NVRAM
- 881161- Advanced Communication Server (ACS) with 3 WAN ports
- 60500 or above Host Firmware version (831060 requires 60520 Host firmware)
- 67110 - IP Routing Server firmware

Chapter 5

System Configuration and Operation

5.1 Basic Operations

This chapter provides instructions for configuring the Integrated Access System for operation after installing it at the equipment site.

Before performing the procedures in this chapter:

1. Be sure your Integrated Access System is installed and powered up.
2. Determine your system's specific configuration requirements. These depend on your network and customer premises equipment (CPE) interfaces. If this configuration information already exists, obtain it from your system administrator or engineers.
3. Obtain a terminal with VT-100 or VT-102 emulation and an RS-232 to RJ48 cable for these procedures. The terminal will be connected directly to the TERM port on the Interface card in your system. It allows you to access the system and then configure it for operation with your network and CPE.



WARNING! During system operation it may be necessary to remove and replace certain circuit packs, either as a maintenance procedure or to restore service should a circuit pack fail. All circuit packs are "hot swappable". This means that they can be removed and inserted while the system is powered and providing service, and no physical damage will be caused to the circuit pack or the system. However, all circuit packs do share the same backplane and data busses. As with any bus based architecture, there is a possibility that removal and installation of a card could cause a momentary service degradation to other cards on the same bus. This degradation would typically be seen as a few data errors on other active data circuits on the same bus. The higher the speed of the data circuit, the more susceptible it would be to this type of interruption. Voice cards are typically not affected by such brief error bursts. Therefore, in order to minimize the possibility of data errors during a circuit card hot swap, Zhone recommends that maintenance procedures on the IMACS be done during periods of

low system activity or during the maintenance window whenever possible.

5.2 Basic Screen Map and Legend

To make system access, configuration and testing easy, the system presents you with a series of user interface screens. Each screen displays various fields of information, and you can change the data in those fields as required by your system and external interfaces.

5.3 System Initialization

System initialization consists of registering your system then logging into it for additional configuration. These operations are described on the following pages.

5.3.1 Registration

To register your system after starting it up for the first time, proceed as follows:

1. Be sure your system and local terminal are both powered up.
2. Connect a VT100-compatible terminal to the TERM jack on the Interface card front panel. Use a cable with an RJ-48 modular plug on one end for this connection.
3. Configure the terminal to operate at 9.6 kbps, 8 data bits, no parity, and 1 stop bit.
4. Press the RETURN key. The Registration Screen in Figure 5-1 appears.

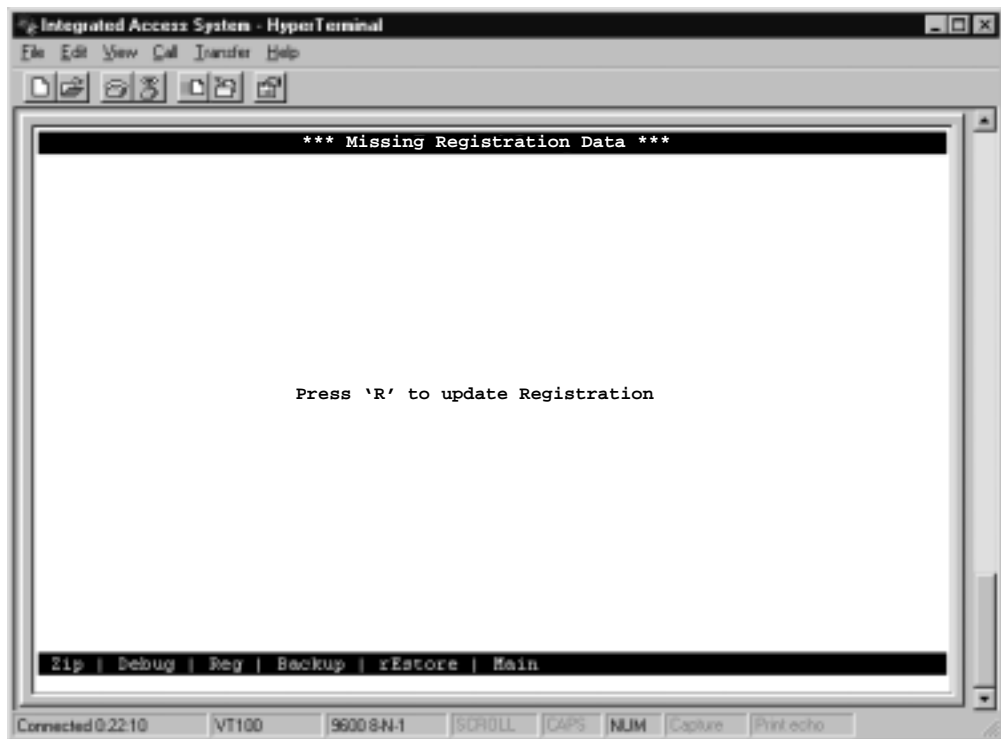

Figure 5-1. First Time Registration Screen

5. Press "R" to update Registration.

6. Enter password as shown in Figure 5-2. Refer to Table 5-2 on page 5-11 for default passwords and access level, press the <Enter> key.

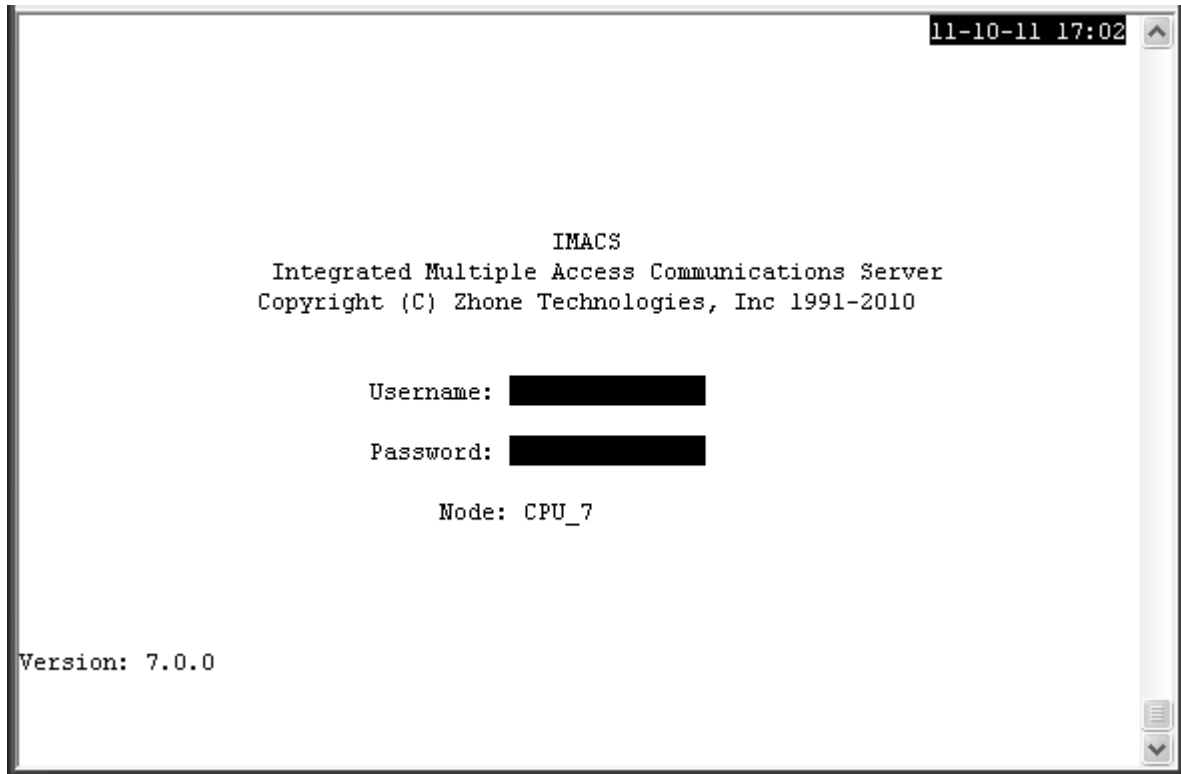

Figure 5-2. First Time Login Screen

7. Enter your vendor code in the Vendor Code field. See Figure 5-3 below, press the <Enter> key.



Figure 5-3. Welcome to Registration Screen

The Vendor Code for this Integrated Access System is given in a registration sheet that is usually in a plastic bag attached to the Power Supply Cover panel.

8. Select the type of chassis used (front-loading with power supplies on the side, front-loading with power supplies on top, or front/rear loading with power supplies on the side).
9. If the vendor code and chassis types selection are both correct, type **Y** to confirm and save that data. Otherwise, type **N** to return to the screen for changes.

The system now automatically restarts with the correct application parameters. Proceed to the next section, log into the system, and start configuring it for operation.

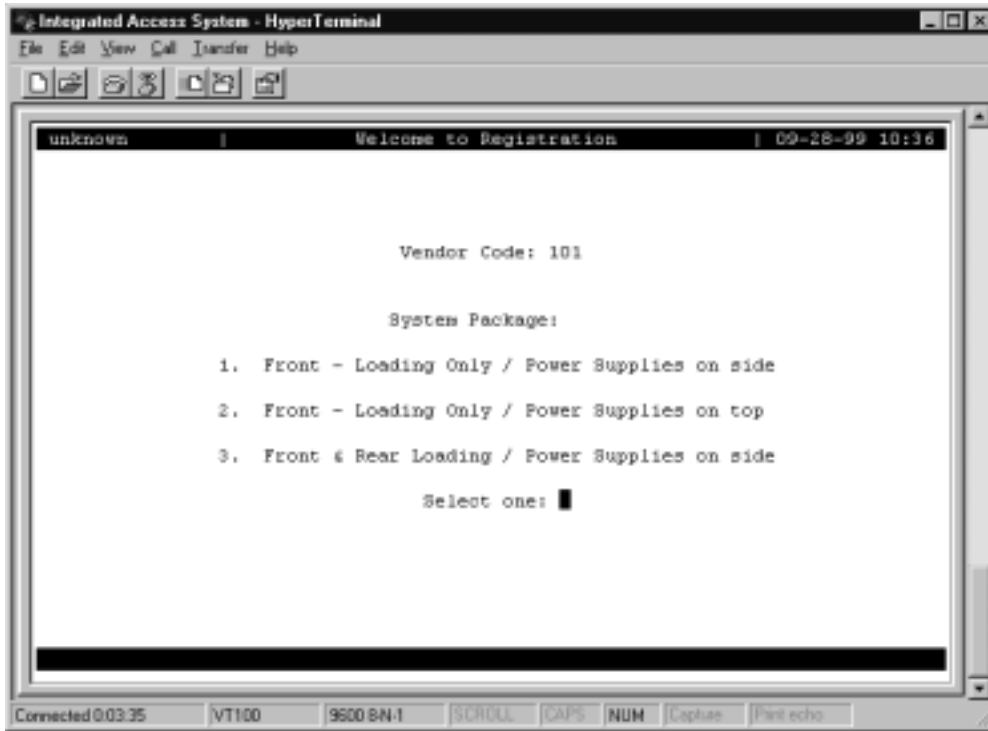

Figure 5-4. Selecting Chassis Type Screen

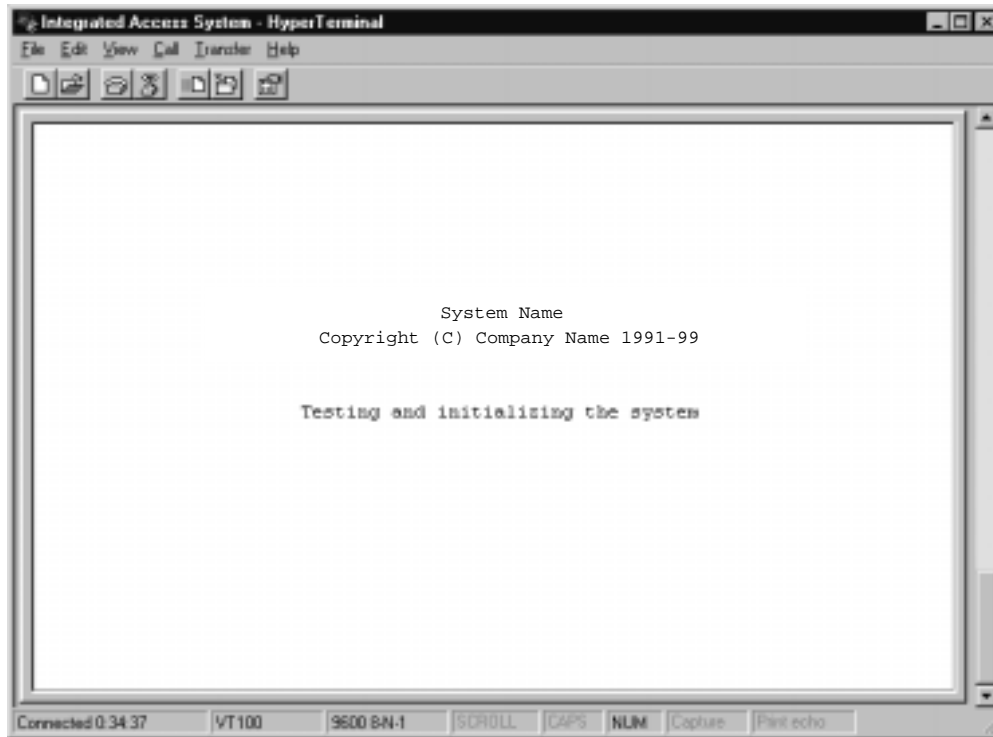

Figure 5-5. Testing and Initialization Screen

The system will display the “Testing and Initializing the System” screen in Figure 5-5 above. When testing and initializing is complete the screen will go blank. Press the <Enter> key. The System Login Screen will display. See Figure 5-6.

5.3.2 Logging Into the System

The first step in starting an operator session is to log into the system. You must enter a username and password that allows you to perform the required tasks on the system. The initial (default) login information corresponds to one of four different access levels, each allowing you to perform certain tasks. The only provided default username and password is admin / admin as shown in Table 5-2 on page 5-11. Table 5-3 on page 5-12 lists the default privileges for each access level that can be assigned.

All usernames and passwords are case-sensitive for maximum security. For example, the system handles the usernames **TechMan**, **TECHMAN**, and **Techman** as three different entries.

To log into the system from a local terminal, proceed as follows. To log in from a remote PC refer to details later in this reference manual.

1. Press <Enter>. The Login Screen depicted in Figure 5-6 should appear. If not, press <Enter> repeatedly until it does.
2. If the Login Screen does not appear after you press <Enter> several times, check your terminal settings (they should be 9.6 kbps, eight data bits, no parity, and one stop bit)

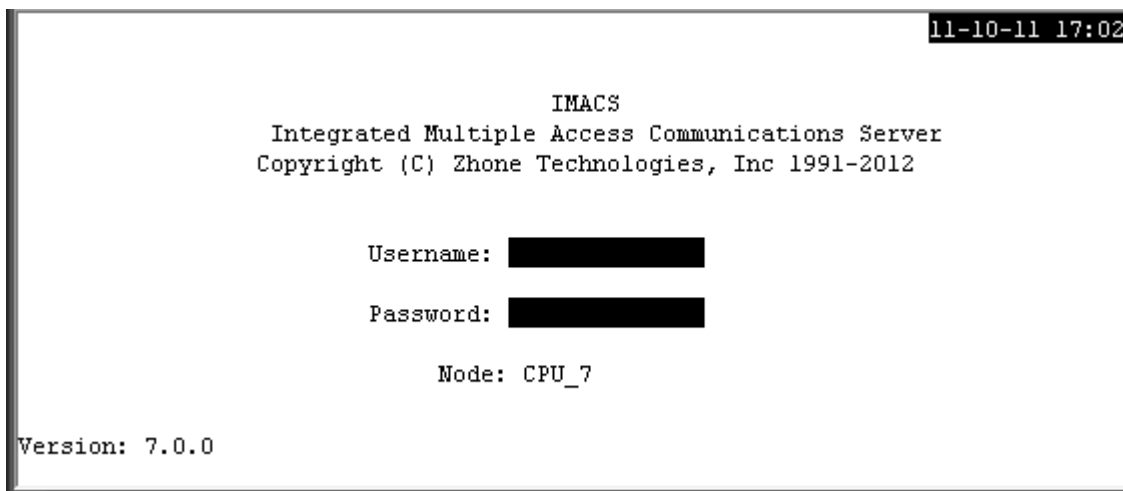

Figure 5-6. Typical Login Screen

3. Contact your system administrator for your username and Password. Enter your username and password. Then, press RETURN to accept the information, which will allow you to configure your system after logging in for the very first time. Refer to the next section for descriptions of the various operator password levels.

4. A System Main Screen appears. Figure 5-7 shows this screen for a two-sided chassis and a front-loading chassis with power supplies on top. Figure 5-8 shows a similar screen for a front-loading chassis with power supplies on the side. Refer to the next section for a discussion of the Integrated Access System's user interface screen hierarchy.

This completes the login process. If you are not familiar with the user interface screens of the system, read the next section before proceeding. Otherwise, continue with the desired operation.

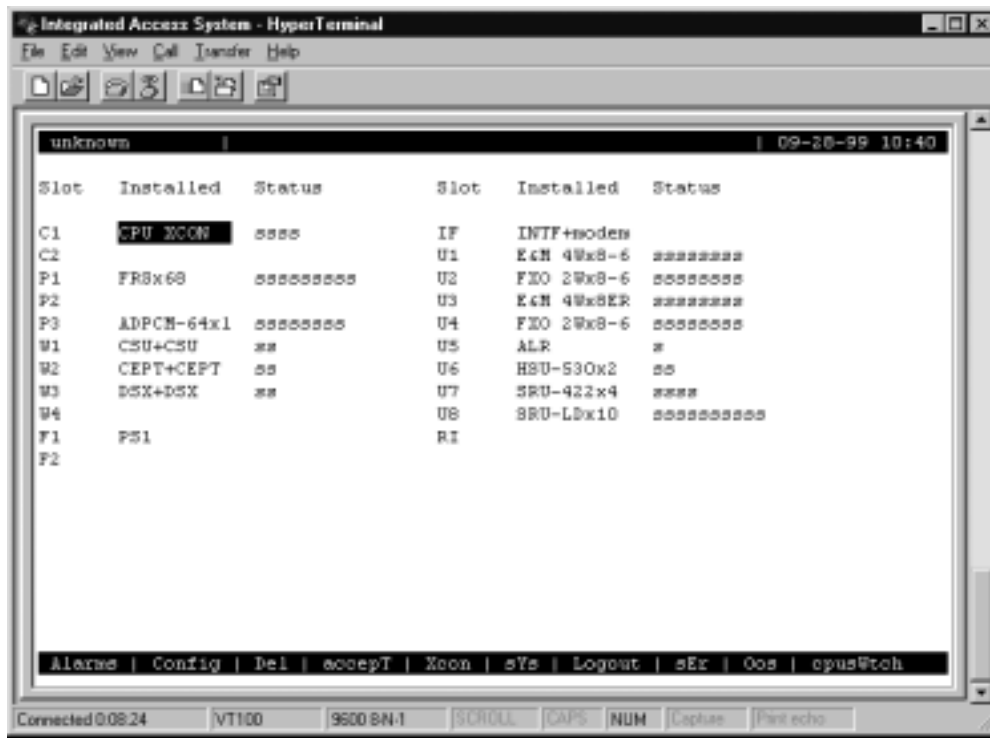

Figure 5-7. Main Screen (Two-Sided and Front-Loading Chassis - Power Supplies on Top)

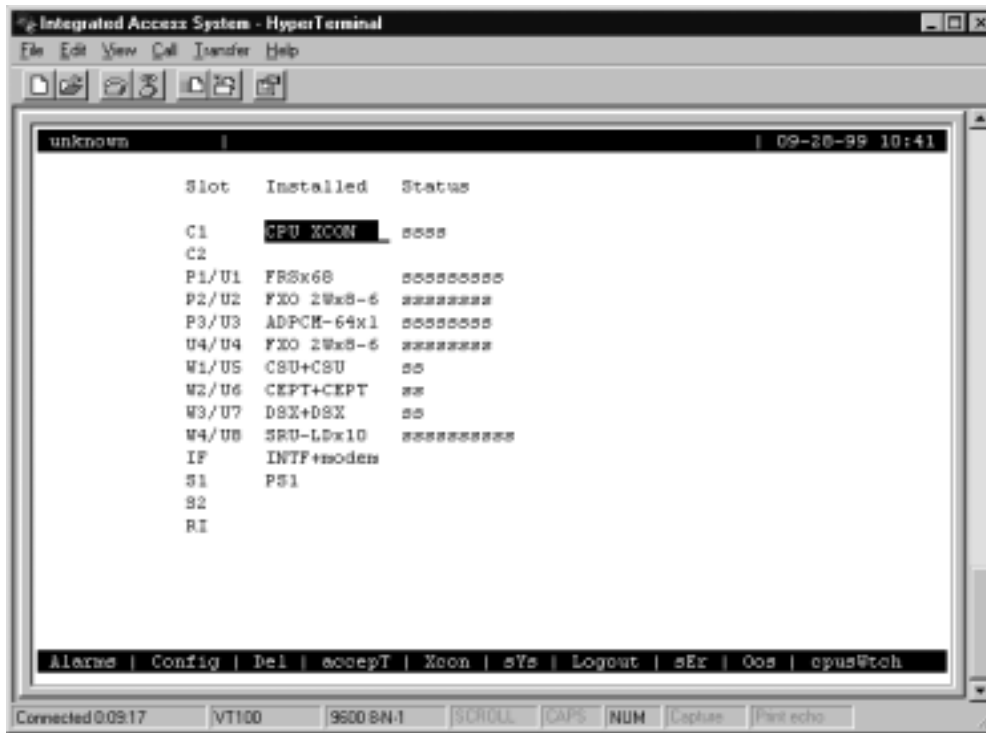

Figure 5-8. Main Screen (Front-Loading Chassis Power Supplies on the Side)

5.3.3 User Names, Passwords and Groups

Our customers now have the ability to use RADIUS to manage their login privileges. With the RADIUS feature active, the usernames and password verification on the local IMACS is ignored, unless fallback is enabled AND the server is not reachable.

You may want to change your system access passwords frequently, in order to maintain optimum security on your network. The recommended passwords are a minimum of 6 and no more than 12 characters in length, are not found in a dictionary, and contain both letters and numbers. Because the system is case-sensitive for password entries, you can mix uppercase and lowercase letters to provide more possible passwords.

The user administration function is activated by entering 'n' for usrNames from the CPU screen, as shown in Figure 5-9.



Note: The passwords **MUST** be at least six characters long and **MUST** be a combination of characters and at least one digit!

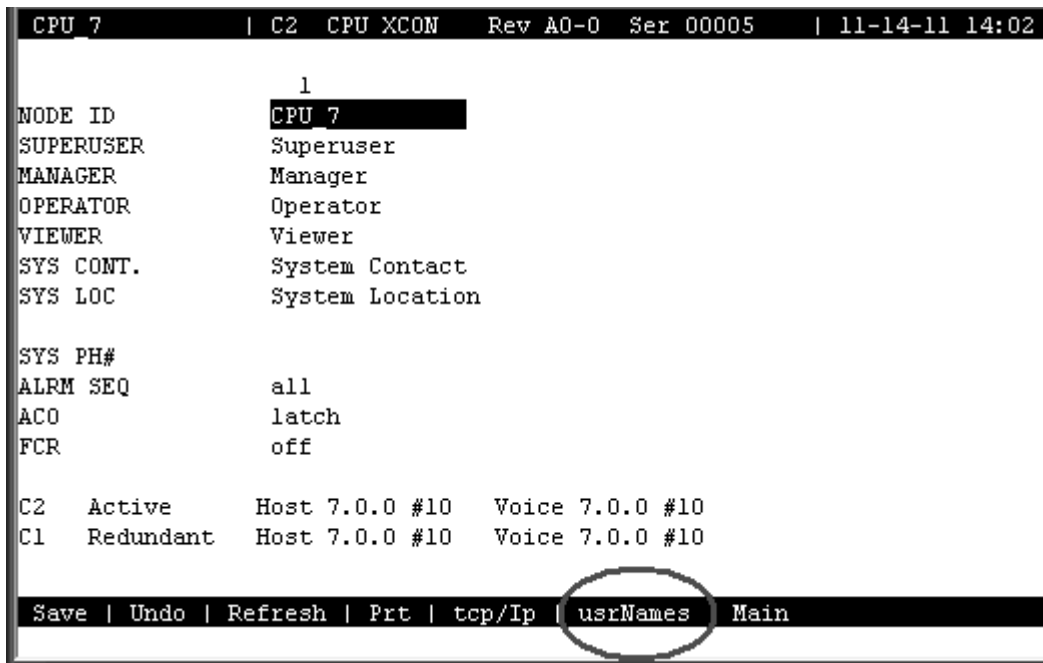

Figure 5-9. CPU screen - usrNames option

The system supports 256 possible users. Each user is defined by the use of three entries or fields. The fields are editable by a user who has Administrator or Superuser access. Following is a brief description to the user fields:

Table 5-1. User Access Table

User Name	Password	User Group
An Alpha-numeric string consisting of 6 to 12 characters. Duplicate user names are not allowed, i.e. all 256 user names must be unique.	An Alpha-numeric string consisting of 6 to 12 characters.	A number from 1 to 32.

When the system is first commissioned, there is only one group defined:

Table 5-2. Default User Table

Default User Name	Default Password	Default User Group
admin	admin	1

Each user group represents a different access level that allows a login ID to perform certain system tasks after logging in.

5.3.3.1 User Groups

The User Group that is assigned to a user defines the access level that he or she has to various system functions. The following example shows a portion of a user group provisioning table. The system allows for 32 such user groups:

Table 5-3. User Accesses by Group

<u>User Group Number</u>	<u>WAN Provisioning</u>	<u>WAN Alarms</u>	<u>WAN PMs</u>	<u>Access Provisioning</u>	<u>Access Alarms</u>	<u>Access PMs</u>	<u>Administer System</u>	<u>Administer Users</u>
1 (Superuser)	RW	RW	RW	RW	RW	RW	RW	RW
2	N or R or RW	N or R or RW	N or R or RW	N or R or RW	N or R or RW	N or R or RW	N or R or RW	N or R or RW
3	N or R or RW	N or R or RW	N or R or RW	N or R or RW	N or R or RW	N or R or RW	N or R or RW	N or R or RW
4	N or R or RW	N or R or RW	N or R or RW	N or R or RW	N or R or RW	N or R or RW	N or R or RW	N or R or RW
n	N or R or RW	N or R or RW	N or R or RW	N or R or RW	N or R or RW	N or R or RW	N or R or RW	N or R or RW
n	N or R or RW	N or R or RW	N or R or RW	N or R or RW	N or R or RW	N or R or RW	N or R or RW	N or R or RW
32	N or R or RW	N or R or RW	N or R or RW	N or R or RW	N or R or RW	N or R or RW	N or R or RW	N or R or RW

When the system is first commissioned, or after a ZIP function, the user group defaults to the following configuration:

Table 5-4. Default Group Permissions

<u>User Group Number</u>	<u>WAN Provisioning</u>	<u>WAN Alarms</u>	<u>WAN PMs</u>	<u>Access Provisioning</u>	<u>Access Alarms</u>	<u>Access PMs</u>	<u>Administer System</u>	<u>Administer Users</u>
1	RW	RW	RW	RW	RW	RW	RW	RW
2 - 32	R	R	R	R	R	R	R	R

User group 1 is the "Superuser" and its attributes are not provisionable. User groups 2 to 32 default to R in all attributes. They can have any one of 3 possible values entered into the various cells of the user group table:

N = None. When "N" is entered in a section of the user group definition, users with that group have no access to that part of the system, including its UI

R = Read Only. When "R" is entered in a section of the user group definition, users with that group have read (or view) access to that part of the system, including its UI. However, they can not make any changes or edits.

RW = Read/Write access (full access). When "RW" is entered in a section of the user group definition, users with that group have read, write, and edit access to that part of the system, including its UI



WARNING! It should be noted that users with the ability to Administer Users will be able create new accounts with read/write access to ALL categories. Care should be exercised in providing access to the Administer Users function.

To change a password, first log into the system under a user who has the RW capability assigned to Administer Users, or the **admin** level. Enter the CPU level, as shown in Figure 5-9. Enter N for userNames, and a screen such as Figure 5-10 appears.



The screenshot shows a terminal window with a header bar containing system information: CPU 7, C2 CPU XCOM, Rev A0-0, Ser 00005, and 11-14-11 15:24. Below the header, it displays 'page: 1 of 1' and 'USER ADMIN'. A table lists users with their names, passwords (masked with asterisks), and user groups. The 'Craftsperson' user is highlighted. At the bottom, a navigation bar includes options: Refresh, Add, dE1, Group, Login log, pgUp, pgDn, and Main.

User Name	User Password	User Group
Craftsperson	*****	32
admin	*****	1

Figure 5-10.User Name Screen

Table 5-5 shows the valid actions that a user can perform when at the user name field.

Table 5-5. usrName Screen Actions

Action	Function
Refresh	Re-paints the current screen
Add	Allows you to add a user
Del	Allows you to delete a user
Group	Displays the Group settings and access level permissions as explained in Section 5.3.4 on page 18.
Login Log	Provides the last 20 login and logout events.
pgup	Pages up
pgdn	Pages down.
Main	Returns you to the CPU Main Screen. If you made changes to any port settings but did not save them yet, you will be prompted to save or lose those changes before exiting.

Refresh

Selecting ‘R’ for refresh will renew the data presented on the screen.

Add

To add a user, choose the **A** function. Use carriage returns to update a field, and arrow keys to move around in the screen. For Figure 5-11 below, the administrator chose Add, carriage return, typed in “Pastel” and return, right arrow, return, typed “flood01” and carriage return,

confirmed the password by typing in “flood01” a second time and carriage return, right arrow to the group field, carriage return and then used the up arrow until ‘06’ appeared and hit carriage return. Don’t forget to save your changes!

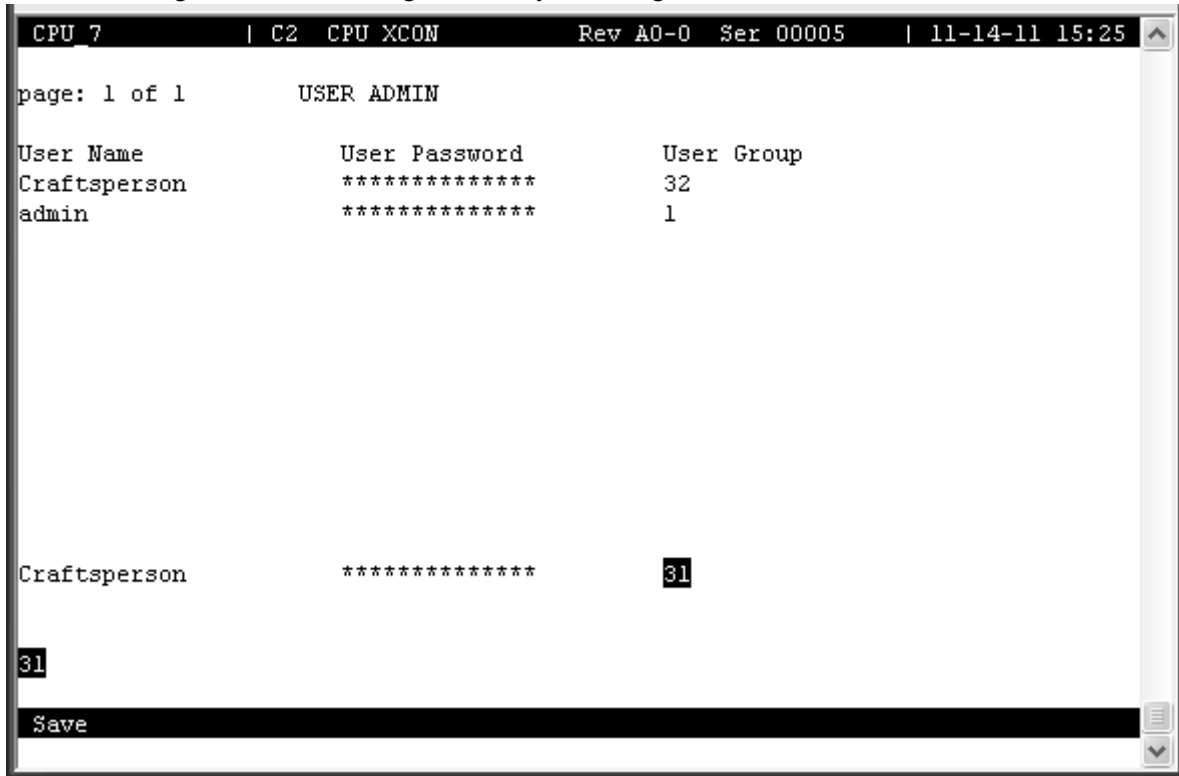

Figure 5-11.Adding a User

Del

Selecting the ‘E’ delete function will allow the user to delete the user that the cursor is currently positioned upon.

Group

Selecting ‘G’ will show the permissions for access to a Superuser that can be changed. These are outlined in Section 5.3.4 on page 18.

Login Log

Selecting 'L' will take the user to a screen where the login log is stored. This table is read-only, and will display the last twenty login and logout events. Figure 5-12 shows how a typical entry will appear.

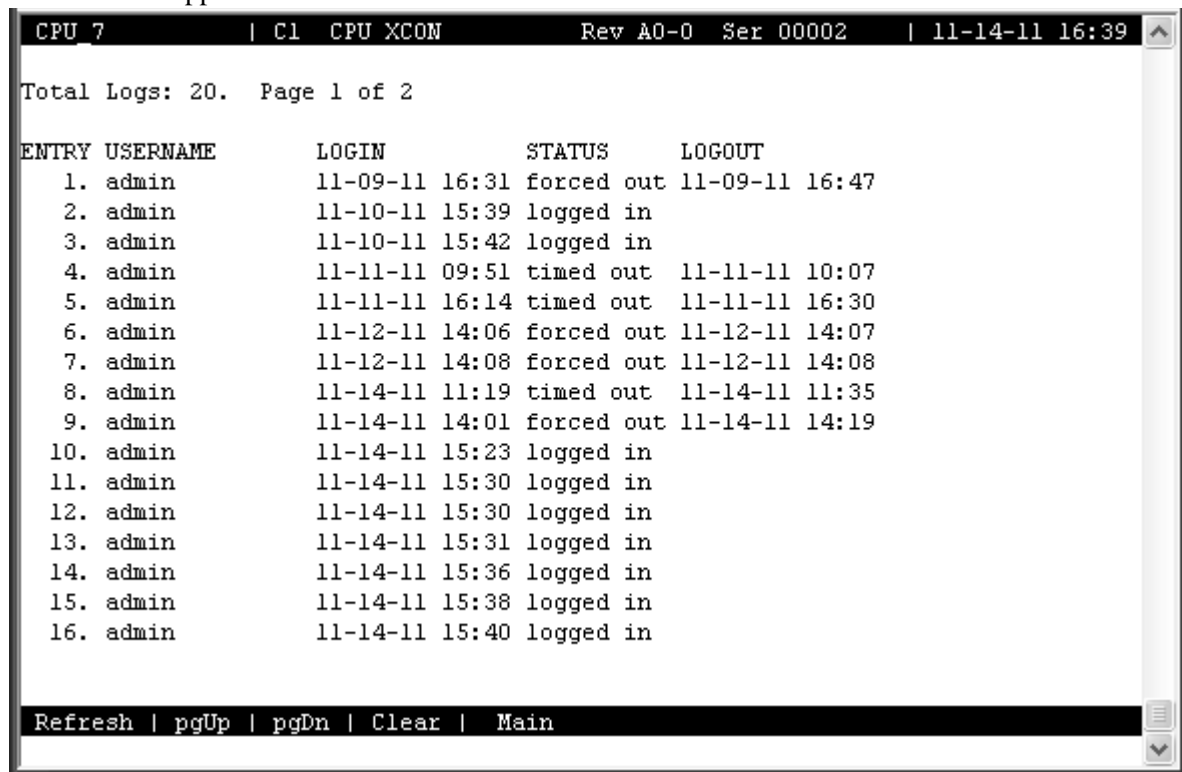

```

CPU 7 | C1 CPU XCOM Rev A0-0 Ser 00002 | 11-14-11 16:39
Total Logs: 20. Page 1 of 2
ENTRY USERNAME LOGIN STATUS LOGOUT
1. admin 11-09-11 16:31 forced out 11-09-11 16:47
2. admin 11-10-11 15:39 logged in
3. admin 11-10-11 15:42 logged in
4. admin 11-11-11 09:51 timed out 11-11-11 10:07
5. admin 11-11-11 16:14 timed out 11-11-11 16:30
6. admin 11-12-11 14:06 forced out 11-12-11 14:07
7. admin 11-12-11 14:08 forced out 11-12-11 14:08
8. admin 11-14-11 11:19 timed out 11-14-11 11:35
9. admin 11-14-11 14:01 forced out 11-14-11 14:19
10. admin 11-14-11 15:23 logged in
11. admin 11-14-11 15:30 logged in
12. admin 11-14-11 15:30 logged in
13. admin 11-14-11 15:31 logged in
14. admin 11-14-11 15:36 logged in
15. admin 11-14-11 15:38 logged in
16. admin 11-14-11 15:40 logged in
Refresh | pgUp | pgDn | Clear | Main

```

Figure 5-12. Login Log Sample Display

Login logs without the corresponding logout or forceout indicate a restart event, whether a switch of activity, power cycle or other such restart event.

Starting in CPU load 7.2.1, alarm events are also sent to the Syslog server. See “SYSLOG” starting on page 7-26 for more information regarding the syslog server.

pgUp

Selecting the 'U' function will cause the screen to page up, if applicable.

pgDn

Selecting the 'D' function will cause the screen to page down, if applicable.

Main

Selecting the 'M' function will return the user back one level to the CPU Main Screen.

5.3.4 Access Level Permissions

With the Admin level user, the Group setting can be changed on a group basis. Begin by accessing the User Name Screen as shown in Figure 5-10 on page 5-14. Select the Group option by typing "G", and a screen such as in Figure 5-13 appears

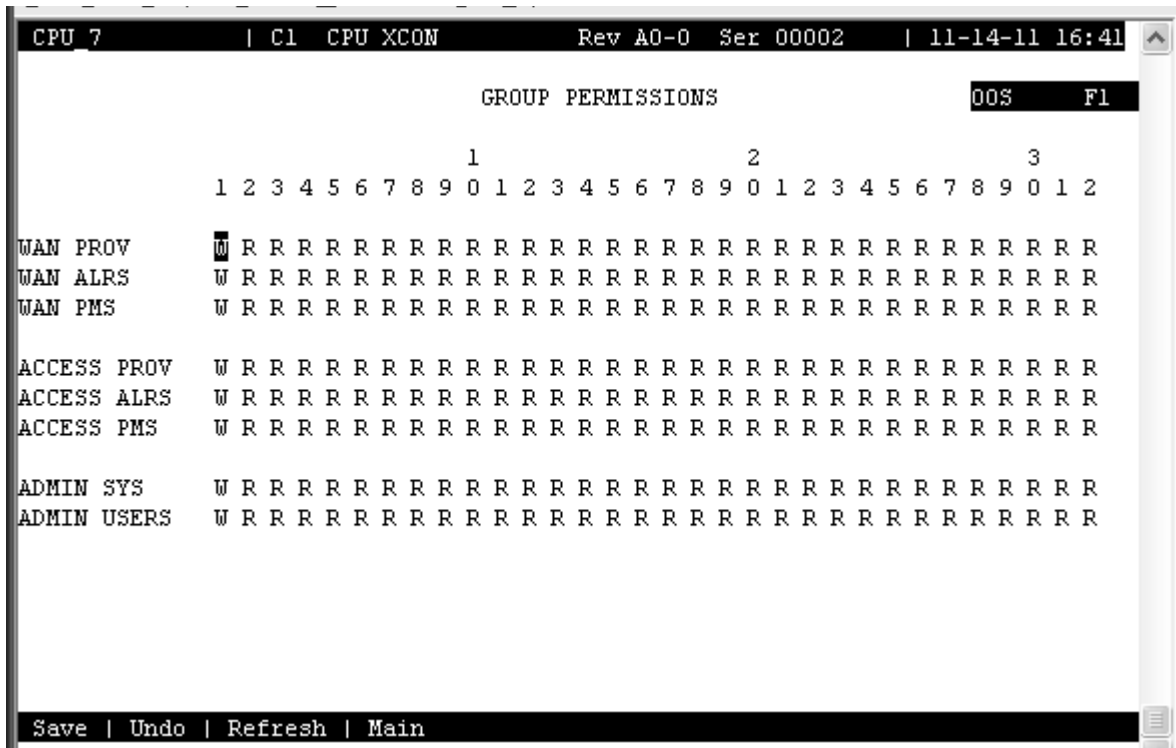

Figure 5-13.Group Permissions Settings

Use the arrow keys to select the field and permission that you want to change, and access the write capability by issuing a carriage return. The user can then set the access level to **N**one, **R**ead only or **R**ead **W**rite (**W**) as desired. Following is the description of the Access Levels, and what can be done in each.

WAN Provisioning

This covers all provisioning screens and activities associated with both the copper and optical WAN interfaces.

WAN Alarms

This covers all alarm reporting screens and activities associated with both the copper and optical WAN interfaces. Read access allows alarms to be viewed only. RW access allows changes to severity, thresholds etc. (any provisionable alarm attributes)

WAN PMs

This covers all performance monitoring screens and activities associated with both the copper and optical WAN interfaces. Read access allows PMs to be viewed only. RW access allows changes to intervals, thresholds etc. (any provisionable PM attributes)

Access Provisioning

This covers all provisioning screens and activities associated with all the access interfaces. This includes OHSU, HSU, SRU, voice, alarm, and Ethernet posts

Access Alarms

This covers all alarm reporting screens and activities associated with all the access interfaces. This includes OHSU, HSU, SRU, voice, alarm, and Ethernet posts. Read access allows alarms to be viewed only. RW access allows changes to severity, thresholds etc. (any provisionable alarm attributes)

Access PMs

This covers all performance monitoring screens and activities associated with OHSU, HSU, SRU, voice, alarm, and Ethernet interfaces. Read access allows PMs to be viewed only. RW access allows changes to intervals, thresholds etc. (any provisionable PM attributes)

Administer System

This covers system level activities such as IP addresses, inventory, software upgrade, data base backup, setting the real time clock, setting sync sources etc.

Administer Users

This covers the provisioning and administration of users and user groups. Read access allows user names and user group attributes to be viewed but not changed. RW access allows you to edit user names, passwords, and user group attributes. It also allows you to disable all users (ref. R-5.6.3.4 #5). You can never view passwords, even with RW access (ref R-5.6.3.1 #2). Users, once logged in, can always change their own password regardless of the attribute of this field in their user's group.

5.4 System Screens

The system screen will display each card that is currently installed onto the system along with the card status and location.

5.4.1 System Main Screen

After you log in, a System Main Screen similar to Figure 5-7 or Figure 5-8 appears, showing all of the cards currently in the system. The chassis slot locations, card types, and current card operational states also appear in this screen.

The highlighted line at the bottom of the screen lists some actions. Press the letter key that corresponds to the desired action you want to perform. For example, to go to the Alarms Screen (**Alarms** action) and see the current system alarms, press “**a**” (**can be typed in either uppercase or lowercase**). Table 5-6 summarizes the System Main Screen actions.

Table 5-6. System Main Screen Actions

Action	Function
Alarms	Brings up the Alarm Screen. Refer to "Alarms and Alarm Filters" later in this chapter.
Config	Sets up the system using a standard configuration.
Del	Removes an out-of-service (OOS) card from system memory.
accepT	Removes the current card settings. Used when replacing a card in any slot with a different kind of card.
Xcon	Brings up the cross-connect screens.
sYs	Brings up the system screen for high-level system testing and maintenance.
Logout	Logs you off the system.
sEr	Allows the operator to serialize a card on the shelf
Oos	Allows authorized operators to take cards out of service.
cpusWtch	Switches from the active CPU card to the redundant CPU card, if the system is configured for CPU redundancy.

5.4.2 CPU Card Status

The CPU card status will display **s** (standby) when a CPU card is properly inserted into slot C1 or C2 for all chassis types. The CPU card status will display **a** (active) when router ports C1, C2, C3 or C4 are set to active mode from the nx64 screen. For further explanation on how to set router port parameters, please refer to the nx64 section located in the CPU card chapter in this System Reference Guide.

5.4.3 Power Supplies and Ringing Generators Card Status

The power supply status will display PS1 when a power supply is properly inserted into slot F1 or F2 for the front-loading chassis with power supplies on top and the front & rear loading chassis with power supplies on side. For the front-loading chassis with power supplies on side, the status will display PS1 when properly inserted into slot S1. The ringing generator(s) will display RINGER next to the slot indicator RI on all chassis types. When the 8906 ring generator is used as a slave, only the master will show on the main page screen. The 8905 AC to DC power converter, if used on the IMACS shelf, will not display on the main page screen.

For a description of the power supplies and Ring generators, See “Power Supplies and Ringing Generators” starting on page 2-8

5.4.4 Voice and Data Card Status

The System Main Screen also displays the status of the individual circuit ports of all WAN, Voice and Data cards in the system. This information appears next to the card type, as shown in Figure 5-14. The lowercase letters in the Status column fields indicate the states of the individual card ports. The possible values for each port are s (Standby), a (Active), t (Test), l (currently in a Loopback state), and r (on a Redundant WAN or ADPCM card).

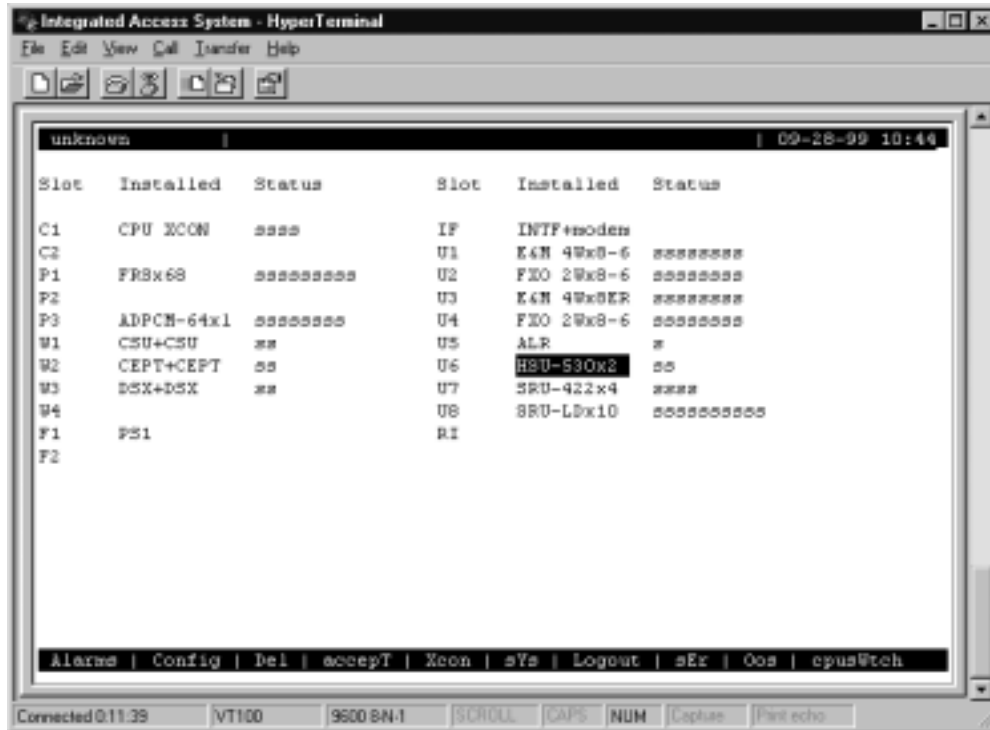

Figure 5-14. Typical Card Status Display

From the System Main Screen, you can also access other screens, as shown in Figure 5-14. These screens are described in the following paragraphs.

5.4.5 Server Card Status

Port status for the Server cards is determined in the same way as Voice and Data cards, with the possible status values of **s** (Standby), **a** (Active), and **r** (on a Redundant card).

Port status is determined somewhat differently for the MCC and IPR*4 Server cards, since these cards have more logical ports than can be represented on the screen.

5.4.5.1 MCC Card

The MCC card has a total of 132 logical ports:

- 1 Ethernet port (E)
- 3 high-speed ports (C1-C3)
- 128 user-scaleable ports

The status for these MCC ports is represented by ten characters. The first character represents the status of the Ethernet port. The second character represents the status of the combined C ports (C1-C3). The last eight characters represent the status of groups of 16 ports (1-16, 17-32, 33-48, 49-64, 65-80, 81-96, 97-112, and 113-128). If any one of the logical ports in one of these groups is active, the status of that entire group will appear as active (**a**).

5.4.5.2 WAN Card

There are several variations of the WAN card. On the main screen, the status will be shown for the type of card installed: CEPT for E1 cards, DSX for T1 cards, CSU for T1 mode with less repeaters. The status of the individual ports on the WAN card will display “**a**” for active, and “**s**” for standby.

5.4.6 Card Main Screens

Each card in the system has a Card Main Screen associated with it. You can go from the System Main Screen to any Card Main Screen and configure that card. From a Card Main Screen, you can access a Test Screen to perform tests on the card, or (in some cases) a Performance Monitor Screen to view transmission performance data.

Figure 5-15 shows a typical Card Main Screen. The highlighted line at the top of every screen is the header. It lists the node name of the system, the current card type and abbreviated description, the card design revision and serial number, and the current system date and time.

The card configuration parameters and current option settings appear in numerous rows and columns below the header. This region of each screen lists the options on the left and one or more associated columns of data fields from left to right. You can change the settings in those fields as required for each card.

The status and data entry change line appears just above the bottom line of the screen. When you choose a field to edit and press <Enter>, this line shows the currently available option settings for that field. Make all configuration changes on this line.

The highlighted area in the upper right corner shows the current alarm status data. In Figure 5-15, an Out-Of-Service (OOS) alarm has occurred on the card in chassis slot U3.

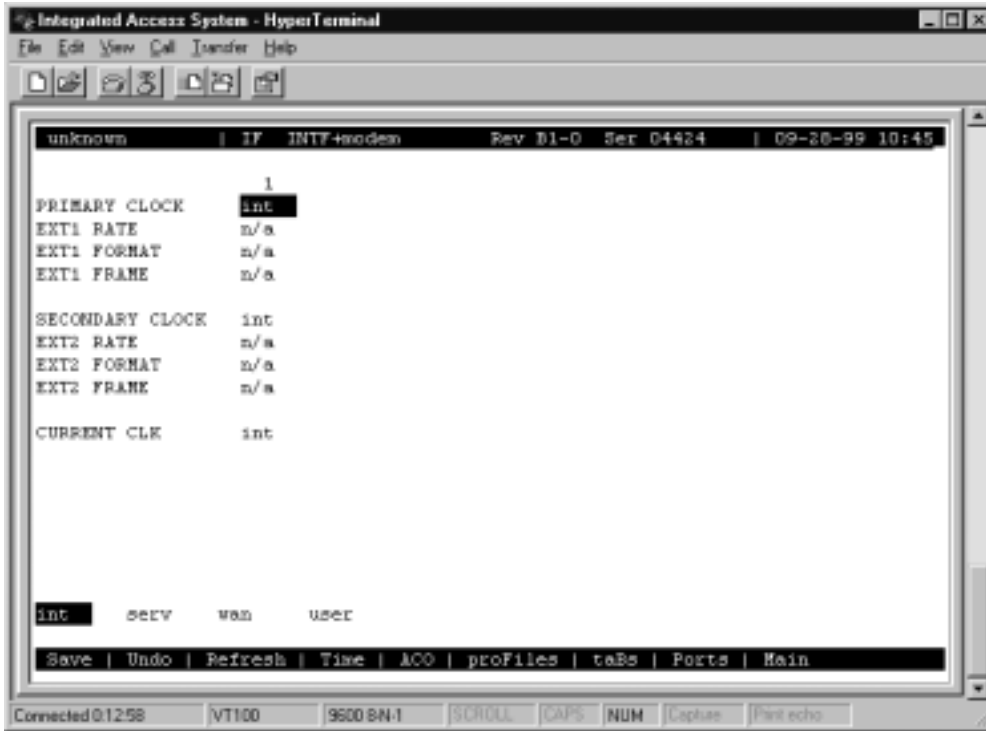

Figure 5-15. Typical Card Main Screen

The bottom line of each Card Main Screen lists other actions you can perform by simply pressing the letter key that corresponds to the uppercase letter of your desired action. In Figure 5-15, for example, if you press “s”, you will invoke the **Save** command, which saves the current option settings in the system’s memory. The actions you can choose from this line depend on which card and screen you are currently accessing. Refer to the associated chapters in this guide for descriptions of those actions.

5.4.7 Test and Debug Screen

You can also go from the System Main Screen to a Test and Debug Screen, which allows you to perform system-level maintenance operations. You can back up the system configuration onto an external computer after saving and subsequently editing it, and (if necessary) you can restore that configuration to the system. You also can erase the system configuration and restart the system with a single “zip” command. Or, you can re-register your system configuration if you change to a different chassis.

The system software also has a built-in debugging utility. However, this utility is only available to factory software engineers. The system maintenance functions are described in the “Testing and Debugging” section later in this chapter.

5.4.8 Time Slot Configuration and Cross-Connect Screens

From the System Main Screen, you also can access a Configuration Screen that lets you automatically configure the system. This time-saving function assigns DS0 time slots of the system’s T1 and E1 WAN lines to certain user voice and data cards in your system. Or, you can access a lower-level screen that lets you cross-connect DS0 time slots between two T1 or E1 lines connected to the system. Refer to these time slot configuration operations later in this manual.

5.5 Card Configuration

5.5.1 Selecting and Configuring Your Cards

The System Main Screen lists all installed cards next to their slot numbers. To access a card from the Main Screen. Move the cursor in the Installed column with the arrow keys until the desired card is highlighted, then press <Enter>. The associated Card Main Screen now appears.

Use the arrow keys to move the cursor around in any card screen. When changing card parameters, some settings require you to enter your own values on the keyboard, while others allow you to select from a list of pre-programmed option settings.

To enter a user-defined value in a field, first highlight that field by moving the cursor to it and press <Enter>. Then, type the desired value on your keyboard and press <Enter> to store it in that field.

To choose an option setting from a list of displayed options, press <Enter> with the associated parameter field highlighted. A series of available option settings now appear for that field. Use the right-arrow and left-arrow keys to move the cursor to the desired setting, and press <Enter> to store that setting in the highlighted field.

Be sure to configure each card according to your networking requirements. From the System Main Screen, select each card in turn and change the options for that card from its Main Screen. Select the **Save** command by pressing “s” after making all the changes for a card, then press “m” to return to the System Main Screen and choose another card. Similarly configure each remaining card in your system.

Once configured, the card settings are permanently stored in Non-Volatile Random Access Memory (NVRAM) on the Interface card. This card is labeled INF on its faceplate ejector. You can then replace faulty cards in your system without having to reconfigure the new cards.

If you replace a card with an identical type new card, the system automatically copies the NVRAM data from its Interface card to the new card. However, if you replace a card with a different type of card, you must first delete the existing card settings from the slot before the new card will be recognized by the system. The System Main Screen will display the new card type with a status of “**REJ**” (**Reject**).

If a card (voice or data) in a slot is going to be changed with a different type proceed with the following:

1. Physically remove the card from the slot.
2. From the Main Screen, highlight the card slot and press “D” (**Del**). This deletes all settings from the removed card slot.
3. Place the new card in the slot and ensure that it is properly seated.

5.5.2 Recording Your Configuration Settings

You should always record the configuration option settings for each card after you set them. This information may be needed later for system operation. To record the card configuration data, first photocopy the pages showing the Card Screens in the associated chapters of this guide. Then, mark the option settings you want to use on those pages, and store the pages in a safe place where they can be readily obtained.

You can also record screen settings by “capturing” each edited screen onto your computer terminal while you are logged into the system. To do this, your computer must have a software program capable of capturing the actual screens as text files. The communications software you use to access the system may have this ability. You can then copy the screens to a word processing program, print them out, and store them electronically.

Still another method for capture is by making an electronic copy of the database, specifically the ASCII option, as described in Section 5.12.8 on page 51 of this chapter.

5.6 Reinitializing the System

The system stores information about its currently installed cards, the card configuration option settings, WAN connections, passwords, and other data in nonvolatile memory (NVRAM) on the Interface card. This card is labeled INF-E, INF+M, or INF on its faceplate ejector. Your connection to the system is through the Interface card.

When you remove and replace most card types, the NVRAM remembers the previous card settings. If the same kind of new card is inserted in the slot, you do not need to reprogram the settings. However, if you replace a card with a different type of card, the system lets you delete the old card, so that you can program new parameter settings for the new card (see the **Accept** function described in this chapter).

When you remove and replace an Interface card, the system automatically resets itself. If the new Interface card was not previously used, you must re-register the system. If the new Interface card was previously used, either it will use its internal settings, or the system will request that you “zip” it, causing it to be reprogrammed.

When you remove and replace a CPU card with an **identical** CPU card, the system re-initiates the Interface card’s NVRAM and writes the old parameters (including your current passwords) to the new CPU card. Your CPU card is labeled CPU-6 on its faceplate ejector.



Note: *You must always use a CPU-6 XCON card in your system. CPU cards with any other designations marked on their ejectors will not work.*

If the CPU card is replaced with an identical CPU card but the new card has a different firmware version, a “zip” may need to be performed. The exception is when the firmware change is a maintenance release. (For example upgrading from a 5.3.0 to 5.3.1).

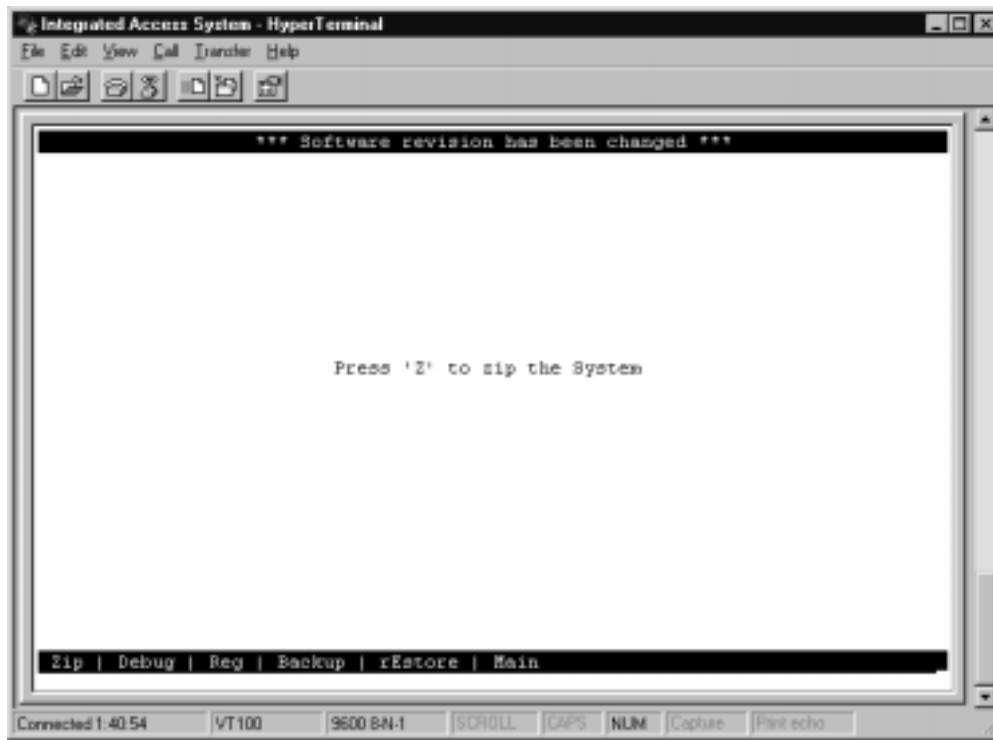

Figure 5-16. Cold-Start NVRAM Test Screen.



WARNING!

The "Z" command will start the ZIP process. "Zipping" the system deletes all of the information stored on NVRAM and resets it. All cards must then be completely reconfigured.

When you press “z”, the system will display the main log-in screen and ask for password authorization from either the Manager or Operator access level. After you enter the correct password, the system asks, "OK to Zip the system (y/n)"? Press “y” to have the system test and re initialize itself. All NVRAM information will be erased from the Interface card, and a new log-in screen will appear.

A new feature on the IMACS that provides for remote actions is the ability to retain the IP information when doing a ZIP command. The ZIP command deletes all provisioning on the IMACS. However, starting in CPU-7, the user will be prompted if they want to delete the IP

information. Choosing to not delete the information will set the unit to default, but still retain IP connectivity. This is useful when doing remote drastic recovery on the unit. However, caution should still be exercised. If the IMACS is accessible via the IP address over a WAN DS0 timeslot, the WAN information is still deleted and the node will not be accessible. Caution should always be exercised when performing the ZIP function and it is always prudent to have someone at the IMACS location when executing a ZIP.

5.7 Alarms

Alarms warn you of problems by reporting possible system hardware or external facility failures. The Alarm screen is accessed from the System Main Screen by pressing the "A" key to go to the Alarm Screen (see Figure 5-17 through Figure 5-19). The Alarm Screen displays the currently active alarms (if any) and provides access to the Alarm Filters and Alarm History screens. Figure 5-17 shows a typical Alarm Screen with an active alarm.

Starting in CPU load 7.2.1, alarm events are also sent to the Syslog server. See "SYSLOG" starting on page 7-26 for more information regarding the syslog server.

5.7.1 Alarm Screens

Refer to Figure 5-17. To view the current system alarms, you can go from the System Main Screen to an Alarm Screen. From the Alarm Screen, you can then go to an Alarm Filters Screen and set up the alarm reporting filters. Or, you can access an Alarm History Screen (log) and view alarms that were previously logged by the system. These screens and operations are discussed in the "Alarms and Alarm Filters" section later in this chapter.

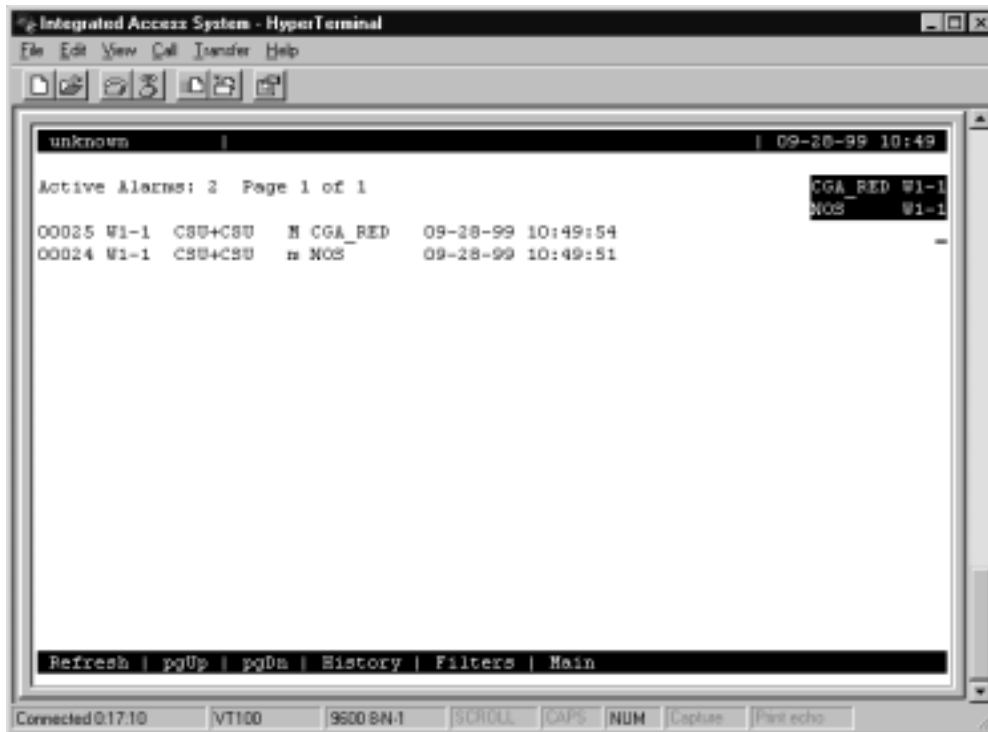

Figure 5-17. Typical Alarm Screen

The first character set (**00025** in the above display) is the Alarm Sequence Number. This is a sequential number from **1** to **65,535**. It identifies the alarm for tracking and maintenance. In the above example, the Alarm Sequence Number is **25**.

The second character set (**w1-1**) is the location of the problem by chassis slot number and port number. In this case, the WAN card in chassis slot W1 is affected, and port 1 of that card has reported the alarm.

The third character set (**CSU + CSU**) is the type of card affected (in this case, a WAN card with two T1 CSU modules).

The fourth character set is the alarm modifier (in this case, **M** indicates a major alarm). See the “Alarms and Alarm Filters” section later in this chapter for more information about alarm modifiers.

The fifth character set (**CGA_RED**) is the type of alarm generated (in this case, a CGA-Red alarm on WAN port W1-1).

The last two character sets are the date and time the alarm was logged.

5.7.2 Alarm Filter Settings

You can set filters for each alarm so that the alarm reports occurrences in a number of different ways. Figure 5-18 shows the Alarm Filters screen, which is accessed by pressing "f" (Filters command) on the Alarm Screen.

unknown		1	2	3	
OOS	Out of Service	log	major	acc-off	CGA_RED W1-1
NOS	No Signal	log	minor	acc-off	NOS W1-1
LOS	Loss of Sync	log	minor	acc-off	
YEL	Yellow Alarm	log	minor	acc-off	
AIS	Alarm Info Signal	log	minor	acc-off	
CGA_RED	Carrier Group - Red	log	major	acc-off	
CGA_YEL	Carrier Group - Yellow	log	major	acc-off	
EER	Excessive Error Rate	ignore	minor	acc-off	
SENSOR	Alarm card sensor	log	minor	acc-off	
DCHAN	D-chan out of service	ignore	minor	acc-off	
SWITCH	Switch to redundant card	report	major	acc-off	
UCA	User card/port alarm	ignore	minor	acc-off	
RESET	System reset	report	major	acc-off	
ACO	Alarm Cut-Off	log	minor	n/a	
SYNC	Clock Sync Alarm	ignore	minor	acc-off	
EER-3	Error rate above 10e-3	ignore	minor	acc-off	
PLC_OOF	DS3 PLCP Out of Framing	ignore	minor	acc-off	
PLC_LOF	DS3 PLCP Loss of Frame	ignore	minor	acc-off	
PLC_YEL	DS3 PLCL Yellow Alarm	ignore	minor	acc-off	

Save | Undo | Refresh | Main

Connected 0:17:45 VT100 9600 BN-1 SCROLL CAPS NUM Capture Print echo

Figure 5-18. Alarm Filters Screen

The first column of the Alarm Filters Screen is the alarm abbreviation that appears when an alarm is generated. The second column is the associated full name of each alarm. Table 5-7 describes each alarm appearing in the Alarm Filters Screen.

The third column contains the filters **ignore**, **log**, and **report**. Set the filter to **ignore** if you want the system to ignore the alarm. Or, set it to **log** if you want the system to show the alarm report on the screen and also log it into the Alarm History, as described later in this chapter.

Set the filter to **report** if you want the system to send (report) the alarm indication to a remote device. With this setting, the system will also display the alarm report on the screen and log it into the Alarm History.

The fourth column of the Alarm Filters Screen contains the filter modifiers **info**, **minor**, **major**, and **crit**. This column specifies a level of importance (information only, minor alarm, major alarm, or critical alarm) for each alarm. These settings are described later in this chapter.

The last column sets the alarm cutoff (ACO) to **aco-off** or **aco-on**. These settings are explained later in this chapter.

The filter in the third column takes precedence over its modifier. If, for instance, you have an alarm filter set to **ignore**, the setting of the modifier as **info**, **minor**, **major**, or **crit** will be ignored. Refer to system specifications section in this manual for alarms and their meanings.

Table 5-7. Alarm Filters

Filter	Alarm	Meaning
OOS	Out of Service	The card, power supply or ringing generator is faulty or has been removed from the unit.
NOS	No Signal	Incoming WAN signal is lost.
LOS	Loss of Synchronization	Frame Alignment is lost.
YEL	Yellow Alarm	The system has received a Yellow Alarm signal from a remote device. Usually received when the device loses WAN signal or synchronization.
AIS	Alarm Information Signal	The system has received a Blue Alarm signal from a remote device. Usually received when the remote or intermediate device has a major failure.
CGA_RED	Carrier Group Alarm - Red	The local incoming WAN signal has a serious problem and trunk conditioning is started. After receiving a RED alarm (NOS or LOS) for 2-3 seconds, the system initiates the appropriate trunk conditioning sequence (see voice cards for information about the TC_CGA setting) and sends a Yellow Alarm to the remote device. If the system is in drop/insert mode, it also sends an AIS signal to the downstream equipment.
CGA_YEL	Carrier Group Alarm - Yellow	The system has initiated trunk conditioning in response to a Yellow Alarm from a remote device. After 2-3 seconds, the system initiates the appropriate trunk conditioning sequence (see voice cards for information about the TC_CGA setting).
ERR	Excessive Error Rate	The error rate measured by the system has exceeded the threshold set on the WAN card.
SENSOR	Alarm Card Sensor	The Alarm Card sensor has received an alarm indication from an attached device.
DCHAN	D-chan out of service	If the network side D channel loses contact with the user side, an alarm message will be generated. The alarm message will show the slot # and D channel # where the problem exists.
SWITCH	Switch to redundant card	The primary card has failed and the system has switched to the redundant card.
UCA	User card/port alarm	One or more active ports on a PPHON (PPO or PPS) card are not working properly. Voice ports will show an alarm for excessive signaling transitions.
RESET	System reset	The system has been reset by either loss of power or by a system software upgrade.
ACO	Alarm Cut-Off	The ACO option forces you to manually clear certain alarms. Without this option, self-correcting alarms might not be noticed. When the ACO option is set to either Report or Log and the modifier is set to Major, alarms will report normally but will also generate an ACO alarm. If the modifier is set to Minor, it will not generate the ACO alarm. If the filter is set to Ignore, no alarms will be generated. This can depend on whether or not CPU is set for latch or CUR .
SYNC	Clock Sync Alarm	The SYNC alarm is generated when either the primary or secondary external clock source is lost. This alarm is in addition to the condition that lost the clock source (CGA-RED or OOS).
ERR-3	Excessive Error Rate (10e-3)	While using transcoder operations for E1 that involve downstream tributaries, setting EER-3 to "report" will cause an alarm to appear on the local system when E1 transmission errors exceed 10e-3 (1 in 1000). The local EER-3 alarm will identify the effected WAN link (i.e., W1-1) and take it out of service. Simultaneously, the downstream tributary will receive an AIS alarm to warn them of the condition.
PLC_OOF	DS3 PLCP Out of Framing	Physical Layer Convergence Protocol is Out of Framing.
PLC_LOF	DS3 PLCP Loss of Frame	Physical Layer Convergence Protocol has Lost Framing.
PLC_YEL	DS3 PLCL Yellow Alarm	Physical Layer Convergence Protocol is reporting a Yellow Alarm.
BP_OOS	Backplane Out of Service	Indicates an internal corruption of a message that may be caused by a variety of external or internal events. (See further description of BP_OOS below.)

5.7.3 Alarm Modifiers

Each alarm may also be designated as **I=info**, **m=minor**, **M=major** or **C=crit**. The filter modifier appears on both the active alarm and alarm history screens.

If the system has an External Alarm card (optional), the occurrence of any alarm designated as **crit** will trigger a form-C relay contact on the External Alarm card. The relay contact action sets off an annunciator or lamp at the equipment site. Similarly, the occurrence of any alarm designated as **major** triggers a different contact and activates another external indicator. Refer to the Alarm Card Reference Guide for more information on the External Alarm cards.

5.7.4 Alarm Cutoff (ACO)

The ACO (Alarm Cutoff) security feature is used by the system to alert an operator to alarms that clear themselves while the system is unattended. The ACO option settings are **aco-on** and **aco-off**. If ACO is set to report or log alarms, any alarm set to report or log with a major modifier brings up an additional alarm message on the screen. You must manually clear this message, which is the ACO alarm message (depends on whether or not CPU is set for latch or CUR). The ACO is used with the node port of the Interface card. It can also trigger an external alarm device, such as a bell or lamp, that must also be manually cleared.

All ACO alarms must be cleared from the Interface card screen. ACO alarms can be cleared automatically or manually.

5.7.5 Backplane Out of Service (BP_OOS)

The host CPU polls each card periodically for a variety of information and alarm status. The card responds with a multi-field message to the host with such information as alarm condition (either active or not and type of alarm), slot number, etc. Alarms are automatically set or cleared based on the contents of these messages returned by each card. For the BP-OOS alarm, the slot number reported from a card is corrupted for an OOS type alarm. The CPU reports BP-OOS when it indexes outside the boundaries of a defined alarm.

Possible causes for this alarm type include:

1. Improper grounding of the system. Floating lines on the backplane can cause the message between card and host to be corrupted, so proper grounding can have a positive effect on removing this condition.
2. Improper seating of cards may cause an intermittent error where the CPU receives incorrect data from the card.
3. Defective serial memory on a card or defective NVRAM on the Interface card can also cause this condition to occur in the field.

4. In earlier software releases, if an operator erroneously attempted an OOS operation on an empty slot, a BP-OOS alarm would be generated. Protection for this condition was added in recent software releases to prevent this alarm from being reported under this condition.

Once activated, this alarm can only be cleared as follows.

- a) For cause type 4 above, contact technical support to clear the alarm that does not require step b) to be performed.
- b) For all conditions other than type 4 above, the system must be zipped (resetting all the possible alarm codes off).

5.7.6 Alarm Handling

The **report** alarm function attempts to send alarm information to a remote printer, network management system (NMS), or other device, in addition to recording the alarm in the Alarm History log. These features use the built-in serial port and modem on the Interface card. You will need to change the settings in the Ports screen on the Interface card to be either modem or printer, and the printer (Prt) screen on the CPU card to activate the alarm reporting functions to a printer or modem interface.

Alarms set to either **log** or **report** record occurrences automatically to the Alarm History Screen. To view that screen, press “**h**” (**History** command) in the Alarm Screen. Figure 5-19 shows a typical Alarm History Screen, in which you can update the log with any new alarms that occur. To do this, press “**r**” to select **Refresh** in the Alarm History Screen. Or, to delete all entries in the log, press “**c**” to select **Clear** in the Alarm History Screen.

The alarm log may contain more than one screen (page) of data. To scroll through the log, press “**u**” or “**d**” (**pgUp** or **pgDn**) to move up one page or down one page at a time. The latest alarms appear at the beginning of the log, which is on the first page of the alarm log.

All alarms (except those set to **ignore**) appear in the Alarms field in the upper right corner of the screen, regardless of their setting in the Alarm Filters screen. The display in the Alarms field is an abbreviated version of the alarm name and slot number. For example, “OOS U3” indicates that the card in user slot U3 is out of service.

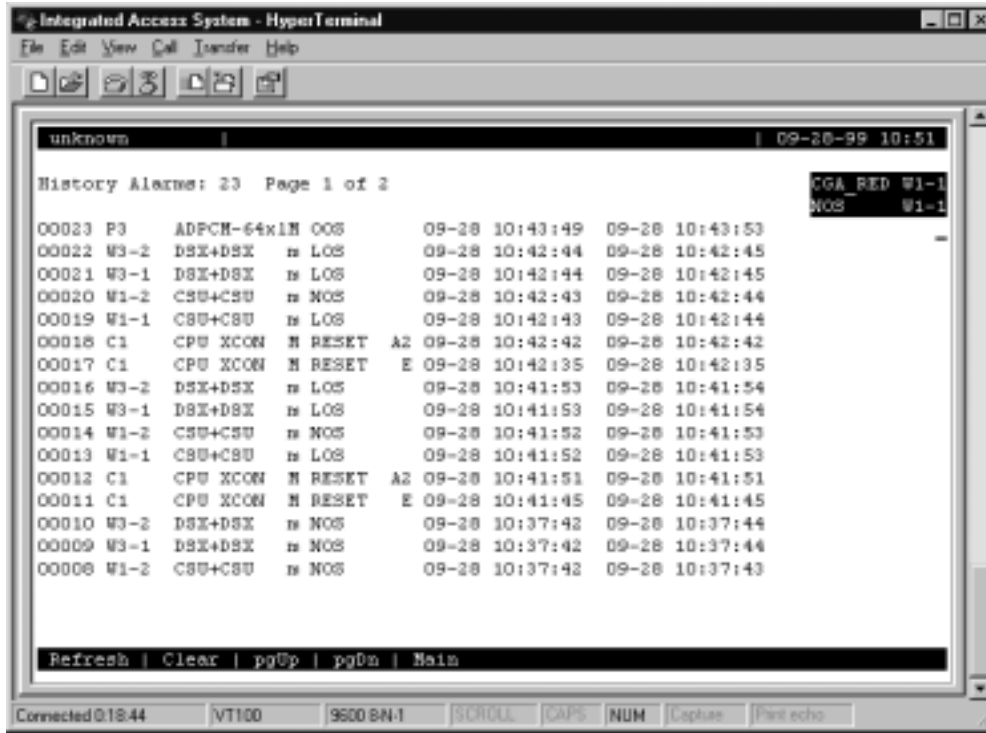

Figure 5-19. Typical Alarm History Screen

5.8 Time Slot Configuration Screen

From the System Main Screen, you can access a Configuration Screen by pressing “c” (**Config**) that lets you automatically configure the system. This time-saving function assigns DS0 time slots of the system’s T1 and E1 WAN lines to certain user voice and data cards in your system. Or, you can access a lower-level screen that lets you cross-connect DS0 time slots between two T1 or E1 lines connected to the system. Refer to these time slot configuration operations later in this manual.

5.9 Deleting an Out of Service Card

When a user card is out of service the screen will display an OOS in the status field next to the associated card installed. If you still want to remove this card press “d” (**Del**) to delete this card from the System Main Screen. The system will display a message, “OK to lose card settings (y/n)?”, press “y” and the system will remove that card from the System Main Screen.

5.10 Accepting New Card Settings

When a user card is replaced with a different type of card the system will remove the current card settings. The system will show “REJ” on the System Main Screen. Press “t” (**accept**) in the System Main Screen to accept the new settings.

5.11 Cross-Connecting (XCON)

From the System Main Screen, you can access a Cross-Connect Screen by pressing “x” (**Xcon**) that lets you cross-connect WAN time slots between T1 and E1 links. Refer to the Cross-Connecting WAN Time Slots Section 5.20 on page 73 of this chapter.

From the XCON screen, the user can access the AMT feature, which has been substantially changed over the initial offering.

```

Node 23      | C2 CPU XCON      Rev A0-0 Ser 00111 | 09-03-13 14:23
page: 1 of 1
CIRCUIT ID   W/U   TS/BW TEST W/U   TS/BW TEST  TYPE  TC   CNV
Add | uDate | dElete | pgUp | pgDn | View all | Tads | amt Options | Main

```

Figure 5-20.Xcon Screen - amt Options

Selecting 'O' from the XCON screen for the amt Options takes the user to the Alternative Mapping Table (AMT) feature, as described in the following section.

Included in the feature changes are associated syslog events. See "SYSLOG" starting on page 7-26 for new syslog events related to the ATMT feature.

5.11.1 Alternative Mapping Table

The Alternative Mapping Table (AMT) feature allows for a secondary configuration to be prepared and ready in case of a deemed system emergency which requires the IMACS traffic and services to be reconfigured. The concept behind this is that in a normally functioning environment the IMACS will carry a maximum of eight T1 or E1 facilities to the far-end. In an emergency, perhaps only two T1 or E1 facilities are 'guaranteed' by the service provider. The AMT feature allows for critical services and customers to be reconfigured to use these 'emergency' facilities. The AMT feature assumes that the far-end circuit will be mapped differently as well, as both ends must switch to an alternate map for the feature to be effective.

There are two methods to create an AMT MAP. The non-service affecting method uses the tool REMOTE AMT with a second remote node required to setup the alternative map. A database backup of the original node being configured is captured and edited on the remote shelf for use in an emergency by using the rETrieve option. The database backup is loaded and the cross-connections are manually changed in order to set up the AMT MAP using normal, IMACS provisioning functions. This edited database is then transferred back to the original node via tftp.

The second, service-affecting setup for the AMT MAP feature is by using ACTIVE AMT to create the AMT MAP. This method offers the benefit of making alterations to an existing customer configuration or to a pre-existing AMT MAP. To use this option, start by using the Copy option to create an AMT MAP that is an exact duplicate of the currently running configuration. The user would then manually switch to this new backup configuration, and then make any changes to the configuration to be used in an emergency or AMT active situation. Please note however, that **this is a service affecting procedure**, and changes made in this mode are both instantly implemented on the shelf, as well as written to the alternative map for use when the feature is set to active in the case of an emergency.

There are two alarms associated with AMT. The first is AMT ACT which indicates that the AMT MAP is active on the shelf. This alarm will remain active until a manual switch is performed to switch back to the normal operating configuration.

The second alarm is SYNCAMT. This alarm indicates that the installed cards on the system do not match the installed cards on the AMT MAP. When this occurs, **NO AUTOMATIC SWITCHING will be performed until the situation is remedied**. For the use of this feature, the stored configuration cannot and will not be used, and invalidates the ability to switch. This alarm can be resolved by creating a new AMT MAP by one of the two methods described above.

To access the AMT feature, the user needs to go to the sYstem level where the AMT feature exists, as seen in figure Figure 5-21 on page 5-39. You can see from this Figure that the user has to choose which provisioning method to use for AMT. The remote AMT (rem amT) is a non-service affecting method to provision the circuits, but requires the use of a second shelf. The other option is Act AMT (Act amt), which allows for on-shelf provisioning. This latter method is a **service affecting** method to provision the emergency circuit setup.

```
Node 23 | Alternate Mapping Table Options | 09-03-13 14:29
Active amt | Remote amt | amt Help | Main
```

Figure 5-21. Alternative Mapping Table Options Screen

We will address these two setup methods in the following two sections. The remote AMT procedure does not require any impact to the shelf in question, so we will cover that method first.

5.11.1.1 Remote AMT

AMT REMOTE is a non-service affecting way of provisioning an alternative cross-connection mapping table using an offline or remote IMACS shelf, consisting of only a CPU-7 processor and one of the supported Interface cards. Please note that the interface card used in the remote shelf should be of the same type as the in the working shelf. This configuration's sole purpose is to rEtrieve and load a working systems database, and allow the operator a means to edit the working configuration without the consequences of a in-service outage. The remote AMT main screen is seen below in Figure 5-22.

Node 23	AMT REMOTE NODE MGMT	09-03-13 14:31
	WAN PORT1	WAN PORT2
W1 ALARM SEL	Disable	Disable
W2 ALARM SEL	Disable	Disable
W3 ALARM SEL	Disable	Disable
W4 ALARM SEL	Disable	Disable
AMT TRIGGER	Any of the above	
AUTO SWITCH	off	
RESTART P1	no	
RESTART P2	no	
RESTART P3	no	
Save Undo Refresh rEtrieve Backup Help Main		

Figure 5-22. Remote AMT Main screen

This procedure requires the use of a tftp server and both systems must have IP service connectivity. The ideal location for the remote editing node is in a lab where IP connectivity can be locally controlled.

NODE SETUP PROCEDURE:

4. From the IMACS shelf where the AMT MAP feature is desired, login to the shelf and go to the sYs level, and then choose the Backup function. Choose the PROTOCOL of tftp, and then choose Go. The system will begin a backup of the running database. Note that a TFTP server must be operational in order for the database capture to be successful.

REMOTE NODE SETUP PROCEDURE:

1. On the remote shelf, ensure that only a single CPU-7 and appropriate IF card are installed.
2. Logon to the remote shelf, and go to the sYs level and select **Z** to zip the system. Confirm at both prompts to erase all pre-existing configuration data. The IMACS shelf will reboot as a result of this action.
3. Logon to the remote shelf using the default admin/admin username and password.
4. Navigate to the active CPU, carriage return, and then select tcp/Ip to enter IP information on the remote system.

5. From the CPU XCON IP screen, enter a valid IP address and subnet mask scheme for Ethernet TFTP access to the IMACS system. Save these changes and return to the main menu.
6. From the IMACS Main menu, once again select the sYs level, then choose the rem amT menu option.
7. At the AMT REMOTE NODE MGMT screen, choose rEtrieve. This command allows the node to pull in the working systems saved configuration as an alternative map. Choose the name of the file created under the NODE SETUP PROCEDURE above. The remote IMACS shelf will reboot to completely install the captured database.
8. Once restored, the remote shelf and working shelf will have the same IP address. It would be prudent to remove the IP connectivity at this time.
9. Login to the remote shelf, and note all the appropriate OOS alarms. A typical remote shelf is seen blow in Figure 5-23. This is normal, as the operating system database will report all the missing cards. Also note the AMT ACT alarm will be raised, to indicate the alternative map is presently active and being edited. These are all normal and expected system behaviors.

						11-06-12 17:30	
Slot	Installed	Status	Slot	Installed	Status	AMT ACT C1-1	
C1	CPU XCON	asss	IF	INTF-R+Ext			
C2	CPU XCON	OOS	U1	SRU-LDx10	OOS		
P1			U2				
P2			U3	HSU-530x4	OOS		
P3			U4	FXS 2Wx8-6	OOS		
W1	DSX+DSX	OOS	U5				
W2	DSX+DSX	OOS	U6				
W3	DSX+DSX	OOS	U7				
W4			U8	E&M 2Wx8-6	OOS		
F1	PS1		RI	RINGER			
F2							
Alarms Config Del accepT Xcon sYs Logout Oos cpusWtch							

Figure 5-23. Remote shelf with database restored

10. As the final step to the alternative map configuration, make any and all configuration changes that are desired to become part of the active configuration during an emergency. Please remember to save each and every change desired, as with normal IMACS configuration changes. **NOTE:** Creating the alternate map provides the user with the same editor as expected on IMACS. Care must be taken on provisioning the services, as normal idiosyncrasies exist. For example, setting up an LD-SRU service at 9600 sync and then changing the WAN will cause the circuit to revert back to 300 baud, async and stdby status. Careful provisioning and checking are required to ensure proper service provisioning on the alternate map.

11. Once all changes have been made to enable an emergency IMACS configuration, navigate back to the sYs / rem amT level and select Backup from this screen. NOTE: This backup must be used to backup an alternative map. Failure to use the backup command from the rem amT screen will fail to put the proper AMT flag surrounding the information, and the alternate map will not be correctly installed.
12. If removed, reconnect the IP connection and save the newly created alternative map to a TFTP server.

INSATLLING THE AMT MAP ON THE WORKING SHELF:

1. Now that an alternative map is created and exists, you must pull it into your working shelf. To accomplish this, go to the sYs / Act amt level.
2. From the AMT MGMT screen, choose rEstore to pull in the alternate map created in step 11 above. This will write the configuration to be used in the case of an emergency onto the IMACS in the protected storage area of memory for use upon operator command or one of the triggers set below initiates switching to the alternative map.
3. The user is now set to enable the trigger events, as seen in See “ALARM FILTER TRIGGERS.” starting on page 5-44

5.11.1.2 Active AMT

AMT ACTIVE is a service affecting method to provision an Alternative MAP, or AMT.

An AMT MAP is an alternate set of cross-connections that can be used when a facility fails in order to maintain service for critical customers. The alternate mapping table is inactive and secondary to the active base mapping table. Switching to the alternate map (AMT MAP) may be activated manually by the user at any time, or performed automatically upon user designated T1/E1 facility failure trigger settings in the ACT AMT menu screen. The Active AMT provisioning screen is seen below in Figure 5-24.

Node 23		AMT MGMT		09-03-13 14:33	
		WAN PORT1			WAN PORT2
W1 ALARM SEL		Disable			Disable
W2 ALARM SEL		Disable			Disable
W3 ALARM SEL		Disable			Disable
W4 ALARM SEL		Disable			Disable
AMT TRIGGER		Any of the above			
AUTO SWITCH		off			
RESTART P1		no			
RESTART P2		no			
RESTART P3		no			
Save Undo Refresh sWitch Backup rEstore Copy Help Main					

Figure 5-24.Active AMT main screen

An AMT MAP can also be created on a remote node and loaded via the rEstore function. See the AMT help for remote operation.

SWITCHING SETUP PROCEDURE:



Note: *This version of the AMT set up process is service effecting.*

1. From the AMT MGMT menu screen select **C**opy. This function copies the active cross-connect mapping table and stores it in the reserved alternative mapping table storage area.
2. From “AMT MGMT” menu screen select **s**Witch. This function switches from the active connections to the ALT MAP connections, and activates the AMT ACT alarm. At this point the active and AMT map cross-connections are identical, so a momentary service disruption may occur.
3. The alarm banner will now display the AMT ACT alarm. This confirms that the AMT feature is now active, and the system is running from the alternative map. Now the user can make changes to the configuration settings of the User, Server, WAN, CPU and IF slot menu screens. Please note that changes at this time are actively written to the shelf changing the running configuration, as well as to the Alternative Map to be activated in case of emergency.

4. Once all desired configuration settings have been completed for the alternate map, the user then needs to return to the AMT MGMT menu screen.
5. From the AMT MGMT menu screen select Backup. This function makes a backup copy of the ALT MAP using TFTP. This requires that a TFTP server is running and reachable on the customers IP network.
6. From the AMT MGMT menu screen select sWitch. This function switches from the active ALT MAP back to the BASE MAP and restores the original cross-connections. This will clear the AMT ACT alarm, and normal service will be restored.
7. The user is now set to enable the trigger events, as seen in See “ALARM FILTER TRIGGERS.” starting on page 5-44

5.11.1.3 ALARM FILTER TRIGGERS.

An example alarm filter setting screen is seen below in Figure 5-25.

Node 23	AMT REMOTE NODE MGMT		09-03-13 14:31
	WAN PORT1	WAN PORT2	
W1 ALARM SEL	Disable	Disable	
W2 ALARM SEL	Disable	Disable	
W3 ALARM SEL	Disable	Disable	
W4 ALARM SEL	Disable	Disable	
AMT TRIGGER	Any of the above		
AUTO SWITCH	off		
RESTART P1	no		
RESTART P2	no		
RESTART P3	no		
Save Undo Refresh rEtrieve Backup Help Main			

Figure 5-25. Alarm Trigger selections

The AUTO SWITCH field must be set to ON to enable an automatic switch from the BASE MAP to ALT MAP. The AUTO SWITCH field set to OFF disables automatic switching of the mapping tables. Automatic switching from BASE MAP to ALT MAP is generated by a facility CGA failure alarm filter trigger. Select and ENABLE any single or combination of WAN slot(s) and port(s) as active alarm filter trigger settings to generate an automatic switch to the AMT MAP.

If the user wants any single or combination of ENABLED WAN slots and/or port(s) to generate a switch to the ALT MAP, then set the AMT TRIGGER field to ANY OF THE ABOVE.

If all of the ENABLED WAN slot(s) and/or port(s) are desired to be in alarm before the automatic switch to the AMT MAP, then set the AMT TRIGGER field to ALL OF THE ABOVE. Note: Automatic switching is non-revertive and requires a manual sWitch to return the system back to the base map configuration and operation.

SERVER CARD SETTINGS:

The RESTART P1, P2, and P3 fields select how each server card will be treated upon a switch to the alternate map. If the field is left at the default of no, then the card will not be automatically restarted on a sWitch. If set to yes, then the card will be restarted upon a sWitch to or from the alternate map.

5.11.1.4 ALARM INFORMATION

There are two types of alarms associated with AMT. First is AMT ACT, which indicates that the AMT MAP is active. Switching back to the base map clears this alarm. Second is the SYNCAMT alarm which indicates that the installed card hardware does not match the card configuration saved on the alternative map. This alarm informs the user that the stored AMT MAP is now not valid for the currently running configuration, and a new AMT map must be created using one of the two AMT map creation methods. With alarm is occurring, NO AUTOMATIC SWITCHING can be performed until a new map is created, or the newly introduced hardware is deleted. This alarm essentially indicates that the AMT MAP feature is effectively disabled.

5.11.1.5 QUICK TIPS:

The Copy function makes a copy of the active configuration and stores it into the ALT MAP memory location.

The Backup function saves a copy of the ALT MAP via TFTP only when operating during normal BASE MAP operation.

An ALT MAP file created on a remote node may be loaded via TFTP using the rEstore function.

The sWitch is the manual switch from the BASE MAP to the ALT MAP or from the ALT MAP to the BASE MAP.

5.12 System Level Maintenance

You can also go from the System Main Screen to a Test and Debug Screen, by pressing “y” (sYs) which allows you to perform system-level maintenance operations. You can back up the system configuration onto an external computer after saving and subsequently editing it, and (if necessary) you can restore that configuration to the system (*refer to the backup and restore section later in this chapter*). You also can erase the system configuration and restart the system with a single “zip” command. Or, you can re-register your system configuration if you change to a different chassis.

The system software also has a built-in debugging utility. However, this utility is only available to factory software engineers. The system maintenance functions are described in the “Testing and Debugging” section later in this chapter.

5.12.1 Test, Debug, Backup & Restore

Advanced configuration and diagnostics are available through the use of the sYs (sYstem) command from the System Main Screen. Pressing “y” brings up the Test and Debug screen shown in Figure 5-26.

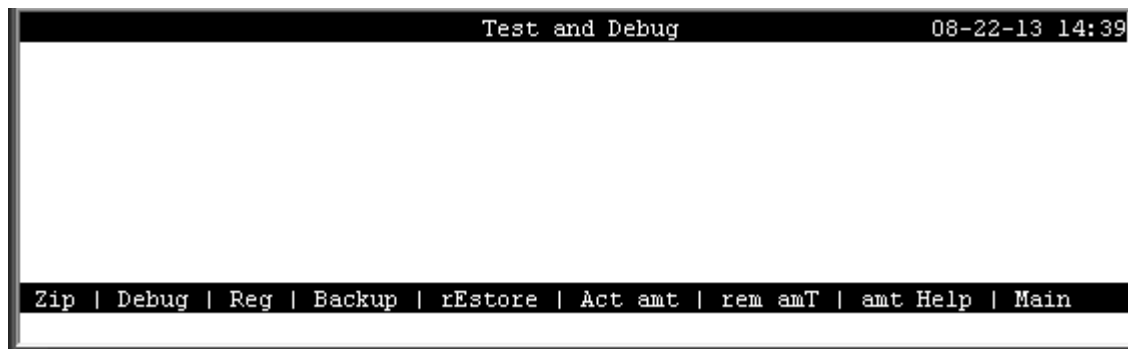

Figure 5-26. System Test and Debug Screen

5.12.2 Zipping the System

Figure 5-27 shows a typical Zip Screen, which appears when you press “z” in the Test and Debug Screen.



CAUTION!

The "Z" (Zip) command allows a user logged in under the Operator or higher password level to reprogram the entire system. Because the options for all cards in the system will revert back to their original factory settings, be sure to carefully consider the consequences of "zipping" your system before doing so.

```
Test and Debug                                08-22-13 14:39
Zip will reboot the system. Ok to Zip (y/n)?
Zip | Debug | Reg | Backup | rEstore | Act amt | rem amT | amt Help | Main
```

Figure 5-27.Zip Screen

5.12.3 Debugging the System

The **D** (Debug) command is only available to factory personnel with a password authorization higher than "Superuser." It gives access to the system software coding.

5.12.4 Registering the System

The **R** (Registration) command allows a user with Operator or higher password authority to change the system registration. The original registration is explained earlier in this chapter. You must have this information to properly re-register the system. **Do not use this command during normal system operation.**

The registration procedure consists of three steps. First, you must enter the vendor code. Then, you must select the type of chassis used. Finally, confirmation of the proposed changes is required (**Y** = yes, **N** = no).

5.12.5 Pre-TFTP Backup and Restore Preparation

To perform backup and restore uploads/downloads via the TFTP function, one of the following three methods of connection to a Local Area Network (LAN) network must first be selected.

1. The first and preferred option is through the Ethernet port on the CPU card.
2. The first option requires that the system to which you will download be powered and running through an active MCC server card that is connected to a LAN. The connection must be made either in the box that will receive the downloaded or in a remote box routed through the local CPU that is set as a gateway using IP protocol. You must be able to ping the MCC card and the local and remote CPU host IP addresses from the PC or server that you intend to use as a TFTP server and vice versa. The DEF RTE on the MCC Ethernet configuration screen must be set to *static* and must include the IP address of the PC or server from which you are downloading the firmware. You may need to change the routing table on your PC to include the MCC ethernet address as the gateway, or the local host address as the gateway for the system receiving the file as the destination IP address.
3. The second option is to connect to the Integrated Access System interface card's COM (C1) port to which you will download the firmware using PPP or SLIP protocol at 19.2k or 9.6k respectively. Again, you may need to change the routing table on your PC and/or on the router or terminal server through which the PPP/SLIP connection runs.



Note: *Your PC must have some sort of TFTP software installed and running when you are downloading the binary files to the system. Consult the user guide accompanying the software for details on configuring and using the software.*

5.12.6 TFTP Backup for 7.x.y

Follow the instructions listed below to perform a TFTP backup.

1. Log into the Integrated Access System using the Manager Password.
2. Press “**Y**” for **System** at the main menu.
3. At the Test and Debug screen press “**B**” for **Backup**.
4. The NV Ram Backup screen will appear. Using the arrow keys to navigate the cursor, highlight the *Protocol* selection and press **Enter**.
5. Select **tftp** using the arrow keys and press **Enter**.



Note: *New in CPU 7.x.y is that we will automatically write the active database to flash first.*

6. Press “**G**” for **Go** - an NV image overwrite command confirmation appears (i.e., *Previous NV image, cksum: 0x2DF05, date 09-8-96 05:58 overwrite (y/n)?*). Enter “**Y**” for yes.
7. A series of four questions must be answered to complete the backup process. The questions are as follows:

The system asks for the desired number of mismatch retries. Enter an appropriate number between 1-40, with 20 as default. Press **Enter**.

The system asks for the desired number of Timeout Retries. Enter an appropriate number between 1-10, with 4 as default. Press **Enter**.

Next, the system requires the IP address of the PC or TFTP server to which the backup will be sent. Following entry of the IP address press the **Return** key to continue.

Finally, the system requires entry of the filename for the backup being performed. Following entry of a filename the backup process begins. A *TFTP backup complete* message appears when the process finishes.

5.12.7 TFTP Restore for 7.x.y

Follow the instructions listed below to perform a TFTP restore.

1. At the main menu press **“Y”** for **System**.
2. Press **“E”** for **Restore** at the Test and Debug menu.
3. Use the arrow keys to highlight the Protocol selection and press **Enter**.
4. Select **TFTP** and press **Enter**.
5. You will receive an NV Ram image overwrite confirmation message. Press **“Y”** for **yes**.
6. Enter the desired number of Mismatch retries and press **Enter**.
7. Enter the desired number of Timeout Retries and press **Enter**.
8. Enter the IP address of the PC or TFTP server and press **Enter**.
9. Enter the filename for the backup you wish to restore and press **Enter**. Restoration begins.
10. Following completion of the restoration process, the system will prompt to restore data with the image that was uploaded. Press **“Y”** for **yes**.
11. The system asks to reboot. Press **“Y”** for **yes**. The system reboots and configuration becomes active.

5.12.8 ASCII Backup Procedure

Follow the steps listed below to perform an ASCII backup.

1. Log into the Integrated Access System.
2. Press “**Y**” for **System** at the main menu.
3. At the Test and Debug screen press “**B**” for **Backup**.
4. The NV Ram Backup screen appears. Using the arrow keys to navigate the cursor, highlight the *Protocol* selection and press **Enter**.
5. Using the arrow keys highlight ‘**ascii**’ (ASCII is the normal default selection) and press **Enter**.
6. Prior to starting the backup and restore process you must set the terminal emulation package to XMODEM1K or XMODEM, otherwise the process will fail.
7. From the Terminal Emulation window select **Capture Text File**. The system will prompt for the desired filename and path to store the backup file. Following entry of this information press **Enter**. The filename must include **.txt** as an extension or the backup will not function properly.
8. From the NV Ram Backup screen press “**G**” for **Go**. The Integrated Access System begins transferring the configuration to a text file. Upon completion, the system prompts you to enter “**m**”. You must first select **Capture Text** from the Terminal Emulation Menu and select **Stop**. You may then proceed with pressing “**m**”.

5.12.9 ASCII Restore Procedure

Follow the steps listed below to perform an ASCII restore.

1. From the main menu press “**Y**” for **System**.
2. Press “**E**” for **Restore**.
3. Select “**ascii**” from the *Protocol* selection using the arrow keys to navigate. Press **Enter**.
4. Press “**G**” for **Go**.
5. From the Terminal Emulation Screen Menu select **Send Text File**. The system prompts for the filename and path. Following entry of appropriate information, the restore process begins. If a *process completed* message appears immediately following the start of the process, an error has occurred. If this happens, check to ensure that the file being sent to the system includes a **.TXT** extension.
6. Upon completion of restoration, the system prompts you to **press ESC twice**. The system then reboots itself.
7. Following reboot, press “**Y**” for **Yes** when prompted. The system configuration information should be restored.

5.12.10 XMODEM 128k and XMODEM 1k Backup

Follow the steps listed below to perform an XMODEM 128k or XMODEM 1k backup. (Note that XMODEM 128k is slower than XMODEM 1k.)

1. Log into the Integrated Access System on which the backup is to be performed.
2. Press “**Y**” for **System** at the main menu.
3. When the Test and Debug screen appears, press “**B**” for **Backup**.
4. The NV Ram Backup screen next appears. Using the arrow keys to navigate the cursor, highlight the *Protocol* selection and press **Enter**.
5. Select **xmodem** using the arrow keys and press **Enter**.



Note: *New in CPU 7.x.y is that we will automatically write the active database to flash first.*

6. Press **“G”** for **Go**. An NV Ram image overwrite command confirmation appears (i.e., *Previous NV image, cksum: ox2DF05, date 09-08-96 05:58 overwrite (y/n)?*) Enter **“Y”** for **yes**.
7. Prior to starting the backup or restore process, ensure that the PC emulation package is set to the XMOD128 or XMOD 1K type format, otherwise an error will occur during the process. XMODEM backup is now ready to proceed.
8. Select **xmod 128** or **xmod 1k** by highlighting *Protocol* using the arrow keys. Press **Enter** when the XMODEM protocol to be used is highlighted.
9. To begin backup, press **“G”** for **Go** and press **Enter**.
10. From the terminal screen select **“Receive File”** from the appropriate file menu. The system prompts for a backup storage directory and filename. Following entry of the appropriate information, backup begins. With most terminal emulation software (i.e., Hyperterminal, ProCom, or Smartcom) a status window will appear during the backup process.
11. A system backup completion message appears and the system then prompts you to press **Enter** to continue. The backup is now complete.

5.12.11 XMODEM 128k and XMODEM 1k Restore

Follow the steps listed below to perform an XMODEM 128k or XMODEM 1k restore. (Note that XMODEM 128k is slower than XMODEM 1k.)

1. Log into the Integrated Access System to be restored.
2. To restore a previous backup access the main menu. Press **“Y”** for **System**.
3. Press **“E”** for **Restore** at the Test and Debug screen.
4. At the NV Ram Restore menu select *Protocol* and press **Enter**.
5. Select the proper XMODEM transfer method and press **Enter**.
6. Press **“G”** for **Go** to begin restore. The system will prompt whether or not to overwrite the current NV Ram image. Select **“Y”** for **Yes** and press **Enter**.
7. From the terminal emulation window select **“Send File”**. Enter the correct location and filename of the backup to be restored and press **Enter**. Restoration should begin and a progress monitor screen will appear.
8. Upon completion of the restoration, the system prompts whether or not to restore the NV Ram image, select **“Y”** for **Yes**.
9. The system prompts whether or not to reboot. Select **“Y”** for **Yes**.

10. Following system reboot, login as usual and proceed as appropriate.

5.13 Taking a Card Out of Service

The user can “OOS” (**Out Of Service**) a card for various reasons by pressing “O” (**OOS**) from the System Main Screen. Some reasons that the card is in OOS state may be that the card isn’t working properly, the system needs a warm boot or troubleshooting a card. A card that is working properly cannot be set to Out of Service (OOS) without first removing the card.

5.14 CPU Switching

The 7.x host release provides CPU redundancy switching by pressing “W” (**cpusWtch**) from the System Main Screen. The CPU redundancy switching is from a CPU in slot C1 to a redundant CPU in slot C2. When this process takes place the CPU in slot C2 is now active and the CPU in slot C1 is redundant. Refer to the CPU Card Redundancy section later in this manual.

5.15 Time Slot Assignment

This section provides instructions for assigning DS0 time slots to the voice and data cards of the Integrated Access System. It also provides time slot cross-connection and broadcast setup instructions.

The Integrated Access System maximizes the use of incoming and outgoing T1 and/or E1 lines. You can do this by assigning specific channels, or *DS0 time slots*, to voice and data cards in the system. You also can cross-connect time slots between T1 and/or E1 WAN ports of the system.

The CPU Card allows you to connect one DS0 time slot to another. Throughout this chapter, these connections are called “pass-through” circuits because they link a time slot from one T1 or E1 line to another through the system. You can therefore have up to eight separate T1 or E1 links on four WAN cards, in any cross-connect combination.

The following sections of this chapter describe several ways for you to administer your networks and correctly allocate transmission bandwidth to meet your needs. The next section deals with assigning time slots to the user voice and data card. The second section describes a time-saving tool known as the *Configuration* option, which automatically assigns sequential WAN time slots to the ports of user voice cards.

The third section deals with cross-connecting WAN time slots to other WAN time slots. The fourth section addresses a special application that supports the ability to broadcast a data signal over multiple WAN aggregates.

The fifth section describes signaling status, signaling, and companding conversion. The last section shows you how to view the time slot map after making your assignments and cross-connections.

This chapter defines "assigning time slots" as the process of connecting user card ports to WAN ports and time slots, and it defines "cross-connecting time slots" as the process of connecting WAN time slots to other WAN time slots in the system.

5.15.1 Modes of Operation

In the 7.x system, the only mode available is *XCON*.

5.15.1.1 XCON Mode (XCON)

The XCON mode allows the user to cross-connect DS0s to user voice or data cards or to cross-connect any DS0 on any WAN card to any DS0 on any other WAN card in the system. The "Mode" setting on a WAN in a XCON system will only indicate the XCON option.

5.16 Assigning Time Slots

You must use a *time slot map* to specify the connections between all incoming and outgoing lines connected to the system. The time slot map lets you split up your T1 and E1 bandwidths into portions required for normal voice and data communications. It contains the connections for all cards in your system.

5.16.1 Assigning a Time Slot to a User Card Port

You can define a time slot map from any user card (data or voice) for connections involving that card, or from a WAN card for cross-connections involving only WAN cards. For example, Figure 5-28 shows the E&M Card Main Screen for the time slot assignments. Assign time slots to a voice card as follows:

1. From the System Main Screen, select the desired voice card and press <Enter>. That card's Main Screen appears.
2. Select the WAN port from which you want to assign time slots to the E&M card. In Figure 5-28, this is **W1-1** (for WAN 1, port 1).
3. Select a time slot (TS) for the first card port. A number appears at the bottom of the screen for the corresponding time slot on the WAN port.
4. Set the time slot number by using the up and down arrow keys to highlight it, then press the <Enter> key.

5. Change the STATE of the port from **stdby** to **actv**.
6. Repeat steps 2 through 5 for the remaining card ports, to assign time slots to them.
7. Press “s” to save your settings, using the **Save** command in the Card Main Screen.

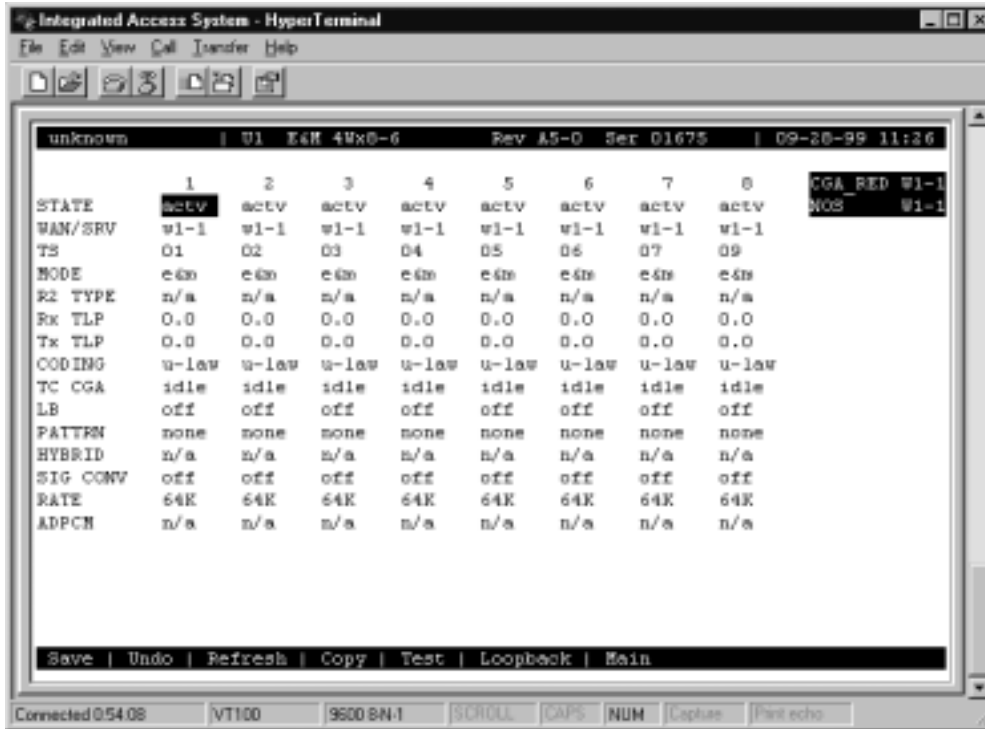

Figure 5-28. Typical E&M Card Time Slot Assignments

5.16.2 Assigning Multiple Time Slots to a Port

Figure 5-29 shows the HSU Card Main Screen for the time slot assignment example. Assign time slots to this card as follows:

1. From the Main Screen, select the desired HSU card and press <Enter>.
2. Select the WAN port to which you want to assign the HSU port. In Figure 5-29, this port is **W1-1** (for WAN 1, port 1).
3. Select the TS table. All time slots of the selected WAN port appear at the bottom of the screen. These are 1 to 24 for a T1 port, or 1 to 31 for an E1 port.
4. Place an “x” under each desired time slot, using the space bar to either select or de-select a time slot. Use the right arrow key to move to the next time slot (TS) for selection. Then, press <Enter>. In Figure 5-29 (for T1), the HSU port is assigned eight time slots (9 to 16). In Figure 5-30 (for E1), the HSU port is assigned eight time slots (17 to 24).
5. Change the STATE of the port from **stdby** to **actv**.
6. Press “s” to save your settings.



Note: In E1, time slots 0 and 16 are reserved.

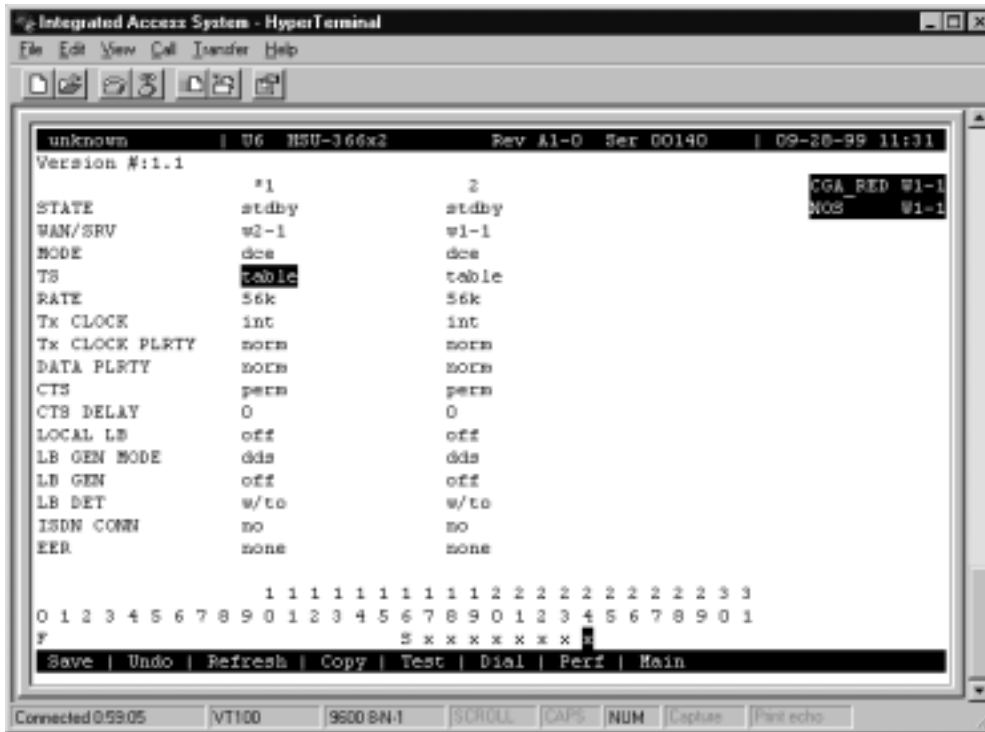

Figure 5-29. Typical HSU Card Time Slot Assignments for T1

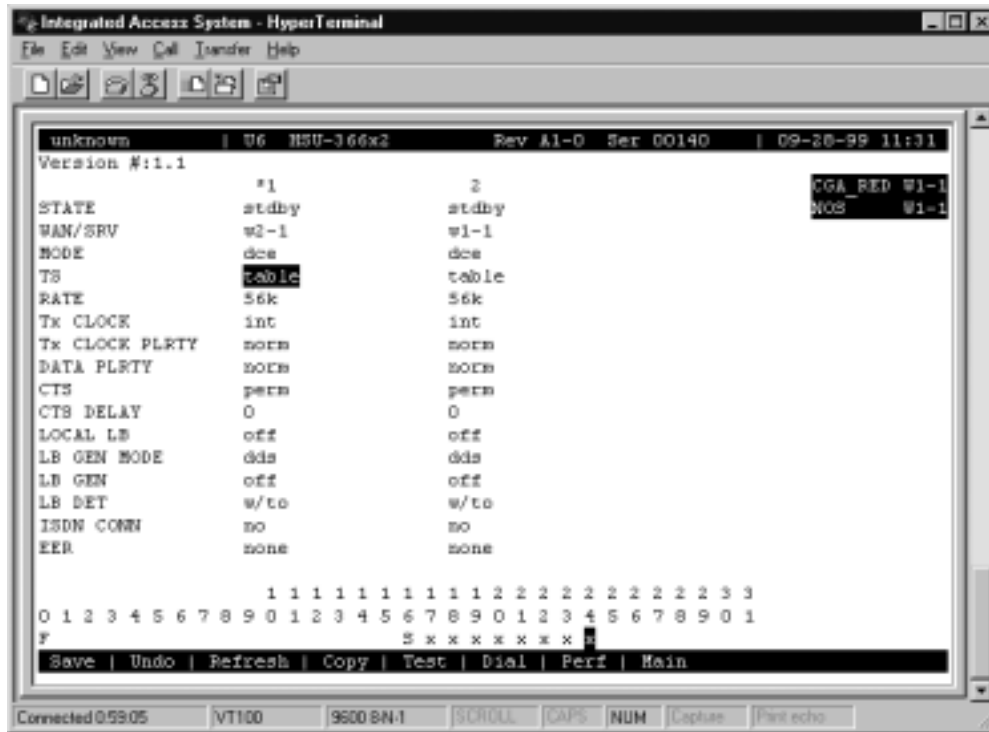

Figure 5-30. Typical HSU Card Time Slot Assignments for E1

5.16.3 Cross-Connect Model

The Cross-connect model allows you to access two T1/E1 links for each of four WAN cards, for a total of eight T1/E1 links. All WAN card connections to other WAN cards are accomplished through the cross-connect option on the System Main Screen, and must be individually specified. User cards on systems equipped with a CPU XCON card are assigned to WAN time slots.

5.17 Circuit Names

A cross-connect circuit in the IMACS is formed when assigning one resource to another using one or more time timeslots. Resources are User, Server and WAN ports.

When a resource is formed when assigning a user or server port to a WAN, a circuit is formed and given a name according to the type of circuit and type of resources assigned Table 5-8 lists the default circuit name assignments.

Table 5-8. Circuit Names

user_circuit	user card (FXS, SRU etc. to WAN, and FXS/FXO to ADPCM)
dsm_circuit	user card (DSM) to WAN
nx64_circuit	Nx64 port of CPU card to WAN
atmu_circuit	user card (FXS etc.) to ATM.
dhcan_circuit	ISDN/PRI server D-channel
dbri_circuit	BRI user card, D-channel to WAN
dbriiw_circuit	BRI user card, D-channel to ISDN/PRI circuit
ubri_circuit	BRI user card, B-channel to ISDN/PRI circuit or WAN
adpcm_user	user card (SRU to ADPCM)
mcc_network	MCC server card port to WAN
frs_network	FRS server card port to WAN
atm_network	ATM server card port to WAN
adpcm_network	ADPCM server card port WAN to WAN
fru_circuit	User (HSU) to FRS server pipe.
p_server	IPR server to FRS server internal pipe
user_circuit	default user card designator



Note: Not all circuits formed in the IMACS system have a direct relationship with a slot and unit. These types of circuits are not maintained by the CNA. Circuits made manually from the Cross Connect screen are not be affected by other resources. Examples of this type of circuit are WAN-to-WAN, broadcast, and Tads circuits.

5.17.1 Display and Change Circuit Names

Circuits can be displayed on the Cross Connect screen by pressing the "x" key from the main screen as shown below.

```

Node 23      | C2 CPU XCON      Rev A0-0 Ser 00111 | 09-03-13 13:51
-----|-----|-----|-----|-----|-----|-----|-----|-----
page: 1 of 1
CIRCUIT ID   W/U   TS/BW TEST  W/U   TS/BW TEST  TYPE  TC   CNV
adpcm2 23    w2-2   01*64 off   w1-1   01*64 off   d     moos n/a
E-n-M        w2-1   02*64 off   w2-2   02*64 off   d     moos n/a
HSU_OverSubscr w4-1   12*64 off   w4-2   12*64 off   d     moos n/a
HSU_4DS0     w4-1   04*64 off   w4-2   04*64 off   d     moos n/a
bridg_circuit p2-001 01*64 off   w2-1   01*64 off   v     n/a  no
Add | uPdate | dElete | pgUp | pgDn | View all | Tads | amt Options | Main

```

Figure 5-31. Cross Connect Screen

Circuits are then selected by moving the arrow keys up and down. Only network type circuits are shown on the first Cross Connect screen.

To display a list of all cross connects in the IMACS system from the Cross Connect screen, select "View All". Below is a sample of this screen.

```

Node 13 | C2 CPU XCON Rev A2-0 Ser 00192 | 09-03-13 13:28
page: 1 of 2
CIRCUIT ID   W/U   TS/BW TEST   W/U   TS/BW TEST   TYPE   TC   CNV
user_circuit u6-01 23*64 off    w1-2  23*64 off    d      n/a  n/a
user_circuit u7-01 12*64 off    w3-1  12*64 off    d      n/a  n/a
user_circuit u7-02 12*64 off    w3-2  12*64 off    d      n/a  n/a
user_circuit u7-03 12*64 off    w3-1  12*64 off    d      n/a  n/a
user_circuit u7-04 12*64 off    w3-2  12*64 off    d      n/a  n/a
user_circuit u3-01 12*64 off    w2-1  12*64 off    d      n/a  n/a
user_circuit u3-02 12*64 off    w2-2  12*64 off    d      n/a  n/a
user_circuit u1-10 01*64 off    w1-2  01*64 off    d      n/a  n/a
user_circuit u2-01 01*64 off    w2-1  01*64 off    v&s   user  no
user_circuit u2-02 01*64 off    w2-2  01*64 off    v&s   user  no
adpcm_user   u2-07 01*64 n/a     w4-2  01*64 n/a     v&s   user  no
adpcm_user   u2-08 01*64 n/a     w4-2  01*64 n/a     v&s   user  no

```

Bcast | uPdate | dElete | pgUp | pgDn | reName | Main

Figure 5-32. Cross Connect Screen -View All

Renaming Circuits

For the renaming feature, it does not matter which side of the circuit is selected, only the line at which the original circuit is printed matters.

After hitting the 'n' key on the ViewAll screen, circuits can be renamed by hitting 'Enter' as shown in the following figure.

```

Node 13 | C2 CPU XCON Rev A2-0 Ser 00192 | 09-03-13 13:35
page: 1 of 1
CIRCUIT ID   W/U   TS/BW TEST   W/U   TS/BW TEST   TYPE   TC   CNV
adpcm2_23    w2-2  01*64 off    w1-1  01*64 off    d      moos n/a
E-n-M        w2-1  02*64 off    w2-2  02*64 off    d      moos n/a
HSU_overSubscr w4-1  12*64 off    w4-2  12*64 off    d      moos n/a
HSU_4DS0     w4-1  04*64 off    w4-2  04*64 off    d      moos n/a
bridg_circuit p2-001 01*64 off    w2-1  01*64 off    v      n/a  no

```

HSU overSubscr w4-1 12*64 off w4-2 12*64 off d moos n/a

HSU OverAll

Save

Figure 5-33. Cross Connect Circuit (Rename)

Hitting "S" to save the circuit name changes the name of the circuit as shown in the below figure:

```

Node 13 | C2 CPU XCON Rev A2-0 Ser 00192 | 09-03-13 13:56
page: 1 of 1
CIRCUIT ID W/U TS/BW TEST W/U TS/BW TEST TYPE TC CNV
adpcm2_23 w2-2 01*64 off w1-1 01*64 off d moos n/a
E-n-M w2-1 02*64 off w2-2 02*64 off d moos n/a
HSU OverAll w4-1 12*64 off w4-2 12*64 off d moos n/a
HSU_4DS0 w4-1 04*64 off w4-2 04*64 off d moos n/a
bridg_circuit p2-001 01*64 off w2-1 01*64 off v n/a no
Add | uDate | dElete | pgUp | pgDn | View all | Tads | amt Options | Main
    
```

Figure 5-34. Cross Connect Rename Circuit (Saving)

Wan Circuits

Similar to other circuits, WAN circuits can be renamed from the WAN Cross Connect screen. The WAN Cross Connect screen lists circuits relative to the selected WAN. The figure below shows the three circuits available on WAN W1.

```

unknown | W1 DSX+DSX Rev E3-0 Ser 12345 | 08-11-2004 12:08
TS XCON TS CIRCUIT_ID TS XCON TS CIRCUIT_ID
1 p3-c3 D-00 frs_network 13
2 u5-4 D-01 user_circuit 14
3 uf-01 D-02 user_circuit 15
4 16
5 17
6 18
7 19
8 20
9 21
10 22
11 23
12 24
Refresh | Test | Main | reName
    
```

Figure 5-35. WAN Cross Connect Screen

Selecting the second circuit and hitting "enter" to rename, renames the circuit as shown below.

```

unknown | W1 DSX+DSX Rev E3-0 Ser 12345 | 08-11-2004 12:08
TS XCON TS CIRCUIT_ID TS XCON TS CIRCUIT_ID
1 p3-c3 D-00 frs_networkt 13
2 u5-4 D-01 user_circuit 14
3 uf-01 D-02 user_circuit 15
4 16
5 17
6 18
7 19
8 20
9 21
10 22
11 23
12 24

user_circuit p3-c3 01*64 off w1-1 01*64 off d n/a n/a

MyHSUCircuit_01

Save

```

Figure 5-36.WAN Cross Connect Screen (Rename)

After the renaming operation, the renamed circuit appears in the WAN Cross Connect screen as shown below:

```

unknown | W1 DSX+DSX Rev E3-0 Ser 12345 | 08-11-2004 12:08
TS XCON TS CIRCUIT_ID TS XCON TS CIRCUIT_ID
1 p3-c3 D-00 frs_networkt 13
2 u5-4 D-01 HSUCircuit_01 14
3 uf-01 D-02 user_circuit 15
4 16
5 17
6 18
7 19
8 20
9 21
10 22
11 23
12 24

Refresh | Test | Main | reName

```

Figure 5-37.Cross Connect Screen (Rename Displayed)

5.17.2 Backup and Restore Circuit Name Table

The circuit name table can be backed up and restored via NBR, adding additional flexibility for managing circuit names.



Note: *If a different version host CPU is used after circuit names have been renamed, the changed circuit names are maintained until a resource is changed, at which time the circuit name is restored to default. The names table will only hold names changed from the circuit's original name. If no circuits are changed, the circuit name table will remain empty and the names originally assigned to the circuit upon activation will be used.*

When TFTP is used or NVRAM is backed up to FLASH, entire NVRAM is saved, including the circuit name table. When ascii is selected, the circuit name table as Xcon Names has been added to the selection list as shown in the figure below.



Note: *A customer desiring to backup the contents of the IMACS onto an off-site node should always backup the current configuration to flash first! This will update the information that will be sent during the backup procedure.*

unknown		NVRAM Backup	08-23-2002 02:08
C1	backup	Instlal Table	backup
C2	backup	Cross Connect	backup
P1	backup	Alarm Filters	backup
P2	backup	Alarm History	backup
P3	backup	Xcon Names	backup
P4	backup		
W1	backup	PROTOCOL	ascii
W2	backup		
W3	backup		
W4	backup		
IF	backup		
U1	backup		
U2	backup		
U3	backup		
U4	backup		
U5	backup		
U6	backup		
U7	backup		
U8	backup		

Go | Copy | Main

Figure 5-38.NVRAM Backup Screen

When NVRAM is restored via TFTP or from FLASH, the entire image is transferred including the circuit name table. The circuit name table shown as Xcon Names has been added to the selections to allow ascii restore as shown in the figure below.

unknown		NVRAM Restore	08-23-2002 02:08
C1	restore	Instlal Table	restore
C2	restore	Cross Connect	restore
P1	restore	Alarm Filters	restore
P2	restore		
P3	restore	Xcon Names	restore
P4	restore		
W1	restore	PROTOCOL	ascii
W2	restore		
W3	restore		
W4	restore		
IF	restore		
U1	restore		
U2	restore		
U3	restore		
U4	restore		
U5	restore		
U6	restore		
U7	restore		
U8	restore		

Go | Copv | Main

Figure 5-39.NVRAM Restore Screen

Upon restoring the Xcon Names table, changed circuit names will be restored into NVRAM for recognition whenever the resource using it is next changed.

To change a circuit name permanently using NBR, change the circuit name in both the Xcon Names and the Xcon Names selections. Changing the names in the Xcon table alone will only preserve the name until next time the resource holding it is changed.

5.17.3 SNMP

Circuit names can also be configured using SNMP. The circuit name field in the Xcon ViewAll table supports SNMP Set commands.

5.18 DS0 Naming

This feature is designed to allow the user to assign a name to DS0 connections. Starting in CPU 7.1.2, we now allow for the user to assign a name to a DS0 termination on the IMACS. We support this naming for FXS, E&M, SRU, OHSU, Bridge and HSU terminations. The method that we use for this is similar to all the supported cards, so for simplicity we will use the E&M card as a sample. Figure 5-40 below shows the E&M standard provisioning screen.

Node 121		U3 E&M 4Wx8ER Rev XC-0 Ser 00022						10-30-12 17:52	
	1	2	3	4	5	6	7	8	
STATE	stdby	stdby	stdby	stdby	stdby	stdby	stdby	stdby	
WAN/SRV	none	none	none	none	none	none	none	none	
TS	n/a	n/a	n/a	n/a	n/a	n/a	n/a	n/a	
MODE	e&m	e&m	e&m	e&m	e&m	e&m	e&m	e&m	
R2 TYPE	n/a	n/a	n/a	n/a	n/a	n/a	n/a	n/a	
Rx TLP	0.0	0.0	0.0	0.0	0.0	0.0	0.0	0.0	
Tx TLP	0.0	0.0	0.0	0.0	0.0	0.0	0.0	0.0	
CODING	n/a	n/a	n/a	n/a	n/a	n/a	n/a	n/a	
TC CGA	idle	idle	idle	idle	idle	idle	idle	idle	
LB	off	off	off	off	off	off	off	off	
PATTRN	none	none	none	none	none	none	none	none	
HYBRID	n/a	n/a	n/a	n/a	n/a	n/a	n/a	n/a	
SIG CONV	n/a	n/a	n/a	n/a	n/a	n/a	n/a	n/a	
RATE	64K	64K	64K	64K	64K	64K	64K	64K	
ADPCM	n/a	n/a	n/a	n/a	n/a	n/a	n/a	n/a	

Save | Undo | Refresh | Copy | Test | Name | Main

Figure 5-40.E&M Provisioning screen

A new option has been added at the bottom of the screen, "Name". Hitting N for name takes the user to the screen shown below in Figure 5-41.

Node 121		U3 E&M 4Wx8ER Rev XC-0 Ser 00022						10-30-12 17:55	
page: 1 of 1		XC Name MENU							
Port	Name								
1									
2									
3									
4									
5									
6									
7									
8									

Refresh | pgUp | pgDn | Main

Figure 5-41.Name screen

From this screen, the user can name any of the eight DS0's with up to a fourteen character name. Special characters, numbers, lowercase and upper case characters are allowed. There is no checking, so the name can be used more then once on this card, or on any other card in the shelf.

5.19 Automatic Time Slot Assignment

You can automatically assign time slots to voice (E&M, FXS, etc.) cards by using the Configuration command in the System Main Screen. Figure 5-42 shows typical time slot assignments from four E&M cards to an E1 WAN port. The Configuration option automatically assigns the eight ports of E&M card 1 to time slots 1 through 8, seven ports of E&M card 2 to time slots 9 through 15, and all eight ports of E&M card 3 to time slots 17 through 24. Time Slots 25 through 31 are similarly assigned to E&M card 4, ports 1 through 7. Time Slot 16 is not assigned to any E&M card ports because it is reserved for channel-associated signaling (CAS) or common channel signaling (CCS) transmission on an E1 line.

For a T1 WAN port, the configuration command would assign time slots 1 through 8 to the eight ports of the first E&M card. Time Slots 9 through 16 would similarly go to the eight ports of a second E&M card, and time slots 17 through 24 would go to a third E&M card.

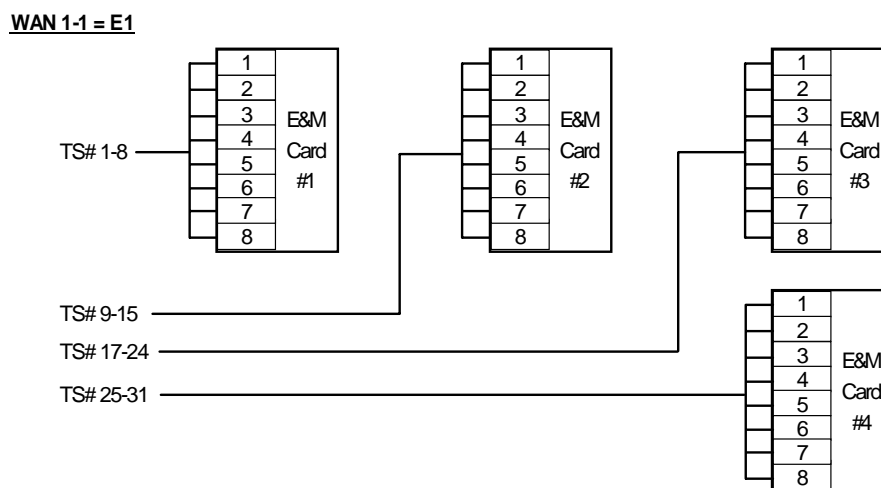

Figure 5-42. Automatic Time Slot Assignment Example

To use the Configuration command, first proceed as follows:

1. Make sure all voice cards you intend to configure are of the same type.
2. Place the cursor on the first user card slot that will have a card. In Figure 5-43, slots U5 through U8 will be assigned to 30 time slots on the E1 WAN port.
3. Press “c” to begin the configuration process.

4. Select the type of voice card from the types listed above the bottom line of the screen, as shown in Figure 5-43. In that screen, **e&m-6** is chosen as the card type (E&M, 600 ohms).

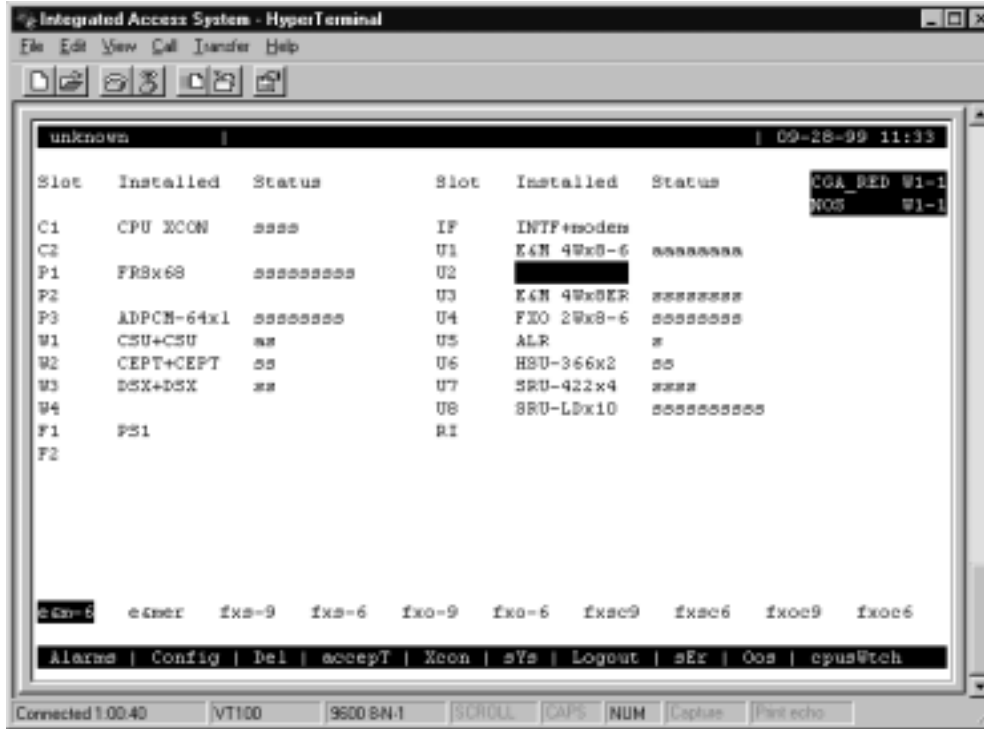

Figure 5-43. Typical Card Slot and Type Selection

5. Select the WAN port to which you want to assign the voice cards (W1-1 or W1-2), as shown in Figure 5-44.

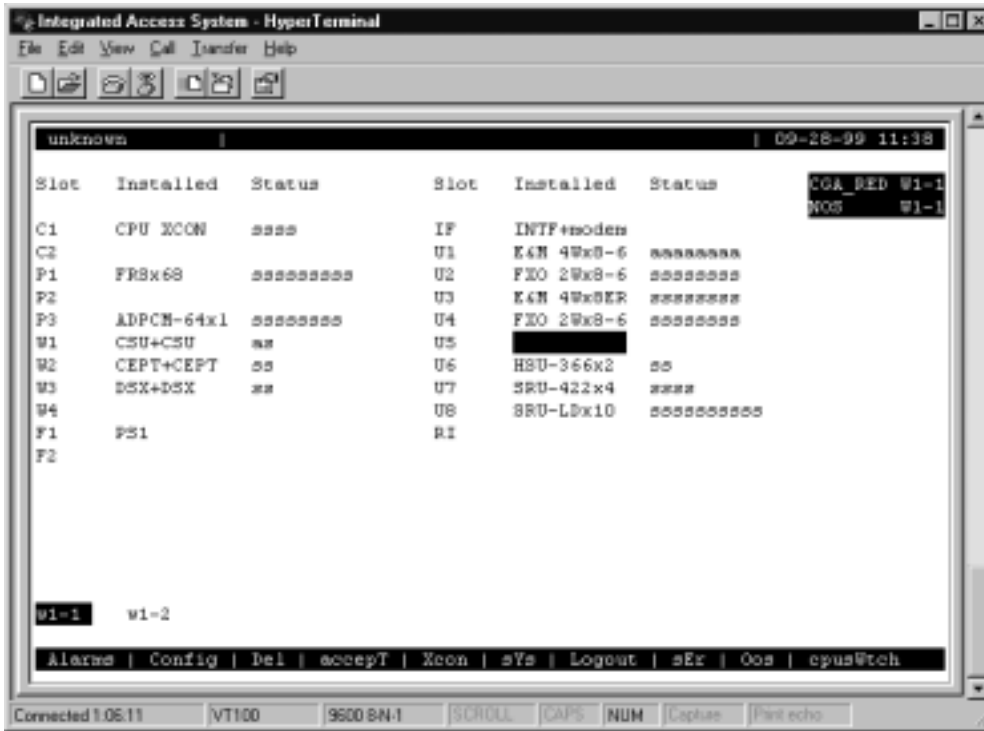

Figure 5-44. Typical WAN Card Selection

- The system automatically builds the necessary time slot structure. Since the user slots are vacant, the system will register Out Of Service (OOS) alarms for each of the four cards, as shown in Figure 5-45.

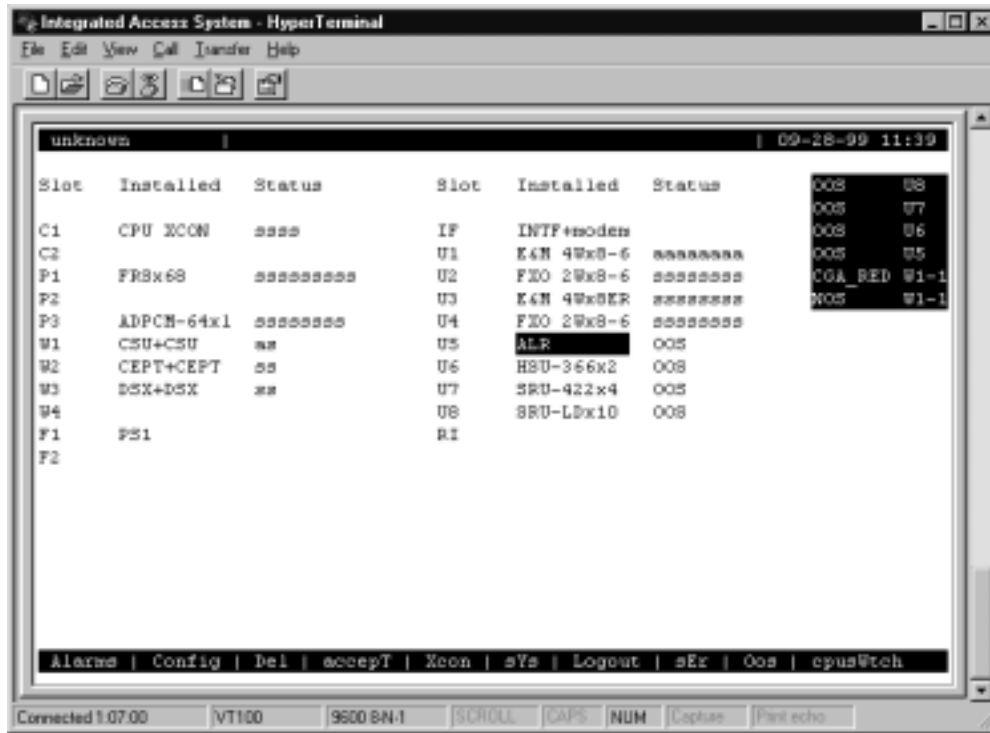

Figure 5-45. Typical System Main Screen with Alarms

- Insert the four voice cards into the chassis, to clear the OOS alarms.

Figure 5-46 shows the WAN Cross-Connect Screen with the correctly assigned time slots.

In Figure 5-46, the XCON column shows the user card slot and card port to which each time slot of the E1 line is assigned. Time Slot 16 is reserved for signaling (CAS), and time slot 0 is used for signal frame alignment.

TS	XCON	TS	CIRCUIT_ID	TS	XCON	TS	CIRCUIT_ID	OOS	U4
0		frame align	64k	16	cas		64k		
1	u1-1	A-01	user_circuit	17	u3-1	A-17	user_circuit	008	04
2	u1-2	A-02	user_circuit	18	u3-2	A-18	user_circuit	008	03
3	u1-3	A-03	user_circuit	19	u3-3	A-19	user_circuit	008	02
4	u1-4	A-04	user_circuit	20	u3-4	A-20	user_circuit	008	01
5	u1-5	A-05	user_circuit	21	u3-5	A-21	user_circuit		
6	u1-6	A-06	user_circuit	22	u3-6	A-22	user_circuit		
7	u1-7	A-07	user_circuit	23	u3-7	A-23	user_circuit		
8	u1-8	A-08	user_circuit	24	u3-8	A-24	user_circuit		
9	u2-1	A-09	user_circuit	25	u4-1	A-25	user_circuit		
10	u2-2	A-10	user_circuit	26	u4-2	A-26	user_circuit		
11	u2-3	A-11	user_circuit	27	u4-3	A-27	user_circuit		
12	u2-4	A-12	user_circuit	28	u4-4	A-28	user_circuit		
13	u2-5	A-13	user_circuit	29	u4-5	A-29	user_circuit		
14	u2-6	A-14	user_circuit	30	u4-6	A-30	user_circuit		
15	u2-7	A-15	user_circuit	31	u4-7	A-31	user_circuit		

Figure 5-46. Typical WAN Time Slot Assignment Screen

5.20 Cross-Connecting WAN Time Slots

After assigning the user cards to DS0 time slots, you can also assign the remaining WAN time slots for pass-through cross-connections between T1 and E1 links.

You can cross-connect WAN time slots from the System Main Screen. To perform cross-connections, press “x” in that screen to invoke the **Xcon** command. The CPU Cross-Connect Screen in Figure 5-47 appears. In the cross-connect screen, type “a” to add a cross-connect circuit. The **Add** command provides the fields used to program all of the "pass-through" circuits in the network (See Figure 5-48). Table 5-9 lists the circuit parameters and their options and default settings.

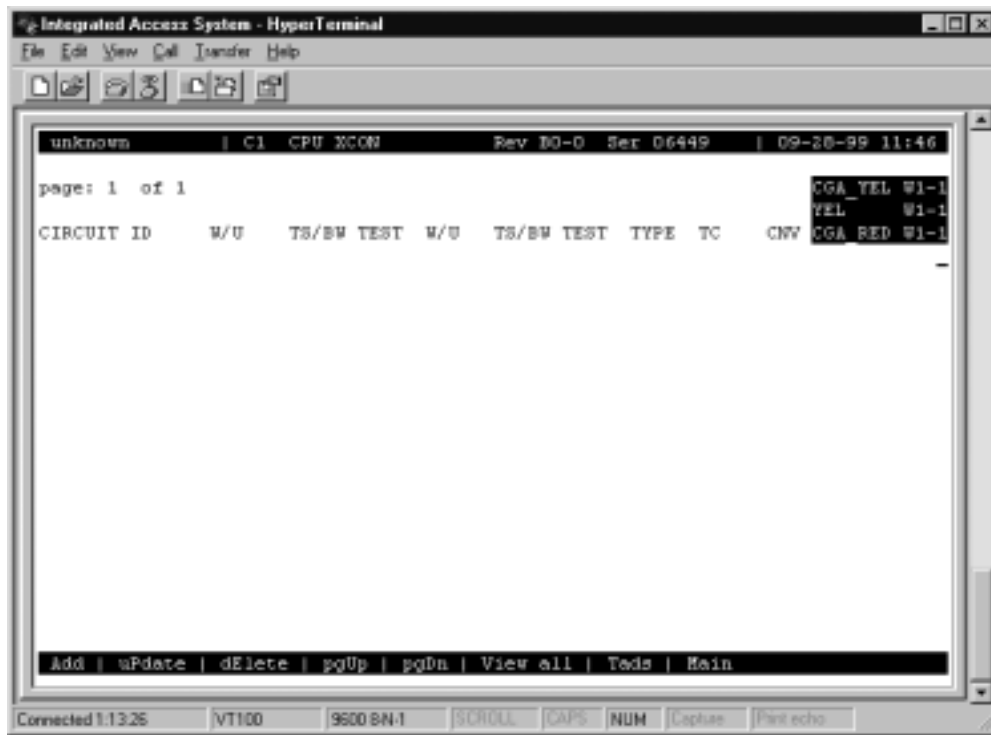

Figure 5-47. Typical CPU Cross-Connect Screen

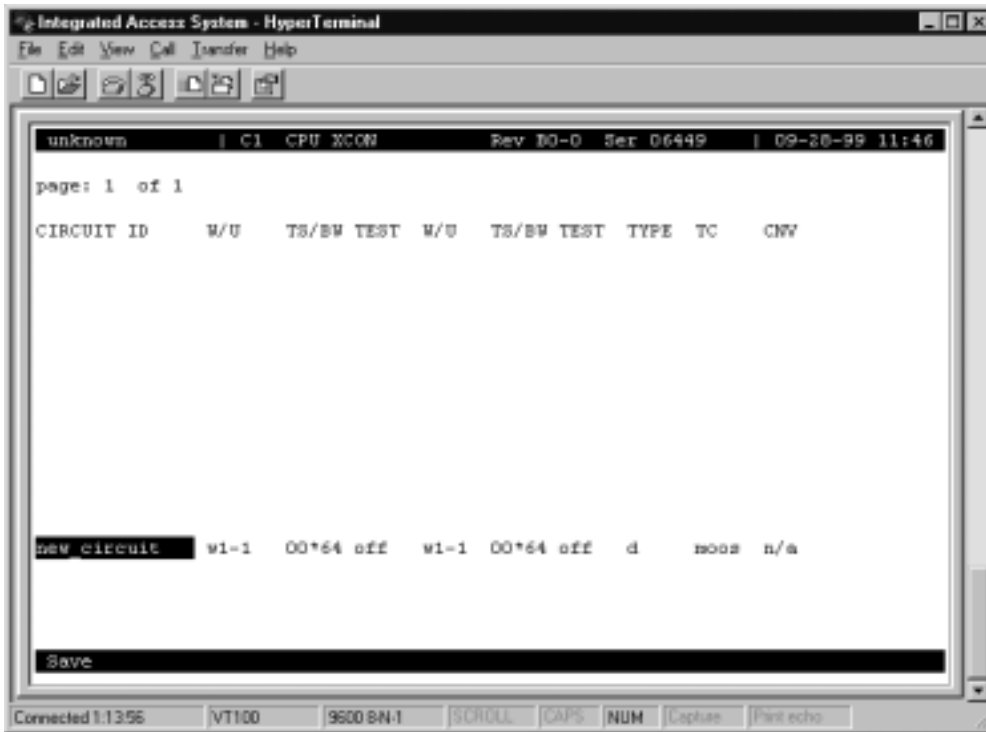

Figure 5-48. Add a Cross-Connect Circuit Screen

Table 5-9. Time Slot Cross-Connection Options and Defaults

Parameter	User Options	Default
CIRCUIT ID	Any combination of letters or numbers up to 14 characters, including spaces	*****
W/U	w1-1 w1-2 w2-1 w2-2 w3-1 w3-2 w4-1 w4-2	w1-1
TS/BW	table	00
TEST	off all0 all 1 m_oos 1:1 1:7 lpbk 300Hz 1KHz 3KHz	off
W/U	w1-1 w1-2 w2-1 w2-2 w3-1 w3-2 w4-1 w4-2	w1-1
TS/BW	table	00
TEST	off all0 all 1 m_oos 1:1 1:7 lpbk 300Hz 1KHz 3KHz	off
TYPE	v v&s d	d
TC		
v	n/a	no
v&s	e&m fxsl fxsg fxsd plar dpo fxol fxog fxod dpt user*(this selection will require a user-defined bit pattern) mrd	e&m
d	n/a	n/a
CNV		
PCM CONV	none A-mu mu-A	none
SIG CONV	none ANSI-CCITT CCITT-ANSI ABCD-ABAB ABCD-AB01	none

CIRCUIT ID

A *circuit* is defined as a group of one or more DS0 time slots cross-connected from one WAN link to another. Each circuit can carry either voice or data traffic, and needs its own name to facilitate cross-connect management within the system. The Circuit ID field allows you to name individual pass-through circuits. The factory-default ID is "new circuit." However, you can change the ID to show any relevant title for the pass-through connection, although each circuit ID must be unique. This ID can contain up to 14 numbers, letters (uppercase and lowercase), and spaces, in any combination. Figure 5-49 shows an example of a new circuit, which is named **SF01-NY01**.



WARNING!

When cross-connecting multiple independent data DS0 time slots (sequentially grouped time slots should work) for data. Super-rate [data type cross-connect] is multiple DS0s sequentially assigned between WAN aggregates in a cross-connect system. **DO NOT** attempt to save time by cross-connecting independent data time slots as one super-rate circuit (could cause data errors.) This limitation does not apply to voice time slots.



Figure 5-49. New Circuit Selection and ID Assignment

W/U

The first WAN Unit (W/U) column is the T1/E1 link in which the pass-through connection begins (since these circuits are bi-directional, the concept of beginning or ending is used for illustrative purposes only). The options are all WAN cards and ports, and the identification uses the same convention (**w1-1, w1-2, etc.**) seen earlier. If a WAN card is not present in the W/U selected, an error message is generated.

The example in Figure 5-50 shows **w1-1** (WAN 1, port 1) as the selected WAN card and port.

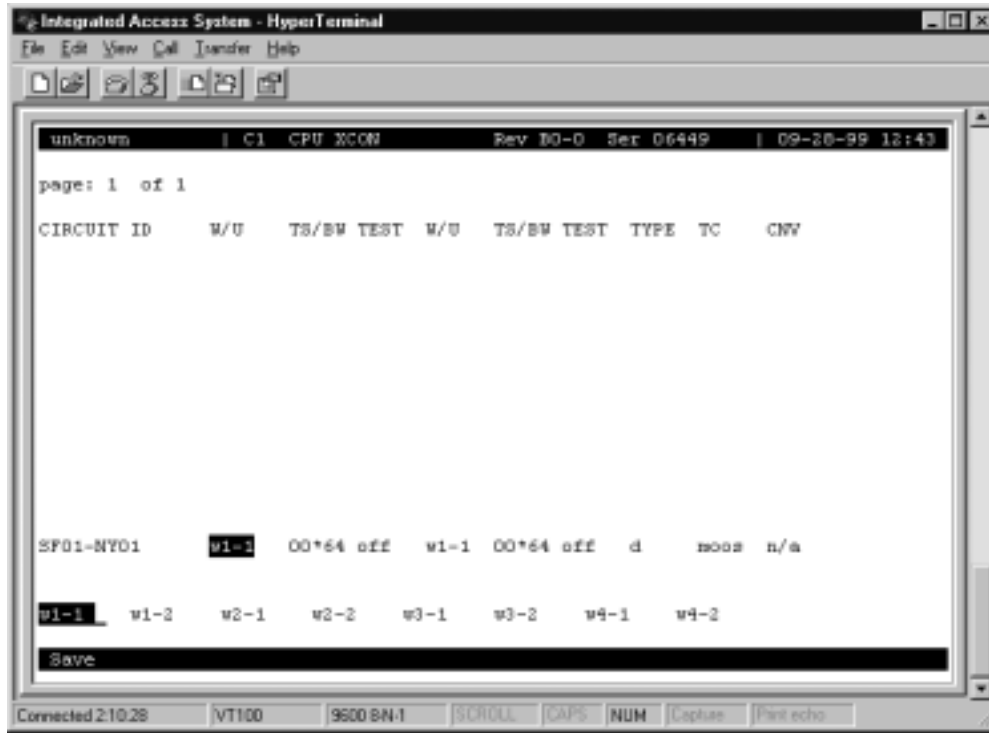

Figure 5-50. WAN Unit Options

TS/BW

The first Time Slot/Bandwidth column shows the different time slots of **w1-1** that will be assigned to this pass-through connection. Figure 5-51 shows the selection of time slots 8 to time slot 12 of **w1-1** assigned to the start of the connection. Any number of time slots from **1** to **24** is allowed for T1 transmission. Or, time slots **1** to **15** and **17** to **31** are allowed for E1 operations. *The bandwidth is automatically assigned.*

Make your selection by using the space bar and arrow keys. The arrow key moves from slot to slot, and the space bar toggles between selecting and deselecting a time slot.

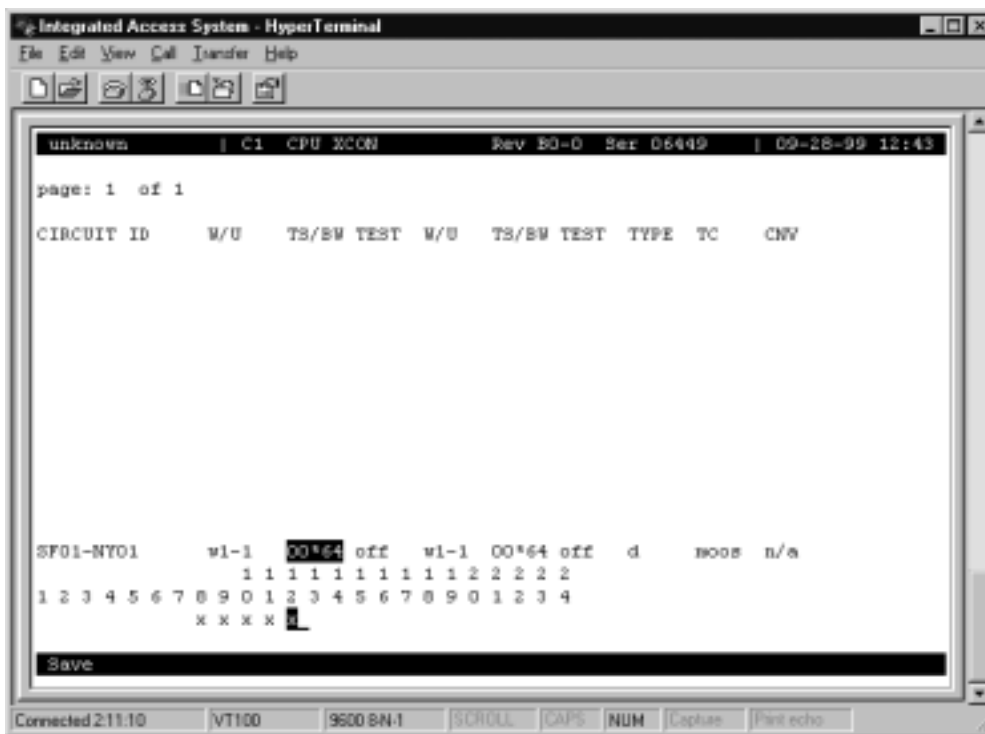

Figure 5-51. Time Slot and Bandwidth Options

TEST

The first Test column allows you to select the test pattern to be applied to this circuit in the direction of the first WAN link specified. Figure 5-51 shows the options, which you can select by highlighting the choice and pressing <Enter>. The choices are **off** (no testing); **all 0** (all zeros); **all 1** (all ones); **m_oos** (Multiplexer Out Of Sync); **1:1** ("one-to-one" pattern, where a 1 is followed by a zero); **1:7** ("one-to-seven" pattern, where a 1 is followed by seven zeros); **lpbk** (loopback); **300 Hz** (steady 300 Hz tone); **1KHz** (steady 1 kHz tone); and **3KHz** (steady 3 kHz tone).

When the circuit is saved, the system will send the selected pattern toward the first end of the circuit on each time slot, to facilitate testing. When circuit testing is finished, reset the Test field to the "off" position. The **lpbk** (loopback) option loops the circuit back toward the first WAN link specified.

If you have a voice cross-connect circuit (with or without signaling), you can access these capabilities from the WAN Cross-Connect Screen. See the review at the end of this section for more information.

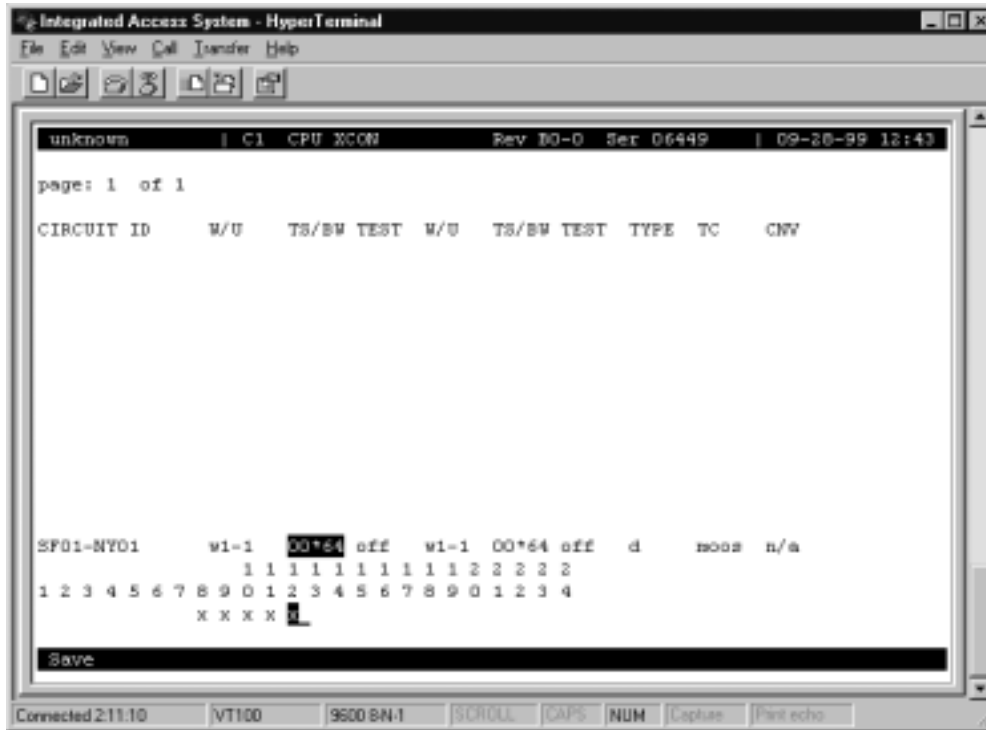

Figure 5-52. Test Options

W/U

The second WAN Unit column is the T1/E1 link in which the pass-through connection ends. The options are all of the WAN cards and ports. If a WAN card is not present in the W/U selected, an error message is generated. Figure 5-52 shows the selection of W 3-2.

TS/BW

The second Time Slot/Band Width column shows the different time slots from WAN 3-2 that will be assigned to this pass-through connection. Figure 5-52 shows the selection of 5 time slots from WAN 3-2 assigned to the end of the connection. Any number of time slots from **1-24** would be accepted for T1 operations and from **1-15 and 17-31** for E1 operations. The bandwidth is automatically assigned.

Make your selection with the space bar and arrow keys. The arrow key moves from slot to slot, and the space bar toggles between selecting and deselecting the time slot. *The number of DS0 time slots assigned to this half of the cross-connect circuit must equal the number assigned to the other. Otherwise, the system will reject the connections and generate an error message.*

TEST

The second Test column lets you select the test pattern to be applied to this circuit toward the second WAN link specified. Figure 5-52 shows the option set to **off**. Like the previous Test column, the choices are **off** (no testing); **all 0** (all zeros); **all 1** (all ones); **m_00s** (Multiplexer Out Of Synchronization); **1:1** (a 1 followed by one zero); **1:7** (a zero is followed by a 1 and six more zeros); **lpbk** (loopback); **300 Hz** (steady 300 Hz tone); **1KHz** (steady 1 kHz tone); and **3KHz** (steady 3 kHz tone).

When the circuit is saved, the system will send the selected pattern toward the second end of the circuit on each time slot, to facilitate testing. When circuit testing is finished, reset the Test field to **off**. The Loopback (**lpbk**) option loops the circuit back toward the first WAN link specified.

Users dealing with a voice cross-connect circuit (with or without signaling) can access capabilities from the WAN cross-connect screen. See the review at the end of this section.

TYPE

The Type column selects the type of pass-through circuit, as shown in Figure 5-52. The choices are **v** (voice); **v&s** (voice with signaling), and **d** (data). Use **v** for a voice circuit that does not require trunk conditioning. Use **v&s** for a voice circuit with signaling. This option preserves A/B (robbed-bit) signaling on the selected time slots and provides trunk conditioning. Use **d** for data circuits, which also support trunk conditioning.

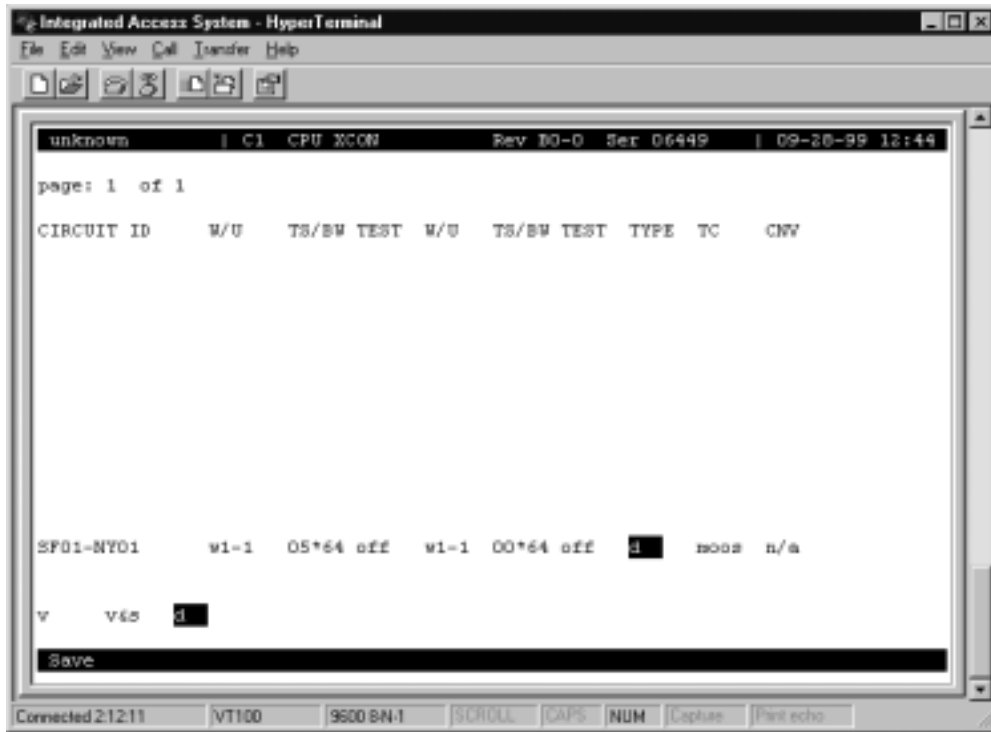

Figure 5-53. Cross-Connect Circuit Type Selection

TC

You can define the pattern to be transmitted on a cross-connected circuit if one of the circuit's two WAN links fails. This is known as Trunk Conditioning (TC), and the available selections depend on the Type column setting.

If the Type setting is **d** (data), no TC choice is available and the system automatically shows **moos**. An example of this is shown as Figure 5-53.

If the Type setting is **v&s** (voice with signaling), the TC choices are shown in Figure 5-54. They are as follows: **user** (user-defined bit pattern), **e&m** (trunk signaling), **fxsl** (foreign exchange station-loop-start), **fxsg** (foreign exchange station ground-start), **fxsd** (foreign exchange station-defined network), **plar** (private-line automatic ringdown), **dpo** (dial-pulse originating), **fxol** (foreign exchange office loop-start), **fxog** (foreign exchange office ground-start), **fxod** (foreign exchange office-defined network), **dpt** (dial-pulse terminating) and **mrd** (manual ringdown).

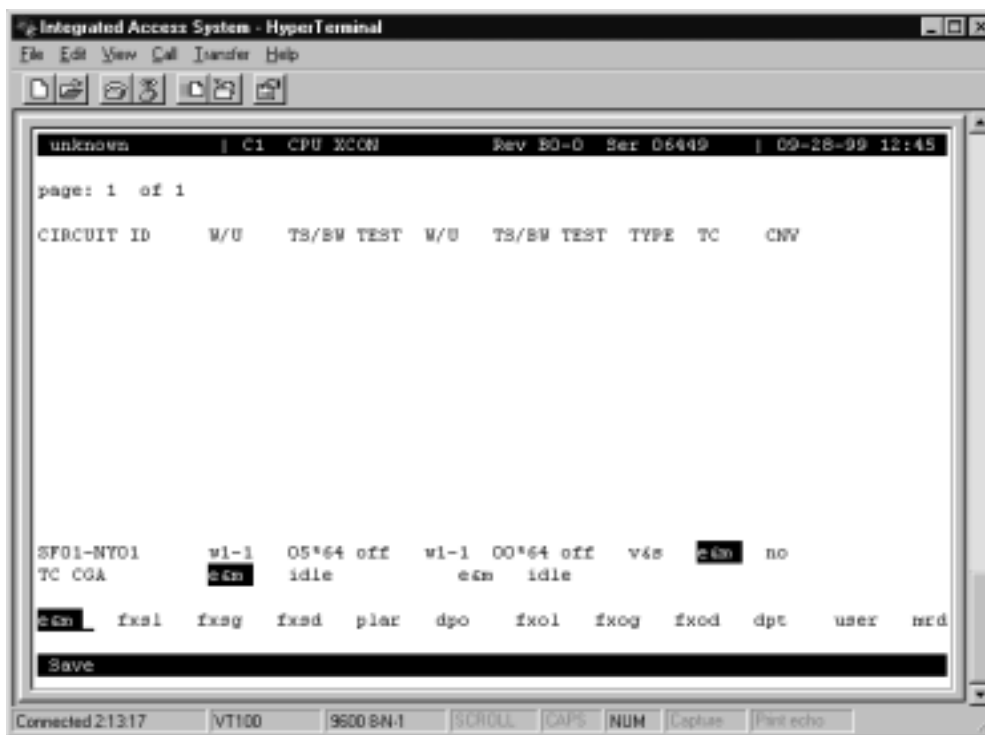

Figure 5-54. Trunk Conditioning Option Selection

When utilizing the TC function, care should be taken to ensure that on intermediate (pass-through) nodes, that the proper signaling is represented on the WAN to WAN cross-connect. In the case of an FXO to FXS circuit, the WAN to WAN pass-through circuits

should have FXS signaling set on the FXO side, and FXO signaling on the FXS side. In this way, should a T1 be out of service, the proper trunk conditioning will be sent to the PBX or switch.

If you choose **user**, also enter a two-digit hexadecimal code for the bit pattern to be sent in each direction. Each digit can be from **0** to **9** or **a** to **f**. Figure 5-55 shows a typical signaling bit pattern entry screen.

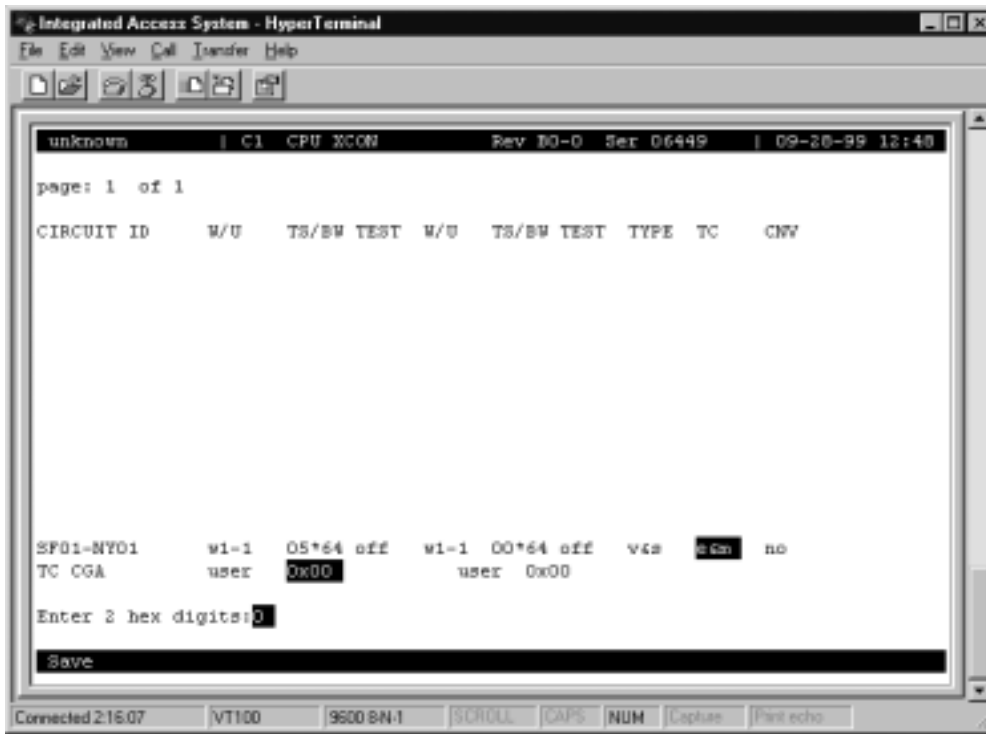

Figure 5-55. Signaling Bit Pattern Selection

For **v** (voice), no TC choice is available, so the system always shows **n/a** (not applicable). This is shown as Figure 5-56.

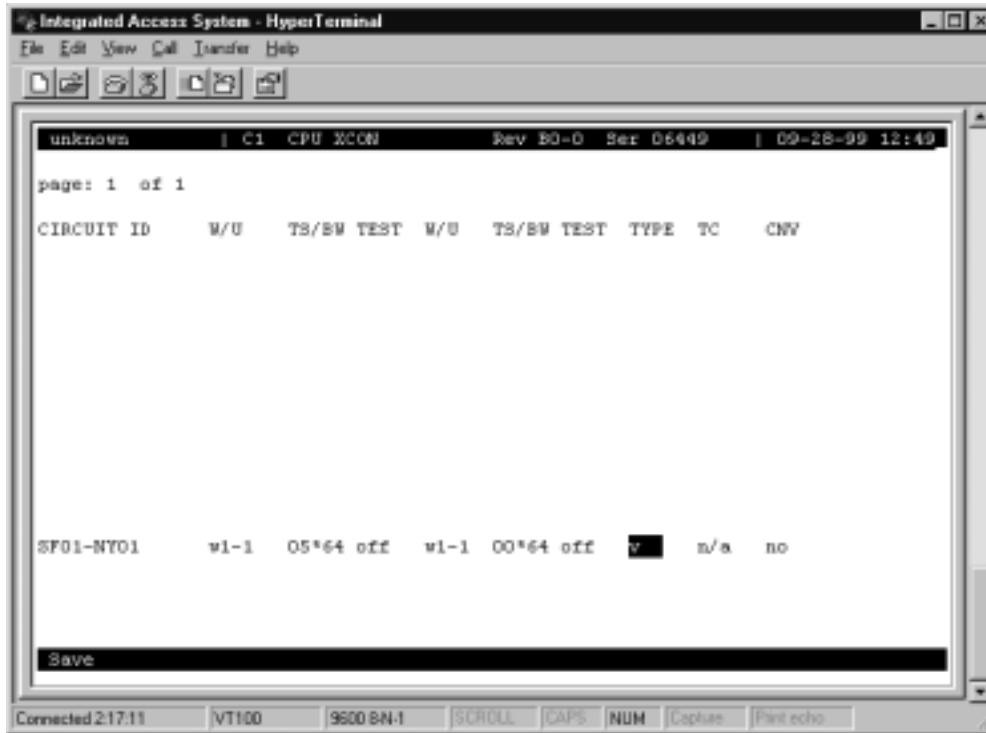

Figure 5-56. Voice Options Screen

CNV

The Conversion (CNV) parameter allows you to request that PCM companding and signaling conversion be performed on this cross-connect circuit. Since these conversions only apply to voice circuits, if the TYPE selected is **d** (data), then the only acceptable value here is **n/a**. Similarly, if the TYPE selected is **v** (voice without signaling), the system will only allow users to request PCM companding conversion. If the TYPE is **v&s** (voice with signaling), then users can select any combination of companding and/or signaling conversion.

If the TYPE is **v** or **v&s**, the system will first ask users to "Select PCM CONV:" for defining the type of companding conversion users require (see Figure 5-57). The options are no companding conversion (**none**), convert the incoming **A-mu** (A-law signal to mu-law) and convert the incoming **mu-A** (mu-law signal to A-law).

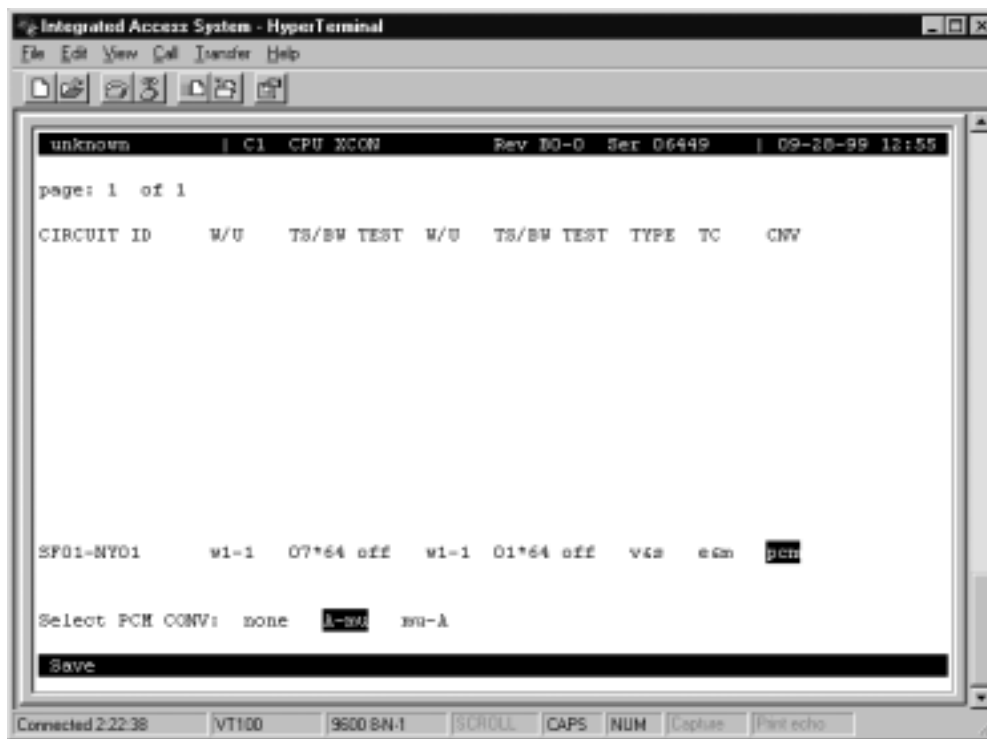

Figure 5-57. Selecting PCM Conversion

If the TYPE is **v&s**, the system will prompt users to "Select SIG CONV:" for selecting the type of signaling conversion needed (see Figure 5-58). The option **none** (default signaling conversion) is where a bit pattern of "0000" will automatically be converted to "0001" in the T1-to-CEPT E1 direction.

The **ANSI-CCITT** setting will convert the incoming ANSI signaling to CCITT signaling. Conversely, the **CCITT-ANSI** setting will convert the incoming CCITT signaling to ANSI signaling. These two options are complementary (i.e., if either is selected in one direction, the other is automatically selected for the reverse direction).

The **ABCD-ABAB** setting will convert the incoming CEPT signaling to T1 signaling for an ESF or D4 cross-connect. The **ABCD-AB01** option will convert the incoming T1 signaling to CEPT signaling for an ESF or D4 cross-connection. These two options are complementary (if either one is selected in one direction, the other is automatically selected for the reverse direction).

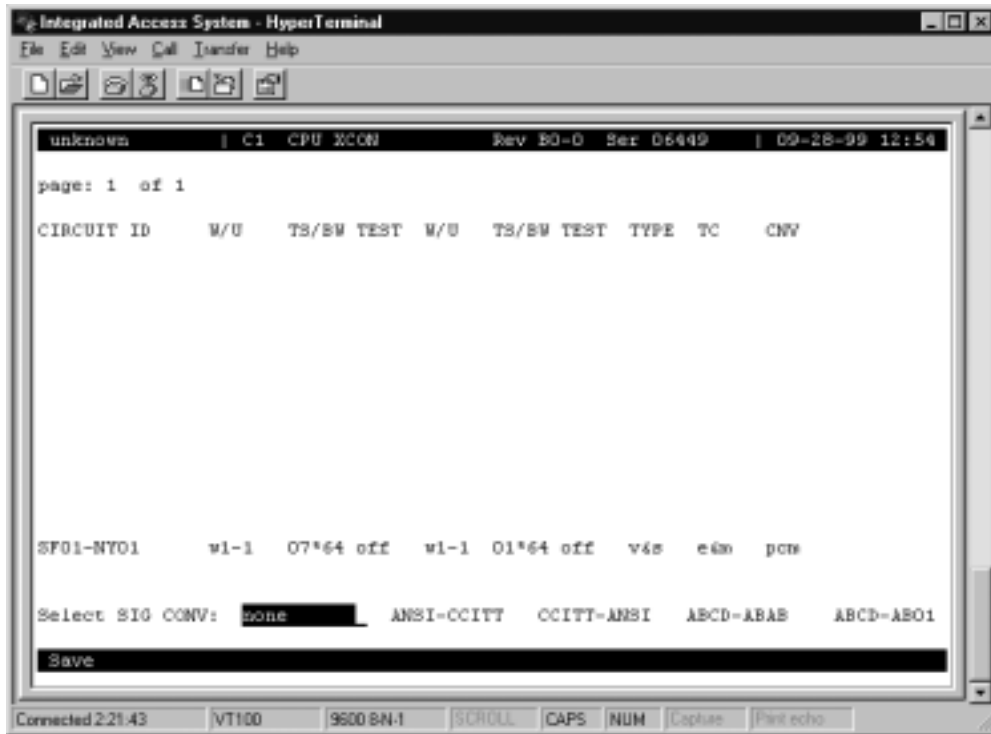
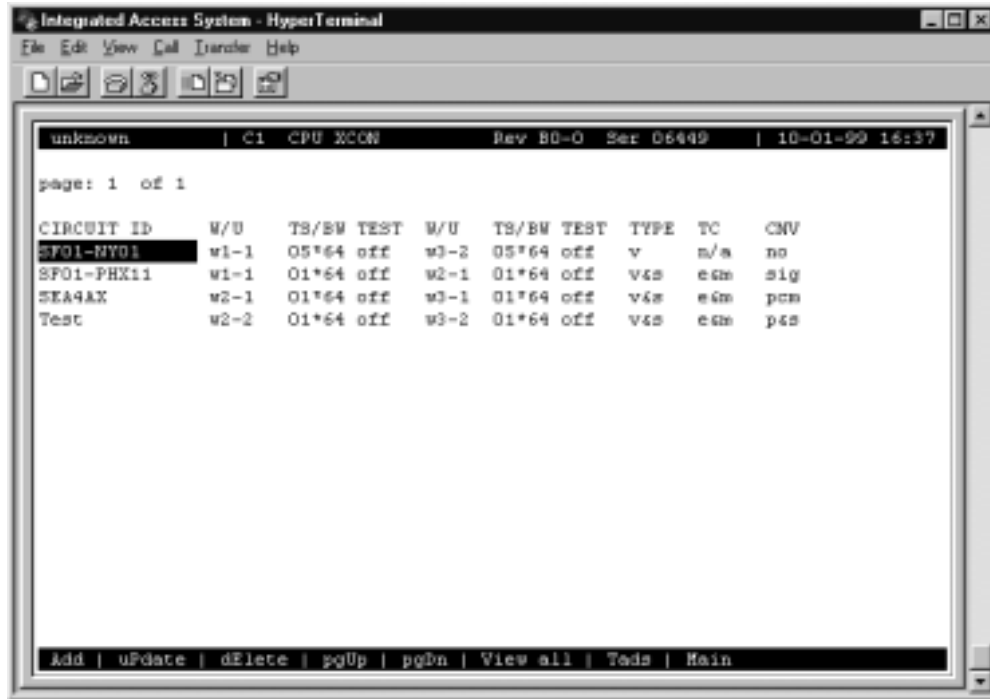

Figure 5-58. Selecting Signaling Conversion

Due to space limitations in the CNV column on the screen, the system will display a summary notation of the choices just made. The possible values are **no** (no conversion), **sig** (signaling is converted, but not the PCM), **pcm** (PCM is converted, but not the signaling) and **p&s** (both signaling and PCM are converted). Figure 5-59 shows those options.



The screenshot shows a HyperTerminal window titled "Integrated Access System - HyperTerminal". The window contains a table of circuit information. The table has columns for Circuit ID, W/U, TS/BW, TEST, W/U, TS/BW, TEST, TYPE, TC, and CNV. The rows represent different circuits: SFO1-NY01, SFO1-PHX11, SEA4AX, and Test. The CNV column shows the conversion status for each circuit.

CIRCUIT ID	W/U	TS/BW	TEST	W/U	TS/BW	TEST	TYPE	TC	CNV
SFO1-NY01	w1-1	05*64	off	w3-2	05*64	off	v	m/a	no
SFO1-PHX11	w1-1	01*64	off	w2-1	01*64	off	v&s	e&m	sig
SEA4AX	w2-1	01*64	off	w3-1	01*64	off	v&s	e&m	pcm
Test	w2-2	01*64	off	w3-2	01*64	off	v&s	e&m	p&s

Figure 5-59. Typical Completed Circuits

5.21 Cross-Connect Actions

Table 5-10 summarizes the actions you can perform from the CPU Cross-Connect Screen. These actions appear at the bottom highlighted line of the screen.

Table 5-10. CPU Cross-Connect Screen Actions

Action	Function
Add	Allows you to program additional pass-through cross-connects in the system. If mistakes are made during the add process, pressing the up arrow or down arrow key will terminate this operation.
uPdate	Initiated by pressing the "p" key. With this command, users can change any of the parameters of a pass-through connection. Use the arrow keys to highlight the area to be changed and close the transaction using the "s" (Save) command.
dElete	Initiated by pressing the "e" key. Use this command to delete existing pass-through connections. The system will prompt users to delete the circuit, and the "y" key must be pressed to complete the transaction.
pgUp	Initiated by pressing the "u" key. Since the system can handle many different cross-connect circuits, users may exceed a single screen. New pages will be added automatically to accommodate additional circuits. The page count feature at the top of the screen shows the current page and the total amount of cross-connect pages. Use this command to scroll up through the pages of cross-connect information.
pgDn	Initiated by pressing the "d" key. This action is similar to the pgUp command. Use this command to scroll down through the pages of cross-connect information.
View all	The View all action is initiated by pressing the "v" key. This action is used to access the Broadcast screen discussed in a later section.
Tads	Test Access Digroups is a remote test access for data cross connects that pass through the system.
Save	Once the pass-through connection is defined, pressing "s" (Save) will cause the circuit to be established and will update the WAN cards involved.

To update a cross-connected circuit from the CPU Cross-Connect Screen, highlight the circuit name to be updated, and press “p” to invoke the **uPdate** command. Figure 5-60 shows the WAN card in TS (time slot) 8 through 12 being updated. However if the WANs are selected and deleted as shown in Figure 5-61 then the screen in Figure 5-60 will be blank for WAN TS 8 through 12.

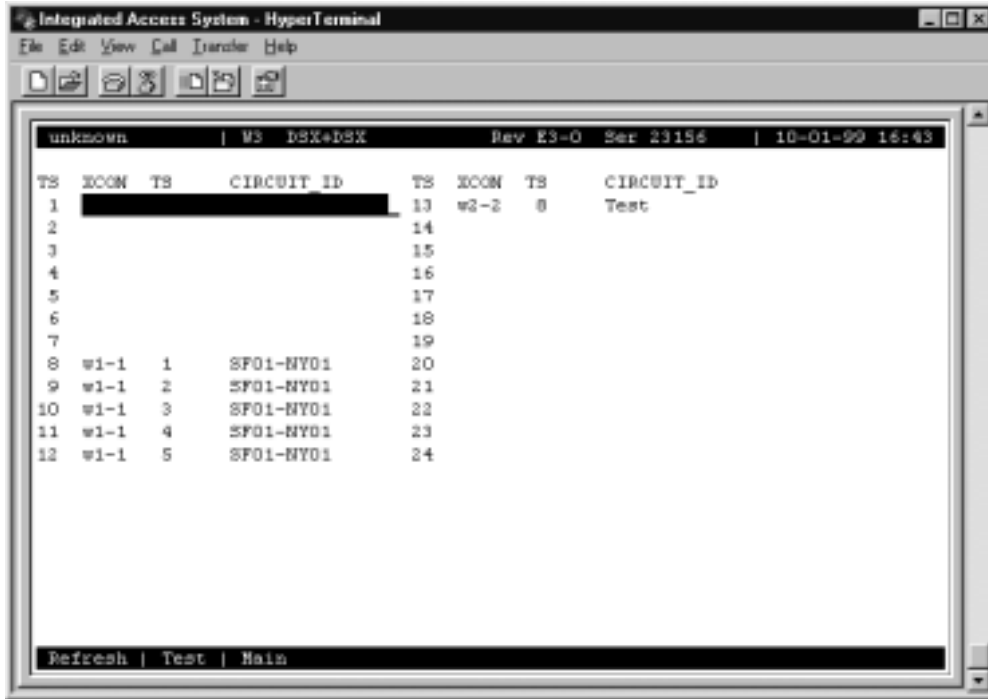

Figure 5-60.Updated WAN Card Screen

To delete a cross-connected circuit from the CPU Cross-Connect Screen, highlight the circuit name to be deleted, and press “e” to invoke the **dElete** command. Figure 5-61 shows the deletion process.

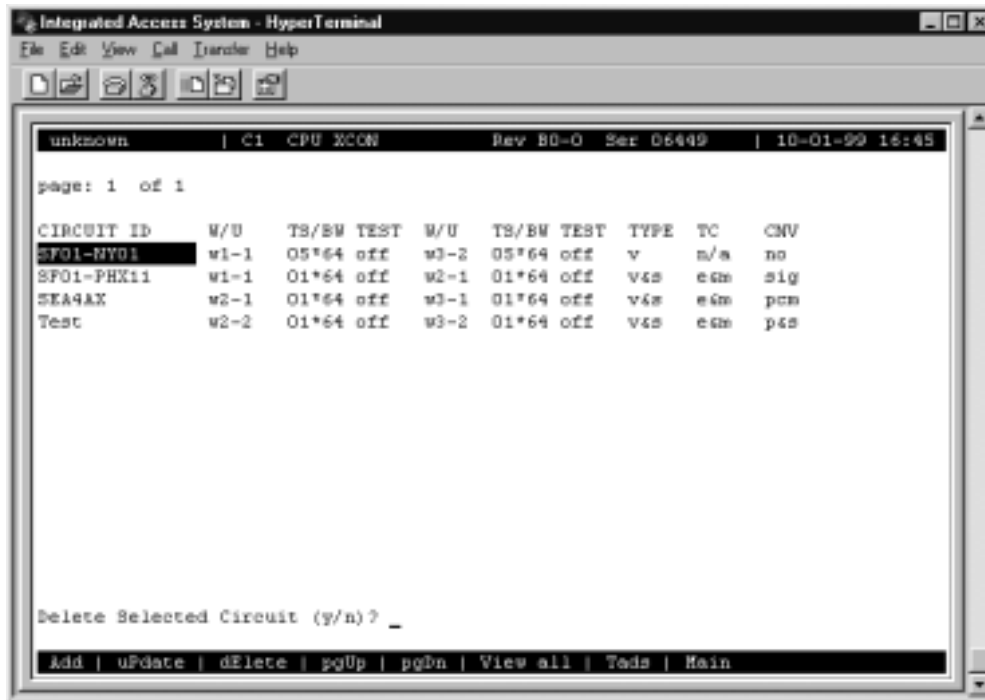
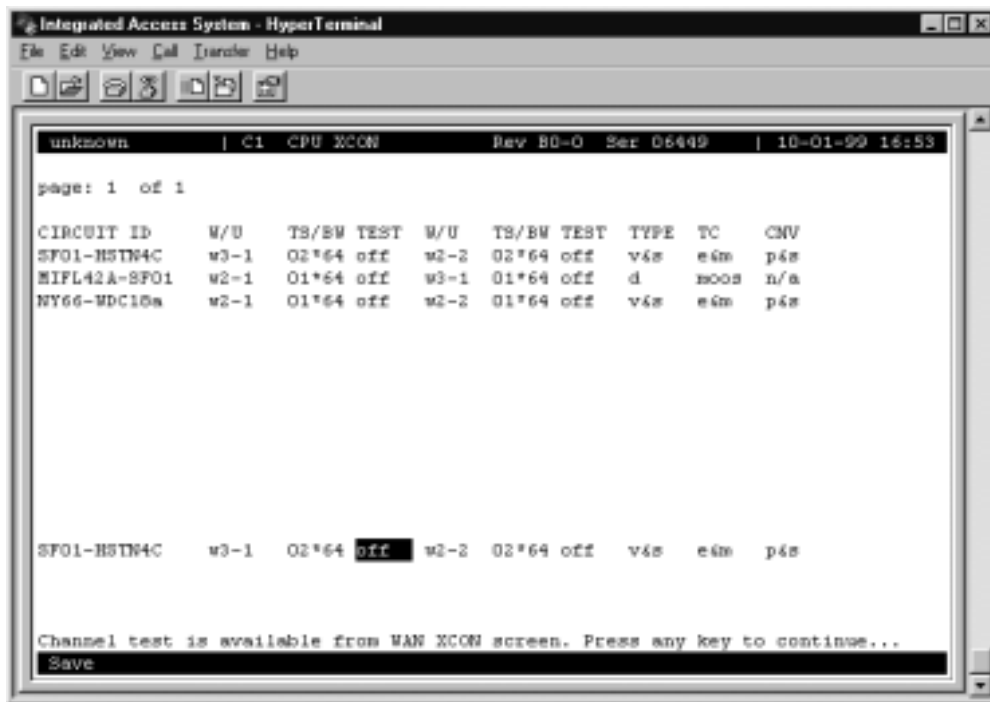

Figure 5-61.Delete Cross-Connection Screen

5.22 Testing Voice Cross-Connects

Voice and data circuits differ in the way the test function is accessed. While you can set up test patterns on data circuits on the cross-connect screen from the System Main Screen, you must use a subscreen of the WAN Cross-Connect Card Screen for circuit testing. Figure 5-62 shows the error message that appears when you attempt to test voice circuits from the CPU Cross-Connect Screen.



```
Integrated Access System - HyperTerminal
File Edit View Call Transfer Help
[Icons]
unknown | C1 CPU XCON Rev B0-0 Ser 06449 | 10-01-99 16:53
page: 1 of 1
CIRCUIT ID W/U TS/BW TEST W/U TS/BW TEST TYPE TC CMV
SF01-HSTN4C w3-1 02*64 off w2-2 02*64 off v4s e6m p4s
MIFL42A-SF01 w2-1 01*64 off w3-1 01*64 off d m00s n/a
NY66-WDC18a w2-1 01*64 off w2-2 01*64 off v4s e6m p4s

SF01-HSTN4C w3-1 02*64 dif w2-2 02*64 off v4s e6m p4s

Channel test is available from WAN XCON screen. Press any key to continue...
Save
```

Figure 5-62. Typical Message on a CPU Cross-Connect Screen

Figure 5-63 shows the WAN Cross-Connect Screen for the voice circuit used in this example. Place the cursor over the selected circuit and press the "t" key to bring up the Test Screen shown in Figure 5-64. This screen now splits the circuit into two parts, with the location acting as the midpoint. The first column of test parameters will apply to that portion of the circuit on port w2-1, time slot 13. The second column of test parameters will apply to that portion of the circuit on port w2-2, time slot 13.

Table 5-11 lists the test parameters and their available and default values.

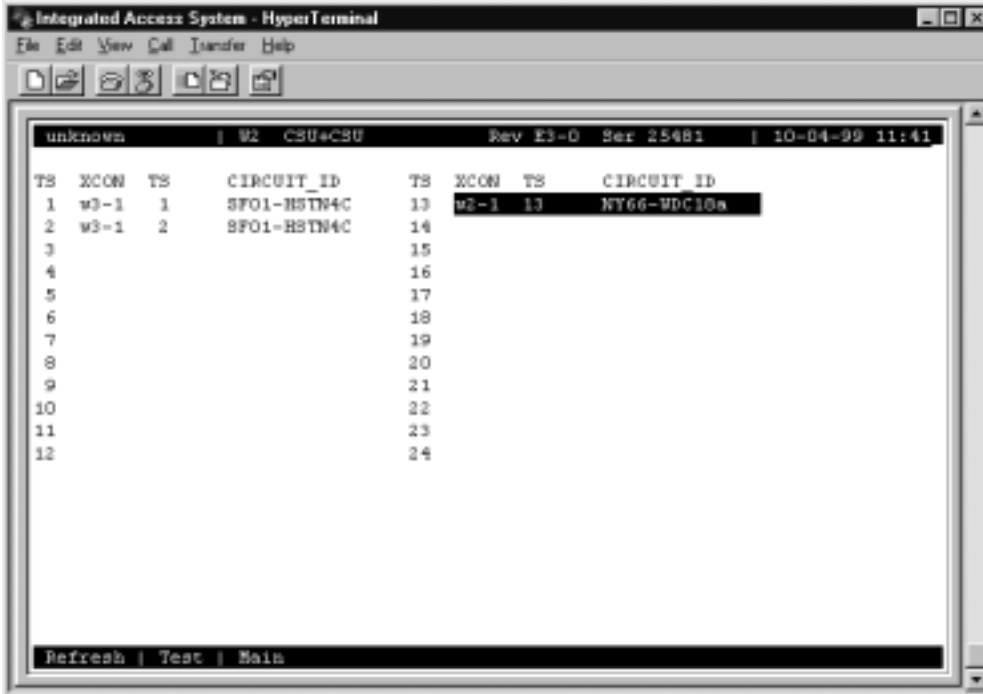

TS	XCON	TS	CIRCUIT_ID	TS	XCON	TS	CIRCUIT_ID
1	w3-1	1	SF01-HSTN4C	13	w2-1	13	NY66-WDC10a
2	w3-1	2	SF01-HSTN4C	14			
3				15			
4				16			
5				17			
6				18			
7				19			
8				20			
9				21			
10				22			
11				23			
12				24			

Refresh | Test | Main

Figure 5-63. Highlighted Circuit on a WAN Cross-Connect Screen



Figure 5-64. Typical Test Screen and ABCD Bit Options

Table 5-11. WAN Cross-Connect Test Screen Options

Parameter	User Options	Default
Tx ABCD	mon set	mon
PATTERN	off all0 all1 m_oos 1:1 1:7 lpbk 300Hz 1KHz 3KHz	off
MON Tx ABCD	information only—no user options	
MON Rx ABCD	information only—no user option	
CONVERSION	information only—no user option	
TYPE	information only—no user option	
WAN STATE	information only—no user option	

Tx ABCD BITS

The Transmit ABCD bit parameter has two options: **mon** (allowing you to observe the bit pattern being sent on the transmit side of the line), and **set** (to choose a different pattern for testing that portion of the circuit). Choosing **set** brings up a small four-character window at the bottom of the screen, where you can type in a new pattern of ones and zeros.

Figure 5-65 shows a diagram of the test process. When Tx ABCD for w2-1 is set to **mon**, the w2-1 column reflects the ABCD bits being sent out on w2-1. This pattern should be identical to Rx ABCD on w2-2, unless the conversion table is used. When Tx ABCD for w2-1 is optioned to **set**, users supplies a bit pattern of four 1s and 0s for the new ABCD bits. The Rx ABCD stream from w2-2 is broken at circle #1, and the new pattern is inserted into the Tx ABCD stream. The same applies for **mon** and **set** for w2-2. The bitstream will be broken at circle 2.

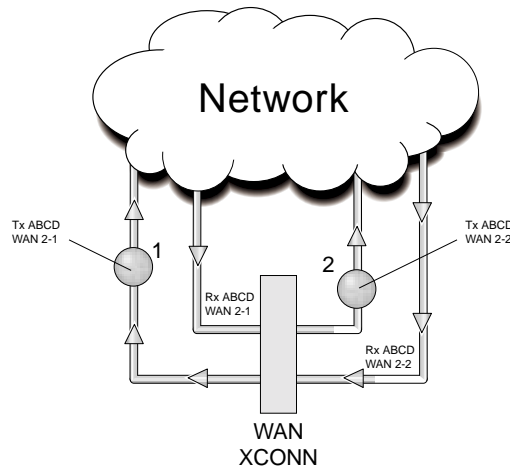

Figure 5-65.Voice Test Diagram

PATTERN

The Pattern parameter allows you to choose a test pattern to be transmitted as PCM data on the selected side of the circuit. The options are **off**, **all 0** (zero), **all 1** (one), **m_oos** (multiplexer out of synchronization), **1:1** (a 1 followed by a zero and then another 1), **1:7** (a zero followed by a 1 and seven zeros, then another 1), **lpbk** (loopback), **300 Hz** (300 Hz tone), **1KHz** (1 kHz tone) and **3KHz** (3 kHz tone). Since Tx ABCD only changes signaling bits, this option allows you to choose the test pattern. You can send a different pattern toward either side of the circuit.

Mon Tx ABCD

The Monitor Transmit ABCD bit information field shows the ABCD bit pattern being transmitted on the outbound circuit. You can change it by using the **set** command. *This parameter is for information only.*

Mon Rx ABCD

The Monitor Receive ABCD bit information field allows you to observe the bit pattern being received on the inbound circuit. *This parameter is for information only; you cannot change it.*

CONVERSION

The Conversion information field shows users the conversion setting selected from the cross-connect screen. The possible values are **no** (no conversion), **sig** (signaling is converted, but not the PCM), **pcm** (PCM is converted, but not the signaling) and **p&s** (both signaling and PCM are converted). *This parameter is for information only; you cannot change it.*

TYPE

The Type information field show you the type of circuit (**v** for voice or **v&s** for voice and signaling).

WAN STATE

The WAN State information field shows the current status of the port. The possible values are **stdby**, **actv**, **test** (the user is actively controlling the circuit), **OOS** (WAN port is Out of Service), and **CGA** (WAN port has a CGA alarm). *This parameter is for information only; you cannot change it.*

5.23 Using the Broadcast Option

One of the special features of WAN time slot assignment in cross-connect systems is the ability to copy a data signal and send it to multiple locations without disturbing the original circuit. This feature is called *broadcasting*, which means “multi-cast” (not to be confused with broadcast-quality video transmission).

For example, assume that a major company has a video lecture transmitted from the corporate headquarters in Denver to the sales office in San Francisco. The sales offices in Salt Lake City, Houston, and Phoenix would also like to view the lecture.

The master circuit (Denver to San Francisco) is a two-way circuit (i.e., both ends can send and receive data). The other ends of the broadcast circuits (the sales offices in Salt Lake City, Houston and Phoenix) will only be able to receive the output of the Denver end of the master circuit. That is, they will not be able to participate in the live discussion.

The following series of figures shows how the process works.

Figure 5-66 shows the Main Cross-Connect screen. In this example, T1 circuits connected at the Denver office go to San Francisco (**w1-1**), Houston (**w1-2**), Salt Lake City (**w2-1**), and Phoenix (**w2-2**).



Note: The screen only shows the cross-connects made from WAN cards to WAN cards, not from user cards to WAN cards.

```
unknown | C2 CPU XCON Rev B0-0 Ser 06345 | 10-04-99 11:49
page: 1 of 1
CIRCUIT ID W/U TS/BW TEST W/U TS/BW TEST TYPE TC CNV
SF-SLC w1-1 01*64 off w2-1 01*64 off v m/a no
RST-PHX w1-2 01*64 off w2-2 01*64 off v m/a no
Add | uPdate | dElete | pgUp | pgDn | View all | Teds | Main
```

Figure 5-66. Typical Main Cross-Connect Screen

Broadcast circuits can be initiated, updated, or deleted only from the broadcast screen.

To access the Broadcast option, press "v" (for **View all**) in the Main Cross-Connect Screen. The All Circuits Screen of Figure 5-67 appears. In addition to the WAN card-to-WAN card cross-connects, this screen also shows all user card-to-WAN card time slot assignments **for all WAN cards**.

Because this screen shows all WAN time slots that are either assigned to user cards or cross-connected to other time slots, it may be filled with data.

```

unknown | C2 CPU XCON Rev B0-0 Ser 06345 | 10-04-99 12:02
page: 1 of 1
CIRCUIT ID  W/U  TS/BW TEST  W/U  TS/BW TEST  TYPE  TC  CNV
SF-SLC      w1-1  01*64 off   w2-1  01*64 off   v     n/a  no
RST-PHX     w1-2  01*64 off   w2-2  01*64 off   v     n/a  no
new_circuit w4-1  06*64 off   w1-1  06*64 off   d     noos n/a
new_circuit w4-2  06*64 off   w2-2  06*64 off   d     noos n/a
Beast | uPdate | dElete | pgUp | pgDn | Main

```

Figure 5-67. Typical All Circuits Screen

In addition to the two WAN-to-WAN cross-connects shown in Figure 5-66, an HSU circuit from slot U4-1 to the San Francisco T1 circuit (on WAN 1-1), and an HSU circuit from slot U4-2 to Phoenix (on WAN 2-2) are shown in Figure 5-67.

To select the broadcast option, place the cursor over the User card circuit that will be copied. In this case, it will be the Denver end of the Denver-to-San Francisco link on WAN 1-1. Then, press the "b" (**Bcast**) key from the actions at the bottom of the screen.

The screen of Figure 5-67 shows the dynamics of the first copy of that circuit. Press the <Enter> key to access and modify the connection options.



Figure 5-68. Typical Add Broadcast Screen

In this example, the broadcast circuit is named "Lecture" for easier identification later, when the circuit will be disconnected.

Figure 5-68 shows the selection of a second destination for the broadcast circuit. In that example, that destination is Salt Lake City, which is accessed through **w2-1**. The time slot selection is shown in Figure 5-68. Press "**s**" (**Save**) to save the parameters of the new circuit. Figure 5-71 shows the new circuit, whose type is **b/d** (broadcast/data).

Use similar actions to duplicate this circuit for the other destinations. Figure 5-69 shows the completed circuits.

To disconnect the circuits when the program is finished, highlight the circuit to be disconnected and press the "e" key. The screen shown in Figure 5-73 will appear. Then, select "y" to permanently delete the copied circuit while leaving the original circuit intact.

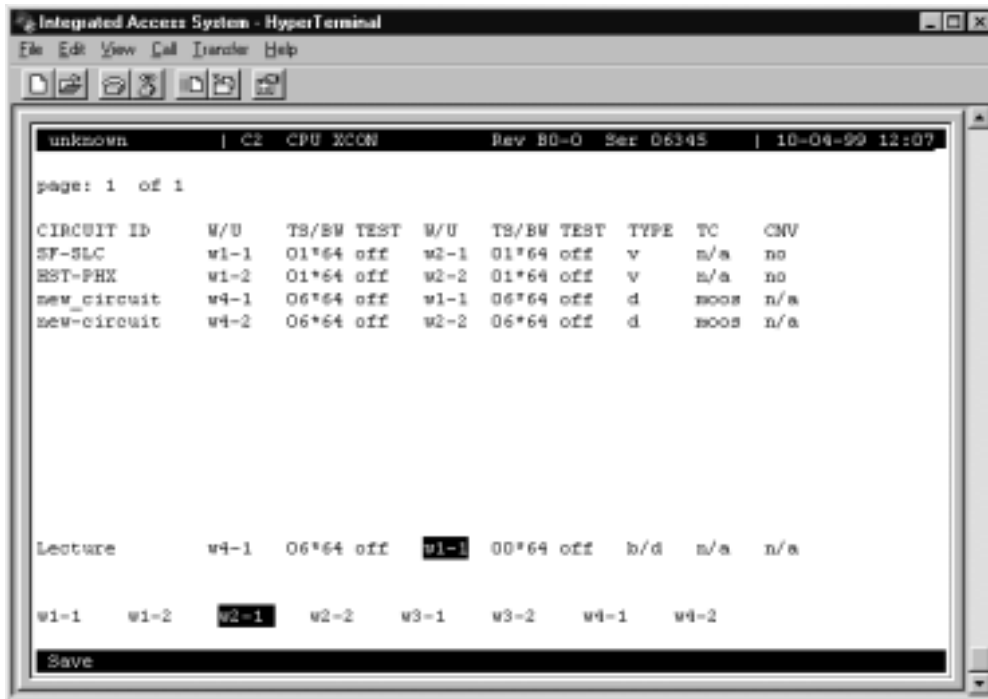

Figure 5-69. Typical "To" Destination Selection

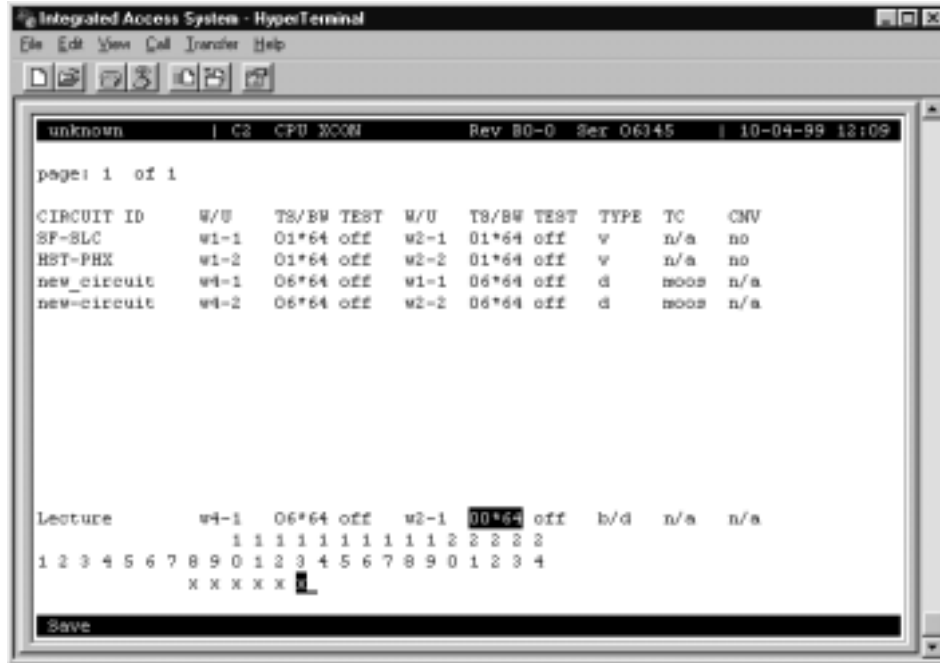

Figure 5-70. Typical Time Slot Selection

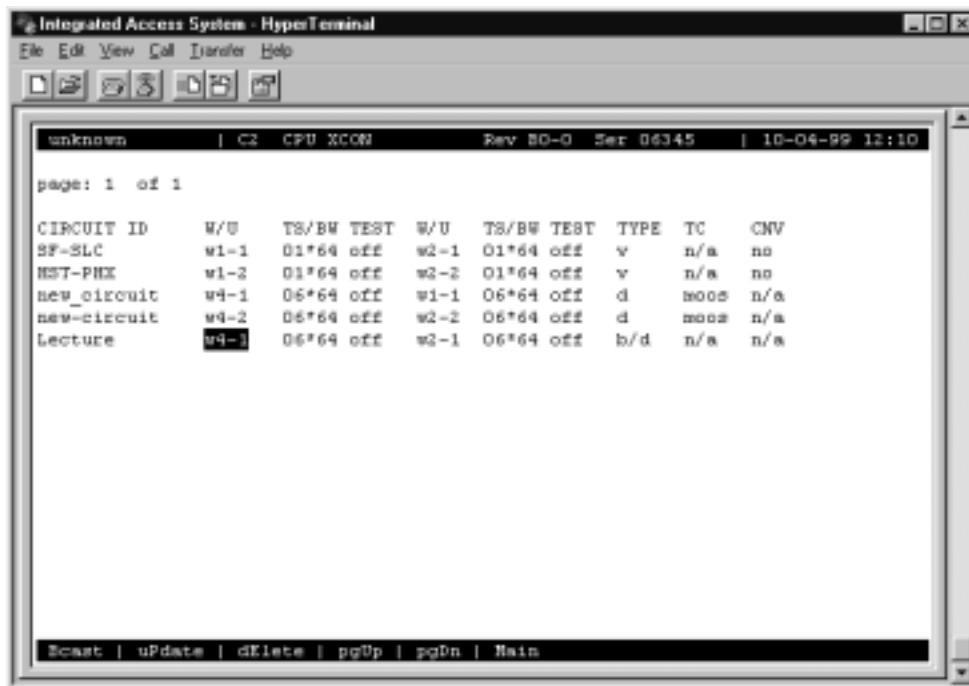

Figure 5-71. Typical Complete Broadcast Circuit

```

Integrated Access System - HyperTerminal
File Edit View Call Transfer Help

unknown | C2 CPU XCON Rev B0-0 Ser 06345 | 10-04-99 12:17

page: 1 of 1

CIRCUIT ID   W/U   TS/BW TEST   W/U   TS/BW TEST   TYPE   TC   CNV
SF-SLC       w1-1  01*64 off    w2-1  01*64 off    v       n/a  no
HST-PHX      w1-2  01*64 off    w2-2  01*64 off    v       n/a  no
new_circuit  w4-1  06*64 off    w1-1  06*64 off    d       noos n/a
new_circuit  w4-2  06*64 off    w2-2  06*64 off    d       noos n/a
Lecture      w4-1  06*64 off    w2-1  06*64 off    b/d     n/a  n/a
Lecture      w4-1  06*64 off    w1-2  06*64 off    b/d     n/a  n/a
Lecture      w4-1  06*64 off    w2-2  06*64 off    b/d     n/a  n/a

Broadcast | uPdate | dElete | pgUp | pgDn | Main

```

Figure 5-72. Three Broadcast Circuits

```

Integrated Access System - HyperTerminal
File Edit View Call Transfer Help

unknown | C2 CPU XCON Rev B0-0 Ser 06345 | 10-04-99 12:19

page: 1 of 1

CIRCUIT ID   W/U   TS/BW TEST   W/U   TS/BW TEST   TYPE   TC   CNV
SF-SLC       w1-1  01*64 off    w2-1  01*64 off    v       n/a  no
HST-PHX      w1-2  01*64 off    w2-2  01*64 off    v       n/a  no
new_circuit  w4-1  06*64 off    w1-1  06*64 off    d       noos n/a
new_circuit  w4-2  06*64 off    w2-2  06*64 off    d       noos n/a
Lecture      w4-1  06*64 off    w2-1  06*64 off    b/d     n/a  n/a
Lecture      w4-1  06*64 off    w1-2  06*64 off    b/d     n/a  n/a
Lecture      w4-1  06*64 off    w2-2  06*64 off    b/d     n/a  n/a

Delete Selected Circuit (y/n)?

Broadcast | uPdate | dElete | pgUp | pgDn | Main

```

Figure 5-73. Typical Deleted Broadcast Circuit

5.23.1 WAN Link to WAN Link

Circuits from a WAN link to another WAN link can also be duplicated from the broadcast screen. Use the same procedure to establish multiple connections for WAN-to-WAN circuits.

In Figure 5-69, highlighting the WAN link circuit on slot w1-1 allows you to cross-connect duplicate information to any other WAN link.

5.23.2 Broadcast Screen Actions

Table 5-12 lists the actions you can perform in the Broadcast Screen. These actions appear on the bottom highlighted line of that screen.

Table 5-12. Broadcast Screen Actions

Action	Function
Bcast	Bcast allows users to program additional broadcast cross-connects in the system. If mistakes are made during the add process, pressing the up arrow or down arrow key will terminate this operation.
uPdate	The uPdate action is initiated by pressing the "p" key. With this command, users can change any of the parameters of a broadcast connection. Use the arrow keys to highlight the area to be changed and close the transaction using the "s" (Save) command.
dElete	The dElete action is initiated by pressing the "e" key. Use this command to delete existing broadcast connections. The system will prompt users to delete the circuit, and the "y" key must be pressed to complete the transaction.
pgUp	The pgUp (Page Up) action is initiated by pressing the "u" key. Since the system can handle many different circuits, users may fill the screen allotment for data. New pages will be added automatically to accommodate additional circuits. The page count feature at the top of the screen shows users the current page and the total amount of pages of information. Use this command to scroll up through the pages of cross-connect information.
pgDn	The pgDn (Page Down) action is initiated by pressing the "d" key. This action is similar to the pgUp command. Use this command to scroll down through the pages of cross-connect information.
Main	Pressing "m" (Main) will return users to the cross-connect screen.

5.23.3 Test Access Digroups (TADS)

The Test Access Digroups (TADS) is a remote test access for data cross connects that pass through the system according to publication TR-TSY-00033, Issue #1, June 1986.

A test center can access the system and assign split intrusive or non-intrusive monitor testing circuits between the unit and the test center via another WAN link. For the purpose of this discussion on Test Access Digroups, the figures show a 64kbps data circuit between Fremont, CA. and Jacksonville, FL. Figure 5-74 shows the cross-connect screen with the data circuits connected.

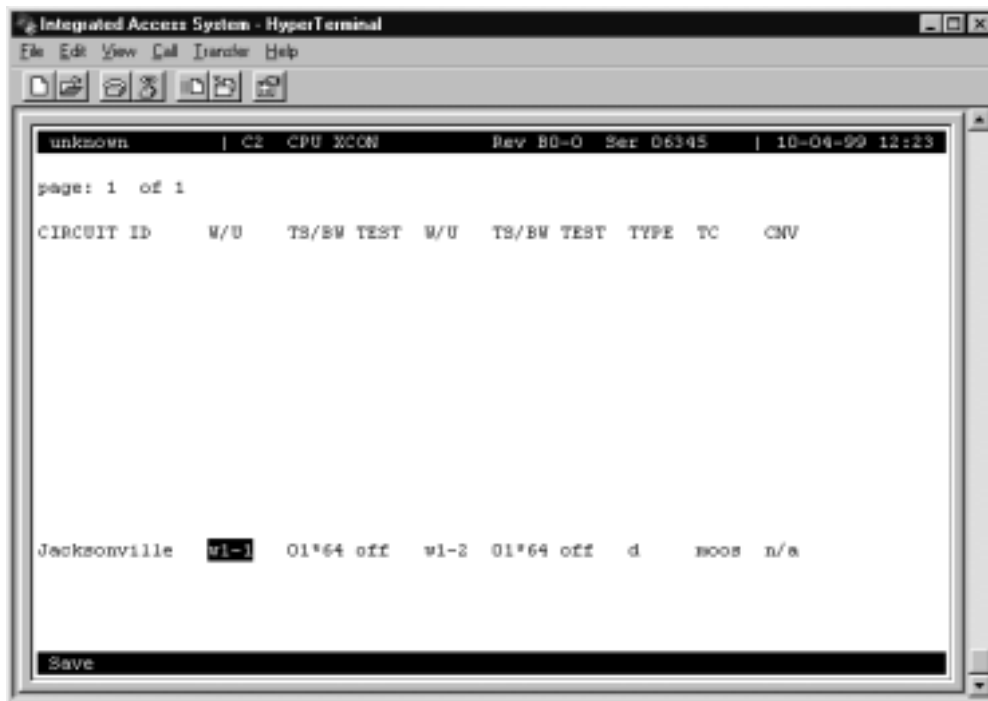

Figure 5-74.The TADS screen

In Figure 5-74, the data circuit called “Jacksonville” is connected on a single time slot between WAN1-1 and WAN1-2.

5.23.4 Monitor Circuit

With the monitor circuit, the data test center (by remote access) creates a “hitless” monitor connection (i.e., one that can be created, maintained and dropped without affecting the information on the circuit being tested) between the data test center and the Node_1 Device.

Highlighting the desired circuit and pressing the “N” key brings up the add monitor circuit screen shown in Figure 5-75.

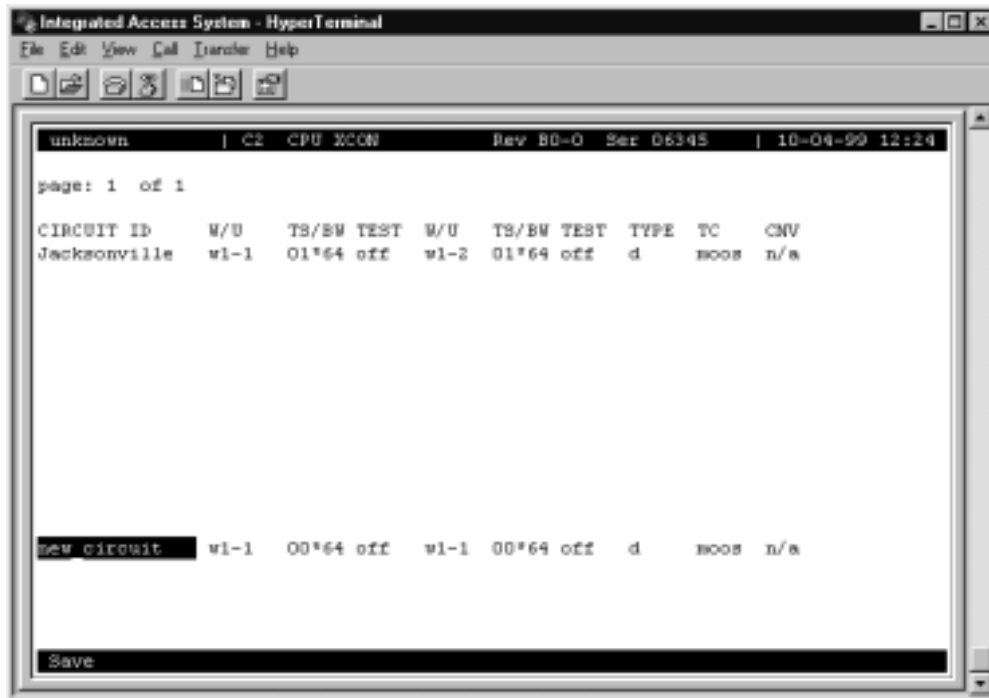
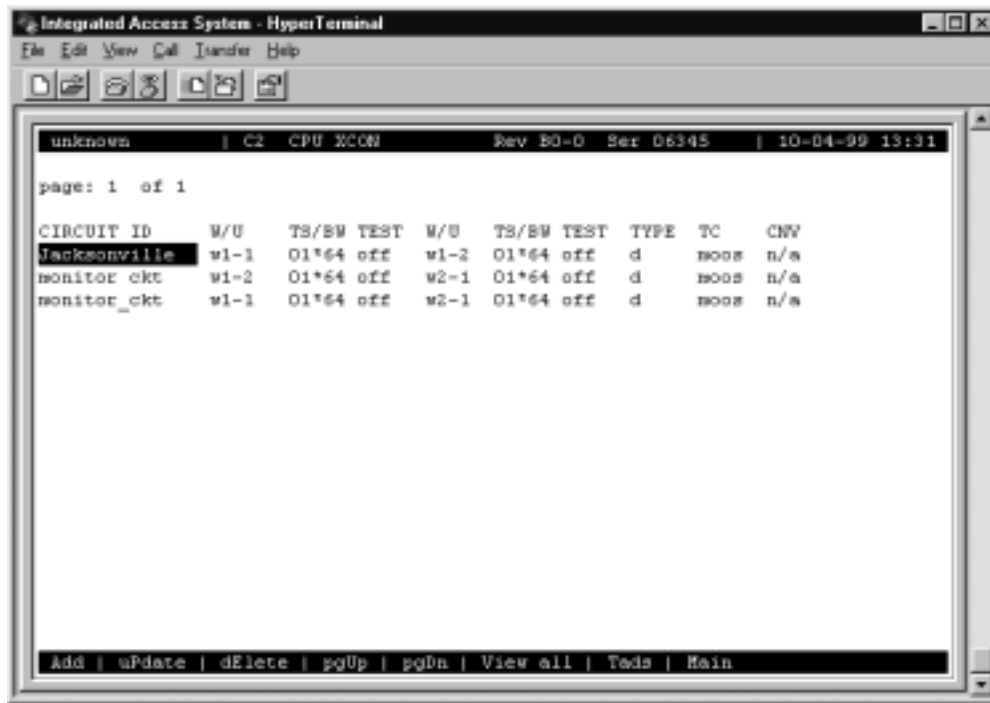

Figure 5-75. The Add Monitor Circuit Screen

Cross connect information is added in a similar fashion to the Add Broadcast screen mentioned previously. Figure 5-76 shows the completed monitor circuit.



The screenshot shows a HyperTerminal window titled "Integrated Access System - HyperTerminal". The window displays a configuration screen for a monitor circuit. The status bar at the top indicates "unknown | C2 CPU ECON Rev B0-0 Ser D6345 | 10-04-99 13:31". The main display area shows a table of circuit configurations. The table has columns for CIRCUIT ID, W/U, TS/SW TEST, W/U, TS/SW TEST, TYPE, TC, and CNV. The first row is highlighted in black and contains the text "Jacksonville". The second and third rows are labeled "monitor_ckt". The bottom status bar contains the text "Add | uPdate | dElete | pgUp | pgDn | View all | Teds | Main".

CIRCUIT ID	W/U	TS/SW TEST	W/U	TS/SW TEST	TYPE	TC	CNV
Jacksonville	w1-1	01*64 off	w1-2	01*64 off	d	noos	n/a
monitor_ckt	w1-2	01*64 off	w2-1	01*64 off	d	noos	n/a
monitor_ckt	w1-1	01*64 off	w2-1	01*64 off	d	noos	n/a

Figure 5-76. Completed Monitor Circuit

Figure 5-77 shows a diagram of how the Monitor circuit splits the original cross connect circuit for testing.

Notice how the test circuit uses two 64kbps WAN time slots, one for the transmit side and one for the receive side of the line.

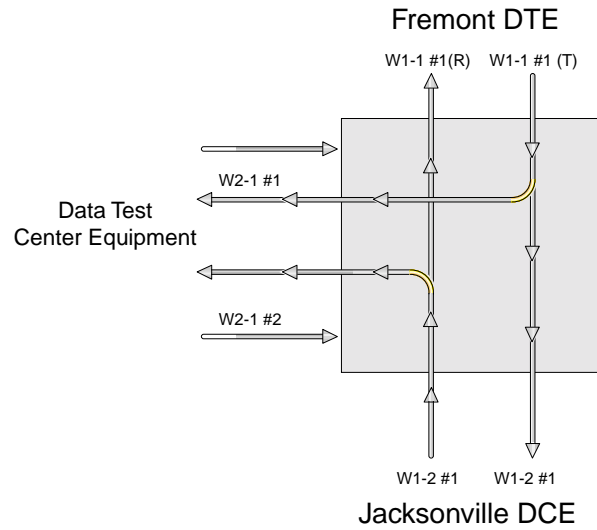



Figure 5-77. Monitor Circuit Diagram

5.23.5 Split Circuit

Pressing the “L” command from the Menu of Actions allows you to split the circuit through the data test center equipment. New circuit information is added in the same way as with the monitor circuit.

With the Split Circuit, the data test center splits the circuit and connects it to their equipment. Unlike the Monitor test circuit, the Split test circuit is intrusive and all transmit and receive data must pass through the equipment at the data test center.

Figure 5-78 shows the TADS screen with a split circuit completed. It uses two 64kbps time slots (like the Monitor circuit). Figure 5-79 shows a diagram of the split test circuit.



The screenshot shows a HyperTerminal window titled "Integrated Access System - HyperTerminal". The window displays a TADS screen with a menu bar (File, Edit, View, Call, Transfer, Help) and a toolbar. The main display area shows the following information:

```
unknown | C2 CPU XCON Rev BD-0 Ser 06345 | 10-04-99 13:41
page: 1 of 1
CIRCUIT ID FACILITY TEST EQUIPMENT TEST TYPE TC CMV
Jacksonville w1-2 01*64 spl w1-2 01*64 spl d moos n/a
split ckt w1-1 01*64 off w1-2 01*64 off s/d moos n/a
split ckt w1-2 01*64 off w2-1 01*64 off s/d moos n/a
```

At the bottom of the screen, there is a navigation bar with the following options: moNitor | spLit | Release | Tla | pgUp | pgDn | Main.

Figure 5-78. TADS Screen with Split Circuits

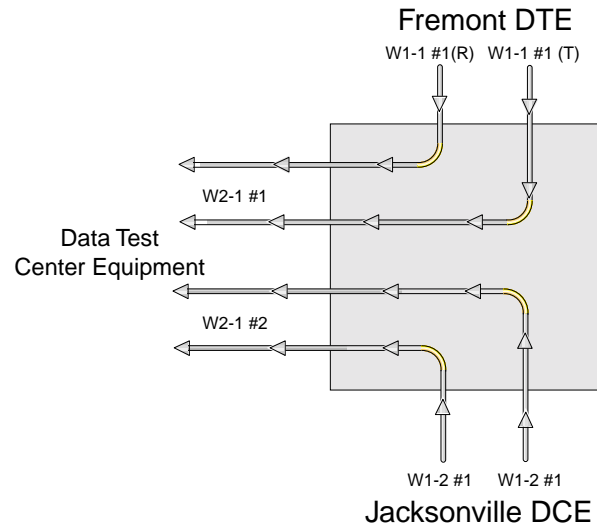

Figure 5-79.Split Circuit Diagram

5.23.6 Release

Pressing the “**R**” (**Release**) command allows you to release the circuit from the data test equipment. The system will verify the action desired with a yes/no question.

With the Release Circuit, the Data Test Center removes the connection between the circuit being tested and restores the circuit to its pre-accessed state.

Figure 5-80 shows the TADS screen with the release verification.

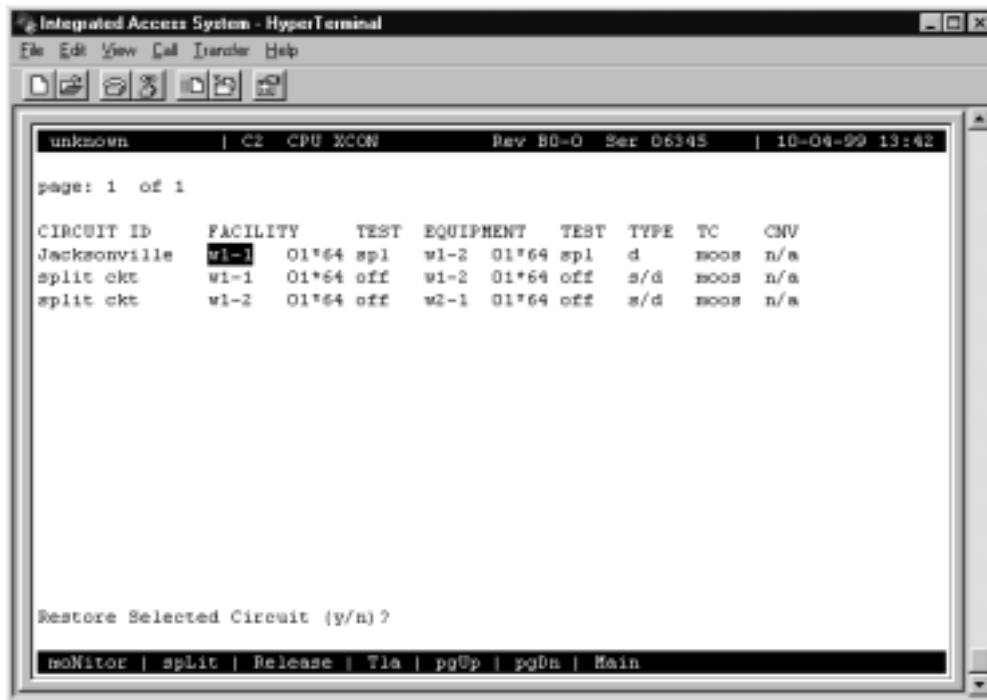

```
Integrated Access System - HyperTerminal
File Edit View Call Transfer Help
[Icons]
unknown | C2 CPU XCON Rev B0-0 Ser 06345 | 10-04-99 13:42
page: 1 of 1
CIRCUIT ID FACILITY TEST EQUIPMENT TEST TYPE TC CNV
Jacksonville w1-1 01*64 spl w1-2 01*64 spl d 8008 n/a
split ckt w1-1 01*64 off w1-2 01*64 off s/d 8008 n/a
split ckt w1-2 01*64 off w2-1 01*64 off s/d 8008 n/a
Restore Selected Circuit (y/n)?
moNitor | spLit | Release | T1a | pgUp | pgDn | Main
```

Figure 5-80.TADS Restore Circuit Screen

5.23.7 Terminate and Leave Access

The Terminate and Leave Access (TLA) circuit gives the data test center the capability to terminate one or both directions of transmission on a circuit by inserting an unassigned channel code (01111111) in the outgoing transmission path(s). The TLA feature is useful in circuit provisioning to turn circuits up and down remotely, and in testing multipoint circuits to isolate and remove noisy bridge legs from service.

Figure 5-81 shows the TLA screen with the choice of Monitor (**mon**) or Unassigned Channel Code (**uca**) to be applied to the highlighted circuit. (If TLA had been applied to a Split circuit, the choices would have been **spl** or **uca**.)

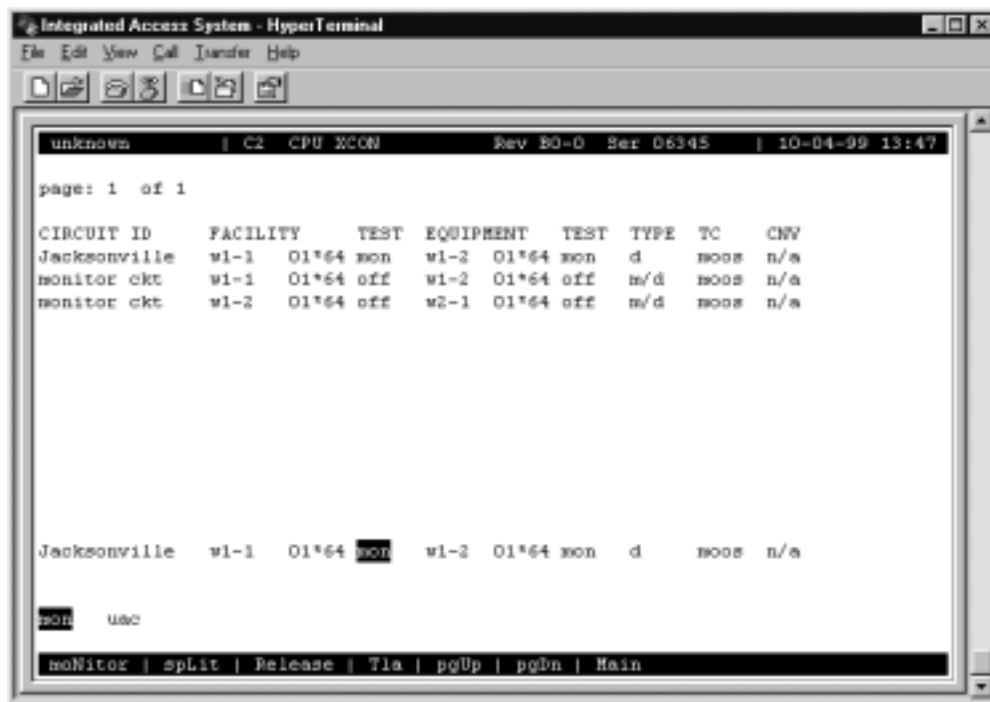

Figure 5-81. TLA Circuit State Screen

Table 5-13. TLA Circuit State Screen Menu of Actions

Action	Function
moNitor	The Monitor command allows the user to create a monitor circuit at the WAN interface. See section above.
spLit	The Monitor command allows the user to create a split circuit at the WAN interface. See section above.
Release	The Release command allows the user to release and restore a split circuit or a monitor circuit. See section above.
Tla	The Terminate and Leave Access (TLA) command is the capability to terminate one or both directions of transmission on a circuit. See section above.

pgUp	The pgUp (Page Up) action is initiated by pressing the "u" key. Since the system can handle many different TADS circuits, you may fill the screen allotment for data. New pages will be added automatically to accommodate additional circuits. Use this command to scroll up through the pages of TADS information.
pgDn	The pgDn (Page Down) action is initiated by pressing the "d" key. This action is similar to the pgUp command. Use this command to scroll down through the pages of cross-connect information.
Main	Pressing "m" (Main) will return you to the cross-connect screen.

5.24 Checking the Time Slot Map

Once you select and assign the time slots, you can view the list of DS0 connections (the time slot map) through the WAN card Cross-Connect Screen for cross-connect systems. You can see the results of your assignments in the time slot map as follows:

1. From the Main Screen, select the WAN card in slot W-1.
2. Type “x” (**Xcon**) to bring up the time slot screen (see Figure 5-82 for T1 operation and Figure 5-83 for E1 operation).
3. Selecting “m” (**Main**) to return users to the WAN card Main Screen.
4. Selecting “m” (**Main**) again will return users to the Main System Screen.

TS	XCON	TS	CIRCUIT_ID	TS	XCON	TS	CIRCUIT_ID
0	frame align		64k	16	cas		64k
1	u2-1	D-03	user_circuit	17	u3-4	A-04	user_circuit
2	u2-1	D-04	user_circuit	18	u3-5	A-05	user_circuit
3	u2-1	D-05	user_circuit	19	u3-6	A-06	user_circuit
4	u2-1	D-00	user_circuit	20	u3-7	A-07	user_circuit
5	u2-1	D-01	user_circuit	21	u3-8	A-08	user_circuit
6	u2-1	D-02	user_circuit	22	u1-1	A-09	user_circuit
7	u2-2	D-09	user_circuit	23	u1-2	A-10	user_circuit
8	u2-2	D-10	user_circuit	24	u1-3	A-11	user_circuit
9	u2-2	D-11	user_circuit	25	u1-4	A-12	user_circuit
10	u2-2	D-06	user_circuit	26	u1-5	A-13	user_circuit
11	u2-2	D-07	user_circuit	27	u1-6	A-14	user_circuit
12	u2-2	D-08	user_circuit	28	u1-7	A-15	user_circuit
13	u3-1	A-01	user_circuit	29	u1-8	A-17	user_circuit
14	u3-2	A-02	user_circuit	30			
15	u3-3	A-03	user_circuit	31			

Refresh | Test | Main

Figure 5-82. Typical Time Slot Screen for T1 Operation

For E1 transmission (Figure 5-83), time slot 0 and 16 are not available for assignment on either the HSU table or the voice card time slots. Like T1 operation in d/i mode, unspecified time slots are **automatically** assigned to corresponding slots on the other WAN port on the same card.

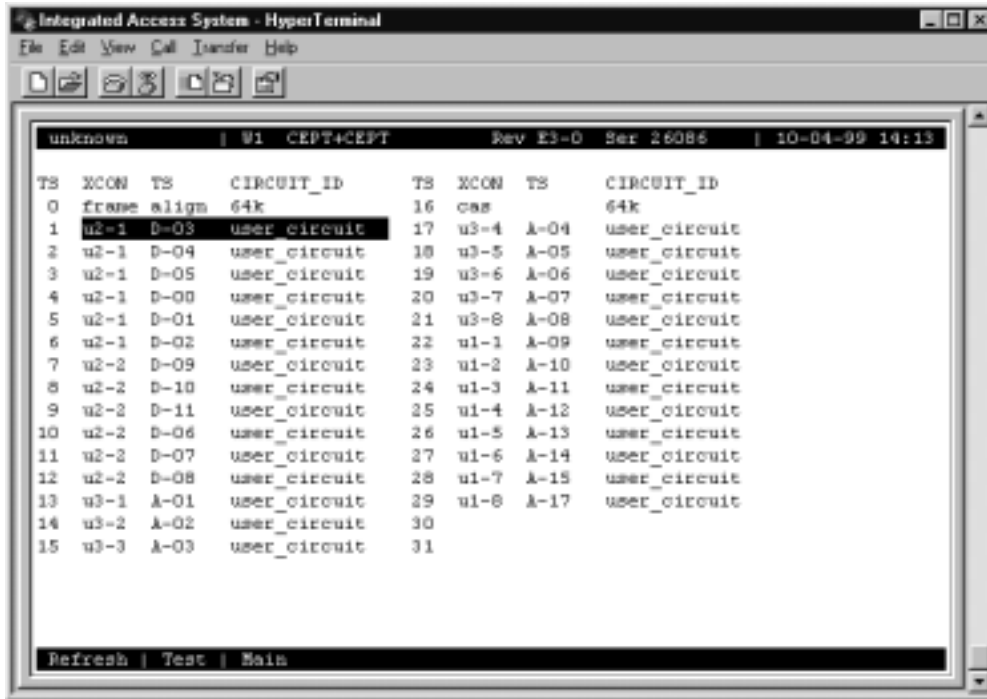

Figure 5-83. Typical Time Slot Screen in E1 Operation

5.25 Recording the Time Slot Configuration

After setting up the initial system configuration and define the time slot map, record this information on paper. Recording the initial configuration in a logical manner will help if you have a problem later.

Record the information in a way that makes sense to you and will be easy for others to understand. Also be sure to note the initial settings for each card in copies of the T1 or E1 operation tables provided in Table 5-14 and Table 5-15. Store all initial configuration information in a safe place where anyone needing to service the system can easily find it.

Table 5-14. Time Slot Recording Form for T1 Operation

WAN Port No. _____ - _____

TS Number	Card Type	Port Number
1		
2		
3		
4		
5		
6		
7		
8		
9		
10		
11		
12		
13		
14		
15		
16		
17		
18		
19		
20		
21		
22		
23		
24		

Recording the Time Slot Configuration System Configuration and Operation

Table 5-15. Time Slot Recording Form for E1 Operation
WAN Port No. _____ - _____

TS Number	Card Type	Port Number
0		
1		
2		
3		
4		
5		
6		
7		
8		
9		
10		
11		
12		
13		
14		
15		
16		
17		
18		
19		
20		
21		
22		
23		
24		
25		
26		
27		
28		
29		
30		
31		

5.26 Redundant Operations

This section describes the redundancy features of the Integrated Access System, and provides instructions for configuring the system with redundant elements.

The Integrated Access System can be configured with redundant (backup) critical system elements. This feature switches operation from failed components to identical backup replacements, thereby reducing the likelihood of service disruptions.

The four areas of redundant operation are the power system, the CPU card, WAN card, and ADPCM cards. These are described below.

5.27 Power Supply Redundancy

Each power supply component is designed to switch to a backup if a primary unit fails. Also, the defective unit will create a system alarm upon failure, to alert an operator so that the necessary diagnostic and repair work can be initiated. The following power supply components can have redundancy:

- AC Power Supply
- DC Power Supply
- AC/DC Converter
- Ringing generator (master only; see below)

Upon failure, the LED on the AC-DC power converter will be turned off but **will not generate a system alarm** (unless the system is equipped with the ALR 4+3PF Card (External Alarm card)).

If the primary ringing generator fails, an alarm will be generated and the LED will turn off. If a backup ringing generator fails, the LED will turn off but no alarm will be generated by the system.

Figure 5-84 shows a System Main Screen with redundant power supplies, in which Power Supply 1 (PS1) has failed. The power supply failure is noted in the alarm message **PS1 OOS** in the upper right corner of the screen.



Figure 5-84. Typical Redundant-Power Supply System Main Screen

5.28 CPU Card Redundancy

CPU card redundancy is valuable because the CPU card is essential to system operation. CPU redundancy is supported using two CPU-7 XCON (880770). The CPU card in slot C2 will be the redundant card for the CPU XCON card in slot C1, but only if they are both the same type with the same level of Host Code, for example 7.0.x. For redundancy, the first two digits of the Host Code must be the same, but the last digit does not matter.

A switch from one CPU card to the other is triggered by any of the following:

- A software command issued by an operator
- Removal of the active CPU card from the system
- Failure or malfunction of the active CPU card

During a CPU redundancy switch over, disruptions to voice and data traffic are momentary and traffic will recover automatically.

Figure 5-85 shows a System Main Screen with redundant CPU cards. The card in slot C1 is active, and the card in slot C2 is redundant. To switch operation to the redundant CPU card, press “w” to invoke the **cpusWtch** command from the bottom highlighted line of this screen. The system prompts you with a yes/no confirmation prompt, as shown.



Figure 5-85. Manually Switching to a Redundant CPU

At the prompt, press “y”. The CPU card in slot C2 is now active, and the CPU card in C1 is redundant (**RDNT** status), as shown in Figure 5-86. These states remain in effect on both cards until you manually switch back to the CPU card in slot C1.



Figure 5-86. Typical System with CPU Switchover Completed

When configuring a system with 880770 CPU w/Ethernet card, you must use two 880770 cards and cable both to the LAN to keep the Ethernet port functioning after a CPU switch.

5.29 WAN Card Redundancy

Both T1 and E1 WAN redundancy are supported in cross-connect systems.

The cross-connect system allows 1:N redundancy with an 801460 or 801470 WAN in slot W4 protecting the 801060 or 801070 WANs in slot W1 through W3. Only WAN cards with identical DSX, CEPT and/or CSU modules and configured the same are protected. The 801460 and 801470 1:N redundancy protects against WAN card failure only, it does not protect against T1/E1 facility failure. The 801460 and 801470 WAN card in slot W4 must not have any T1/E1 connections as it will disturb the signal and cause a constant CGA alarm to be logged.

WAN redundancy switching can be initiated by one of the following:

- A software command issued by the operator
- Removal of the active WAN card from the system
- Failure of the active WAN port or card
- CGA alarm declaration on the active WAN port or card

During a WAN redundancy switch, voice and data traffic are momentarily disrupted, and transmission then recovers automatically.

5.29.1 Cross-Connect WAN Card Redundancy Switching

In cross-connect systems, WAN redundancy requires a WAN-R DUAL card in slot W4 (as marked on its faceplate ejector). This card becomes a redundant card for the WAN cards in slots W1 through W3 if it is equipped with matching DSX/CEPT, CSU, or HDSL modules, and if those modules are installed in the same positions on both WAN cards. This protection scheme is known as 1-in-N redundancy. When a switch occurs, a relay on the WAN-R card switches the output of that card to the corresponding pins on the WAN connector of the Interface card.

The following restrictions apply to cross-connect WAN redundancy:

You must install the WAN-R card in slot W4 for redundancy. If you install it in slot W1, W2 or W3, it will work only as a standard WAN card with two ports.

For the 801x60 WAN series, if the plug-in modules on the WAN-R card do not match those on a card in slot W1, W2, or W3, the WAN-R card will not behave as a backup for that active WAN card. For the 801x70 WAN series, the strapping of the card must match the WAN card that is being protected. The system will not reject the card, but it will not switch even if the active WAN card fails. **NOTE:** Use of WAN 801x60 and 801x70 cards in the same shelf is supported, however the 801470 card should be used in the WAN-R slot when mixing cards. The 801x70 cards take longer to initialize than the 801x60 cards. In case the IMACS shelf is restarted, the 801x60 cards will always come up faster than the 801x70 cards.

Therefore if a situation occurs (such as a shelf restart or power cycle), an 801460 card in the RDNT slot will swiftly come into service, and therefore take over traffic for an 801070 which is still booting up. When mixing cards, the 801470 card should be used in the RDNT slot (W4) to prevent undesired protection switches in case of a system re-initialization.

If a standard WAN card is in slot W4, the system does not support WAN redundancy.

In cross-connect systems, switching always occurs on both ports of a WAN card. Therefore, both ports of all active WAN cards must have the same plug-in modules as the redundant-card ports.

Figure 5-87 shows a System Main Screen for a cross-connect system with WAN card redundancy. In this example, the CSU ports of the WAN cards in slots W1, W2, and W3 are backed up by the CSU ports of the WAN card in slot W4. The redundant WAN card in slot W4 takes over for the first active WAN card that fails.

unknown | 10-04-99 14:47

Slot	Installed	Status
C1	CPU XCON	RDNT
C2	CPU XCON	****
P1/U1	Ech 4Wx8ER	*****
P2/U2	MSU-530x4	****
P3/U3	FXO 2Wx8-6	*****
U4/U4	BRI-Ux8ec	***** *
W1/U5	DSX+DSX	ss
W2/U6	DSX+DSX	ss
W3/U7	DSX+DSX	ss
W4/U6	DSX+DSX	ss
IF	INTF+modem	
S1	PS1	
S2		
RI		

Alarms | Config | Del | accept | Xcon | sYs | Logout | sEr | Oos | cpusWtch

Figure 5-87. Typical Cross-Connect System with WAN Card Redundancy

Figure 5-88 shows a WAN Card Main Screen for the card in slot W1 with port 1-1 selected. To force a switch, press “w” (sWitch command), then press “y” to complete the switch. The traffic on the WAN card in slot W1 will be switched to the WAN-R card in slot W4. The Main System Screen (see Figure 5-889) now shows both ports of the card in slot W4 as active port (Status = **aa**) and the ports on the card in slot W1 as redundant (Status = **rr**).

```

Integrated Access System - HyperTerminal
File Edit View Call Transfer Help

unknown | W1/05 DSX+bSX Rev E3-0 Ser 25481 | 10-04-99 14:50

          DSX                bSX
STATE      stdby             STATE      stdby
MODE       xcon             MODE       xcon
FORMAT     esf              FORMAT     esf
LINE CODE  b8zs             LINE CODE  b8zs
PULSE      n/a             PULSE      n/a
LINE LEN   133             LINE LEN   133
SLIP LIM   126             SLIP LIM   126
AIS/ALM    none            AIS/ALM    none
LINE LB    off             LINE LB    off
LOCAL LB   off             LOCAL LB   off
CH LB      off             CH LB      off
LB ADDR    01             LB ADDR    01
LB GEN     off             LB GEN     off
LB DET     w/to           LB DET     w/to
ESF/NMS BP atct           ESF/NMS BP atct
EER THRD   10e-4          EER THRD   10e-4
BINT RULES 008            BINT RULES 008
GROUP      none           GROUP      none
OK to switch to the redundant WAN [y/n] ?

Save | Undo | Refresh | Xcon | Perf | Farstat | Test | sWitch | plrs | Main

```

Figure 5-88. Switching to a Redundant Cross-Connect WAN Card



Figure 5-89. Typical Cross-Connect WAN Card Redundancy Switch in Progress

5.30 ADPCM Card Redundancy

The Integrated Access System can also have ADPCM cards, which use voice compression technology to effectively increase the digital voice transmission capabilities of voice cards (E&M, FXS, or FXO) or WAN links. See Server Card Reference Guide for more information on the ADPCM card.

Each system can have up to three ADPCM cards in slots P1 through P3, depending on slot availability. In systems with two or three ADPCM cards, any of those cards can be selected as the redundant (backup) card. There are no restrictions on chassis slot order.

Figure 5-90 shows a system with three ADPCM cards. The ADPCM card in slot P1 is highlighted. Pressing <Enter> will bring up the ADPCM Main Screen shown in Figure 5-9111.

Slot	Installed	Status
C1	CPU XCON	BINT
C2	CPU XCON	****
P1/U1	ADPCM-64x1	*****
P2/U2	ADPCM-64x1	*****
P3/U3	ADPCM-64x1	*****
U4/U4	BRI-Ux8ac	***** *
M1/U5	E4M 49x8ER	*****
M2/U6	HSU-530x4	****
M3/U7	DSX+DSX	**
M4/U8	DSX+DSX	**
IF	INTF+modem	
S1	PS1	
S2		
RI		

unknown | 10-04-99 15:01

Alarms | Config | Del | accepT | Xcon | sYs | Logout | sEr | Oos | cpusWch

Figure 5-90. Typical System with Redundant ADPCM Cards

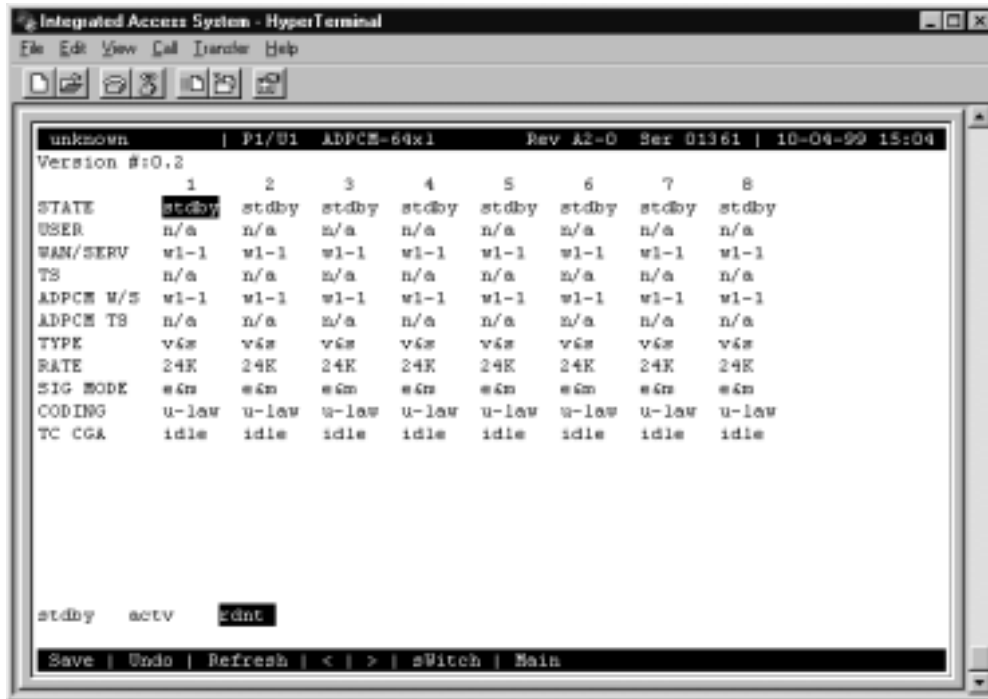

Figure 5-91. Typical ADPCM Card Main Screen

To choose a redundant ADPCM card for the system, proceed as follows:

1. Go to the System Main Screen (if you are not already there).
2. Select the desired ADPCM card from the System Main Screen, and press <Enter> to go to the Main Screen of that card. Figure 5-91 shows the card in slot P1 is chosen.
3. Highlight the STATE parameter of any ADPCM port on the card, and press the <Enter> key. This changes the STATE setting to **rdnt**. The entire ADPCM card now becomes the redundant ADPCM card for the system.

The System Main Screen now looks like Figure 5-922. The status of all ADPCM ports of the card in slot P1 is “r”.

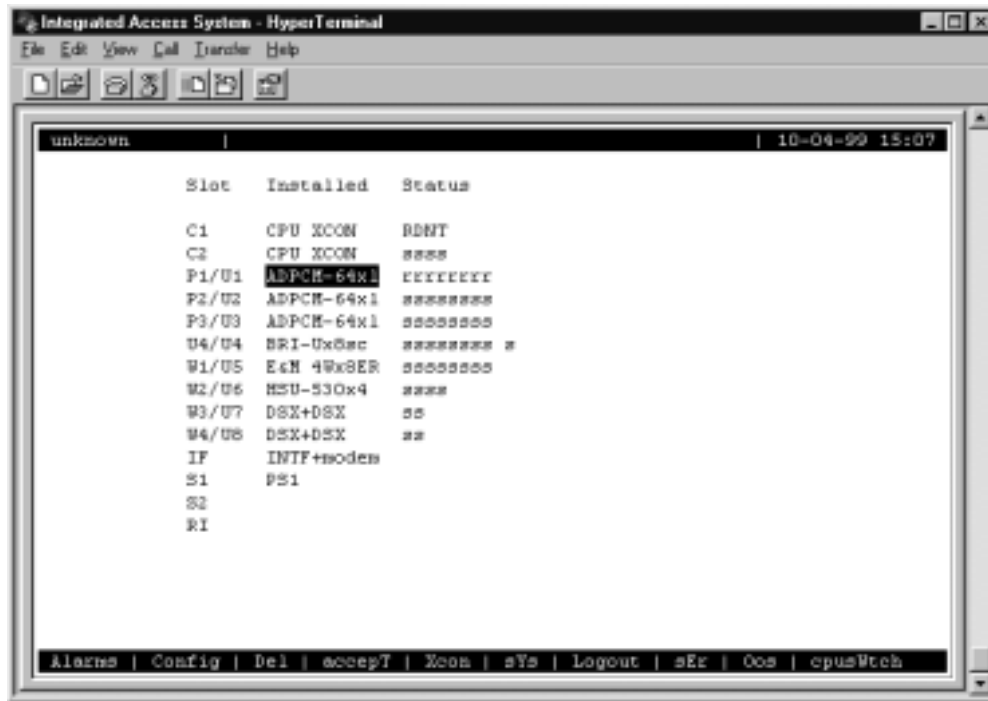

Figure 5-92. Typical ADPCM Card Redundancy Switch in Progress

If the card in slot P2 or P3 fails, the entire voice compression network will switch to the redundant card in slot P1. When the Out of Service condition is repaired, the ADPCM card in the slot that previously failed becomes the redundant card for the system.

The system does not require any ADPCM cards to be redundant. All three slots (P1 to P3) can be used for normal traffic on ADPCM voice networks.

Chapter 6

System Testing and Diagnostics

6.1 Introduction

This chapter describes the Integrated Access Systems' comprehensive set of built-in diagnostic tools that enable the operator to remotely troubleshoot and resolve problems. Throughout the user card chapters in this system reference guide are brief explanations of system testing and problem solving. However this chapter was designed to provide a "full picture" of what this Integrated Access System is capable of providing.

6.2 Integral Test Capabilities

The Integrated Access System provides diagnostics capabilities to resolve problems. There are system-generated alarm messages described in *Chapter 4. System Configuration and Operation*, the integral diagnostics capabilities of this system include Bit Error Rate Testers (BERTs) on data cards, tone generators on analog voice cards, the ability to manipulate the analog leads and the digital signaling bits of voice circuits and extensive loopback generation and detection capability on many system elements.

The ability to initiate loopbacks at various points in a circuit, coupled with the ability to generate and receive test signals and to collect performance and error information, enable the operator to systematically troubleshoot circuit problems. It allows the operator to determine if the problem resides in the system, and whether the problem can be isolated down to a specific Field Replaceable Unit (FRU) within the system. Since all of these diagnostic tools can be operated from a remote VT100 terminal, troubleshooting begins immediately without dispatching an on-site technician.

6.3 User Card Diagnostics

6.3.1 WAN Diagnostics

Software-initiated diagnostics on T1 and E1 WAN aggregates include looping the WAN signal toward the network (line loopback) or the system (local loopback) and placing any one of the DS0 channels that make up the WAN signal in local loopback. The table below list detailed information on the diagnostic capabilities of the WAN cards.

Loopbacks	T1/CSU	T1/DSX	E1/CEPT/HDSL
On-Card loopbacks			
T1/E1 Line loopback Toward Network	Yes	Yes	Yes
T1/E1 Local loopback Toward User	Yes	Yes	Yes
DS0 Channel loopback Toward Network	No	No	No
DS0 Channel loopback Toward User	Yes	Yes	Yes
In-Band loopback Code Generation			
Industry-Standard T1/E1 Loop-Up Code	Yes	Yes	N/A
Industry-Standard T1/E1 Loop-Down Code	Yes	Yes	N/A
In-Band loopback Code Detection			
Industry-Standard T1/E1 Loop-Up Code	Yes	Yes	N/A
Industry-Standard T1/E1 Loop-Down Code	Yes	Yes	N/A
Bit Error Rate Tester (BERT)			
Patterns Supported			
All 1s	Yes	Yes	Yes
All 0s	Yes	Yes	Yes
1:1	Yes	Yes	Yes
1:7	Yes	Yes	Yes
511	No	No	No
2047	No	No	No
3:24	Yes	Yes	Yes
QRSS	Yes	Yes	Yes
BERT Direction			
Toward User	No	No	No
Toward Network	Yes	Yes	Yes
Statistics Gathered by BERT			
Bit Errors (BE)	Yes	Yes	Yes
Errored Seconds (ES)	Yes	Yes	Yes
Severely Errored Seconds (SES)	Yes	Yes	Yes
Consecutive Severely Errored Seconds	Yes	Yes	Yes
Out of Synchronization Seconds (OOS)	Yes	Yes	Yes
Bit Error Rate (BER)	Yes	Yes	Yes
Elapsed Seconds (ELAP)	Yes	Yes	Yes
HDSL Errored Seconds	N/A	N/A	Yes*
HDSL Severely Errored Seconds	N/A	N/A	Yes*
HDSL Unavailable Seconds	N/A	N/A	Yes*



Note: *Applicable only for the E1-HDSL plug-in module. Also the same statistics are available for the remote end.

6.3.2 Voice Diagnostics

The software-initiated diagnostics supported are voice cards include the setting of both analog and digital loopbacks toward the network and the generation of Quiet Tone and a Digital MilliWatt signal on a port-by-port basis. The operator can also monitor and set the state of the analog leads of any FXS, FXO or E&M port. They can set and monitor the state of the ABCD signaling bits of the digitized voice signal. In cross-connect system, test functionality also includes the ability to generate test tones (300Hz, 1 kHz and 3 kHz) and transmit those toward the user side or the network side of the system. The table below shows detailed information on the diagnostic capabilities of the Voice cards.

	2-wire E&M	4-wire E&M	4-wire Extended E&M	2-wire FXS	2-wire FXO
On-Card loopbacks					
Analog Toward Network	Yes	Yes	Yes	Yes	Yes
Digital Toward Network	Yes	Yes	Yes	Yes	Yes
Signaling Manipulation					
Set Status of Analog Interface Leads	Yes	Yes	Yes	Yes	Yes
Set Transmit ABCD Signaling Bits	Yes	Yes	Yes	Yes	Yes
Set Receive ABCD Signaling Bits	Yes*	Yes*	Yes*	Yes*	Yes*
Monitor Status of Analog Interface Leads	Yes	Yes	Yes	Yes	Yes
Monitor Status of Transmit ABCD Signaling Bits	Yes	Yes	Yes	Yes	Yes
Monitor Status of Receive ABCD Signaling Bits	Yes	Yes	Yes	Yes	Yes
Tone Generation					
Tone Supported					
300 Hz	Yes*	Yes*	Yes*	Yes*	Yes*
1 kHz	Yes*	Yes*	Yes*	Yes*	Yes*
3 kHz	Yes*	Yes*	Yes*	Yes*	Yes*
Quiet Tone	Yes	Yes	Yes	Yes	Yes
Digital MilliWatt	Yes	Yes	Yes	Yes	Yes
Tone Direction					
Toward User	Yes	Yes	Yes	Yes	Yes
Toward Network	Yes	Yes	Yes	Yes	Yes



Note: *This feature is only supported in Cross-Connect Systems.

6.3.3 Data Diagnostics

Data diagnostics support varies among data cards. Generally, data card diagnostics supported include the setting of various levels of loopbacks toward the network or the attached DTE equipment. Other support includes the ability to generate and respond to industry-standard loop-up and loop-down codes that are compatible with DDS, V.54 and/or Fractional T1 (FT1) formats. The DS0-DP data card generates and detects DS0-DP loopback codes. The table below shows detailed information on the diagnostic capabilities of the Data cards.

	EIA530 HSU 2-port	V.35 HSU 2-port	EIA530/V.35 HSU 4-port	SRU	OCU-DP 2/5/10-port	DS0-DP 4-port
Loopbacks						
On-Card loopbacks						
Toward DTE	Yes	Yes	Yes	Yes	Yes	Yes
Toward Network	Yes	Yes	Yes	Yes	Yes	Yes
In-Band loopback Code Generation						
Latching DDS-OCU	Yes	Yes	Yes	Yes	Yes	Yes
Latching DDS-DSU	Yes	Yes	Yes	Yes	No	Yes
Latching DDS-CSU	Yes	Yes	Yes	Yes	Yes	Yes
Latching DDS-DS0	Yes	Yes	Yes	No	Yes	Yes
ITU (CCITT) V.54	Yes	Yes	Yes	No	No	No
ANSI Fractional T1 (FT1)	Yes	Yes	Yes	No	No	No
Control Lead Handling						
Set CTS	Yes	Yes	Yes	Yes	N/A	N/A
Set RLSD	Yes	Yes	Yes	Yes	N/A	N/A
Set DSR	Yes	Yes	Yes	No	N/A	N/A
Monitor RTS	Yes	Yes	Yes	Yes	N/A	N/A
Monitor DTR	Yes	Yes	Yes	No	N/A	N/A

	EIA530 HSU 2-port	V.35 HSU 2-port	EIA530/V.35 HSU 4-port	SRU	OCU-DP 2/5/10-port	DS0-DP 4-port
Bit Error Rate Tester (BERT)						
Patterns Supported						
All 1s	Yes	Yes	Yes	Yes	Yes	No
All 0s	Yes	Yes	Yes	Yes	Yes	No
1:1	Yes	Yes	Yes	Yes	Yes	No
1:7	Yes	Yes	Yes	Yes	Yes	No
511	Yes	Yes	Yes	Yes	Yes	No
2047	Yes	Yes	Yes	Yes	Yes	No
QRSS	Yes	Yes	Yes	No	Yes	No
BERT Direction						
Toward User	No	No	No	No	Yes	No
Toward Network	Yes	Yes	Yes	No	Yes	No
Statistics Gathered by BERT						
Bit Errors (BE)	Yes	Yes	Yes	Yes	Yes	No
Errored Seconds (ES)	Yes	Yes	Yes	Yes	Yes	No
Severely Errored Seconds (SES)	Yes	Yes	Yes	Yes	Yes	No
Consecutive Severely Errored Seconds	Yes	Yes	Yes	Yes	Yes	No
Out of Synchronization Seconds (OOS)	Yes	Yes	Yes	Yes	Yes	No
Bit Error Rate (BER)	Yes	Yes	Yes	Yes	Yes	No
Elapsed Seconds (ELAP)	Yes	Yes	Yes	Yes	Yes	No

6.4 System with Cross-Connect Option

6.4.1 Circuit Diagnostics

In systems equipped with Cross-Connect CPUs, the cross-connect element adds another level of testing within the node and enhances the system's diagnostic capabilities. The operator may also monitor and set the state of the Transmit and Receive ABCD signaling bits of a digitized voice circuit that is cross-connected between WANs. The table below shows detailed information on the diagnostic capabilities of the circuits.

	Voice without Signaling	Voice with Signaling	Single Data DS0 (64 Kbps)	Super-rate Data (N x 64 Kbps)
Loopbacks				
Local loopbacks				
Toward WAN1	Yes	Yes	Yes	Yes
Toward WAN2	Yes	Yes	Yes	Yes
Bit Error Rate Tester (BERT)				
Patterns Supported				
All 1s	Yes	Yes	Yes	Yes
All 0s	Yes	Yes	Yes	Yes
1:1	Yes	Yes	Yes	Yes
1:7	Yes	Yes	Yes	Yes
M_OOS	Yes	Yes	Yes	Yes
BERT Direction				
Toward WAN1	Yes	Yes	Yes	Yes
Toward WAN2	Yes	Yes	Yes	Yes
Tones Supported				
300 Hz	Yes	Yes	Yes	Yes
1 kHz	Yes	Yes	Yes	Yes
3 kHz	Yes	Yes	Yes	Yes
Tone Direction				
Toward WAN1	Yes	Yes	Yes	Yes
Toward WAN2	Yes	Yes	Yes	Yes

	Voice without Signaling	Voice with Signaling	Single Data DS0 (64 Kbps)	Super-rate Data (N x 64 Kbps)
Signaling Manipulation				
Toward WAN 1				
Set Transmit ABCD Signaling Bits	N/A	Yes	N/A	N/A
Monitor Status of Transmit ABCD Signaling Bits	N/A	Yes	N/A	N/A
Monitor Status of Receive ABCD Signaling Bits	N/A	Yes	N/A	N/A
Toward WAN 2				
Set Transmit ABCD Signaling Bits	N/A	Yes	N/A	N/A
Monitor Status of Transmit ABCD Signaling Bits	N/A	Yes	N/A	N/A
Monitor Status of Receive ABCD Signaling Bits	N/A	Yes	N/A	N/A

6.5 Benefits of Built-In Diagnostics

The real power of the integral diagnostics of the Integrated Access System can be fully appreciated when the individual diagnostic tools are applied to everyday troubleshooting such as the one illustrated in the following example.

The environment shown in Figure 6-1 consists of two integrated access devices connected by a T1 line. These are referred to as the Local IAD and the Remote IAD respectively. At the local IAD, the DTE equipment is a co-located device providing a 56 Kbps V.35 interface that is connected to a V.35 HSU port. At the Remote IAD, an OCU-DP card that interfaces to the 4-wire DDS tail-circuit extends the 56 Kbps to a third location. Consequently, the Remote IAD is equipped with an OCU-DP card that interfaces to the 4-wire DDS tail-circuit. At the third location, the DDS circuit terminates in a generic, third-party DSU/CSU which in turn provides a 56 Kbps V.35 interface to the remote DTE device.

The system operator can use the diagnostic tool kit to systematically troubleshoot the problem on an end-to-end basis and to identify the faulty sub-system, even if it is external to the Integrated Access System. One way to systematically troubleshoot the problem is illustrated in Figure 6-1. While there are many other approaches, in general, the procedure to follow is to combine loopbacks that are generated either through software commands or via industry-standard loop-up codes with Bit Error Rate Tests (BERTs) for data circuits, or test tones for voice circuits. In the Integrated Access System, all of those tools are available as integral features of the system and of the various cards. Each test determines if a specific sub-system is operating properly. In our example, after each test, the sub-systems that are shown to be functioning properly are shaded in gray.

In Figure 6-1, the local HSU card is put in Local loopback and a BERT test is run from the DTE. If successful, in Figure 6-1, diagnostics-3 the loopback sequence is advanced by putting the T1 link of the Local Integrated Access System in Local loopback and running BERT test again. This also tests the cross-connect element of the local Integrated Access System if there is one present.

In Figure 6-1, diagnostics 4, the T1 link of the remote Integrated Access System is configured in Line Loopback. Alternatively, a loop up code can be sent from the local Integrated Access System to put the T1 link of the remote Integrated Access System in Line loopback. This process is repeated until the remote DTE is put in network loopback and tested as shown in Figure 6-2, diagnostics 8.

agnostics 1

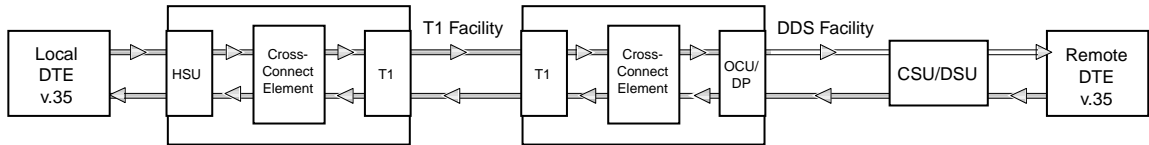

agnostics 2

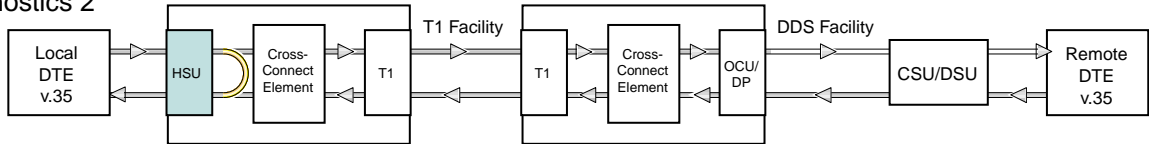

agnostics 3

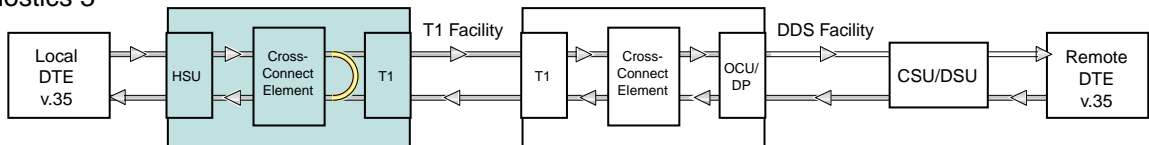

agnostics 4

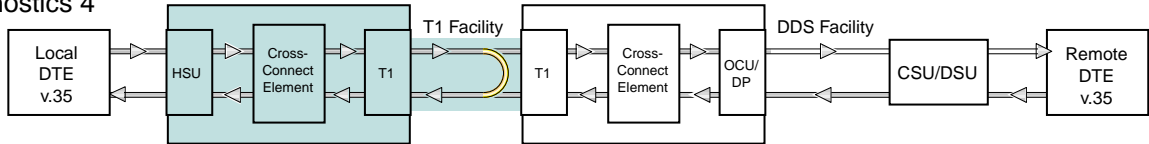

Figure 6-1. Built-In Diagnostics Example (Diagnostics 1 - 4)

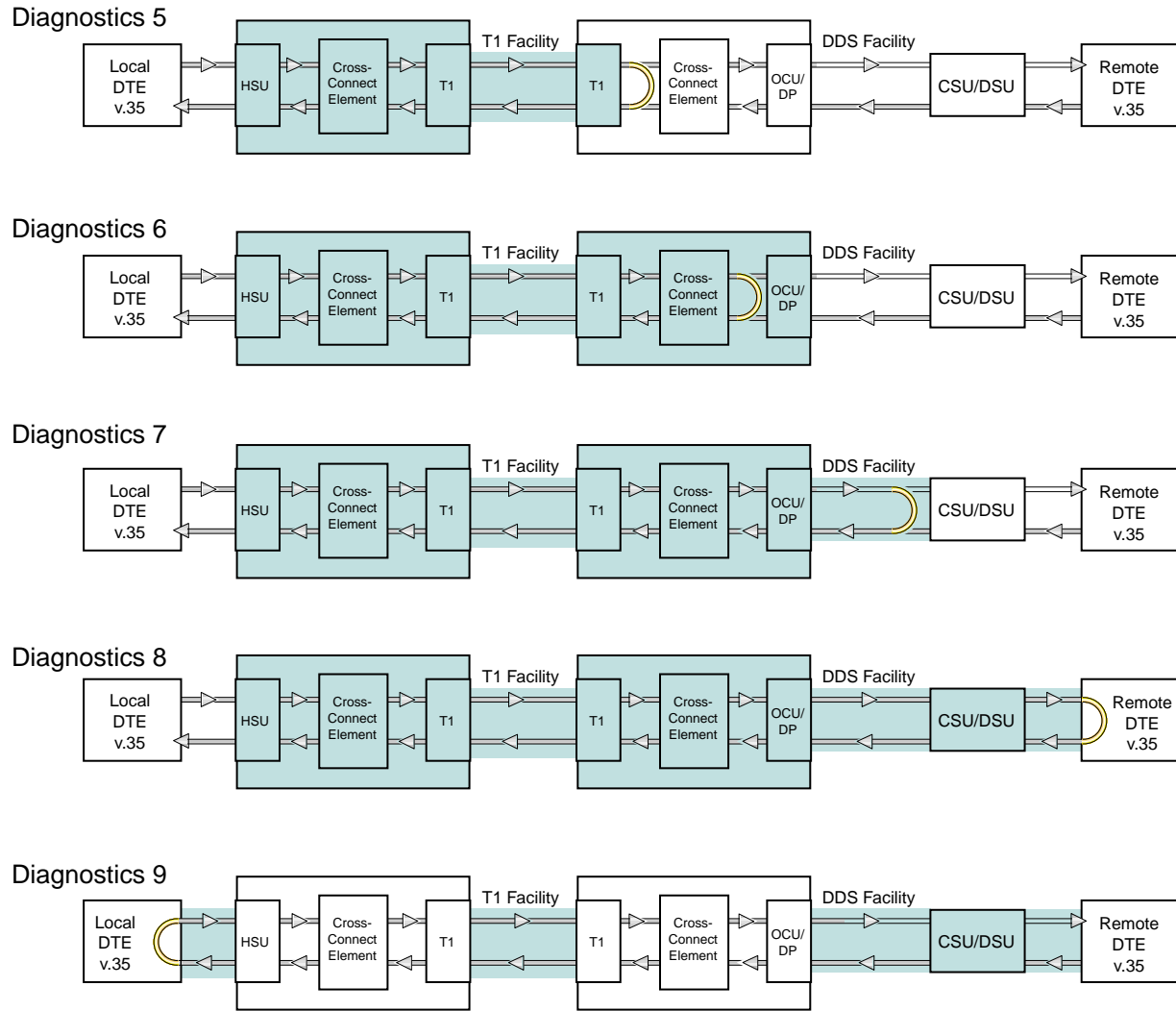

Figure 6-2. Built-In Diagnostics Example (Diagnostics 4 - 8)

6.6 Performance Monitoring

The Integrated Access System provides non-intrusive performance monitoring of T1 lines and DDS circuits that terminate on OCU-DP cards. This capability is built into the system software and does not require any special options or expensive external equipment.

6.6.1 T1 Line Performance Monitoring

Performance monitoring, statistics gathering and performance reporting of T1 facilities is supported in this system. In ESF format, CRC errors, Out-of-Frame errors, and Controlled Slips are combined to provide line quality and performance statistics in accordance with industry standards. In D4 format, Bipolar Violations (BPVs) are used instead of CRC errors. The performance statistics are gathered and displayed in fifteen-minute intervals for the preceding twenty-four hours. They include Errored Seconds, Unavailable Seconds, Severely Errored Seconds, Bursty Errored Seconds, Loss Of Frame Count, and Slipped Seconds.

In ESF mode, these statistics are available to the system operator as well as to the carrier or service provider over the embedded 4 Kbps Facilities Data Link (FDL). Each ESF T1 facility can be independently programmed to support framing according to the AT&T 54016 standard or the ANSI T1.403 standard or both simultaneously. Additionally, for each T1 in the system, the operator may select an error rate threshold (from $10E4$ to $10E-9$) which, if exceeded, will cause the system to generate an Excessive Error Rate (EER) alarm.

6.6.2 DDS Line Performance Monitoring

The two port OCU-DP card supports two methods of non-intrusive error correction. The first is Majority Vote and applies to lower data rates such as 2.4, 4.8 and 9.6 Kbps. The other is the BCH method and applies to data rates of 19.2 Kbps and 56 Kbps.

If an OCU-DP port has error correction enabled, then the system will collect and display statistics on the performance of the circuit. Performance statistics include incoming (from the T1 network) and outgoing (to the 4-wire DDS circuit) Errored Seconds, Severely Errored Seconds and Consecutive Severely Errored Seconds and are displayed in one-hour intervals for the preceding twenty-four hours.

Chapter 7

System Cards

CPU Card

7.1 Introduction

The CPU is the “brain” of the Integrated Access System and performs most of the configuration, management, and common processing for the system. In addition the CPU card provides the interconnection of WAN/User/Server Pulse Code Modulation (PCM) buses through a bus connect or cross connect function. The Integrated Access System can have up to 2 CPU cards which provide a redundant control and switching complex. If the primary CPU fails, the standby takes over. A cross-connect for 256 DS0s is utilized on the IMACS to provide the user with complete flexibility for cross-connecting the available DS0's.

7.2 CPU Card Description

7.2.1 CPU XCON with Ethernet Port (880770)

The CPU XCON with Ethernet Port card controls the Integrated Access System. It performs the following functions:

- Initializes the system upon power-up, and runs a self-test on all cards plugged into the chassis at that time.
- Polls all cards in the system every second to determine their operating status.
- Processes all incoming operator commands and displays the responses in a series of operator interface screens for each card in the system. The operator interface system (local VT-100 terminal, remote computer, or network management system) connects to the Interface card, which sends these commands to the CPU card for processing.
- Includes circuitry that allows you to cross-connect DS0 time slots between T1 and E1 lines connected to the system WAN cards. Refer to the DS0 time slot assignment operations.
- Includes a test pattern generator for T1 and E1 line test purposes.

- Performs primary-secondary CPU arbitration. In a system with redundant CPU cards, the two CPU cards communicate their status to each other. If the primary CPU card fails, the redundant card takes over and becomes the primary.
- Enables Ethernet connection for remote management, configuration and downloading of host code via a 10baseT Ethernet port.

7.2.1.1 Card Jumper/Switch Settings

The CPU-7 XCON with Ethernet Port Card has no jumpers as illustrated in Figure 7-1.

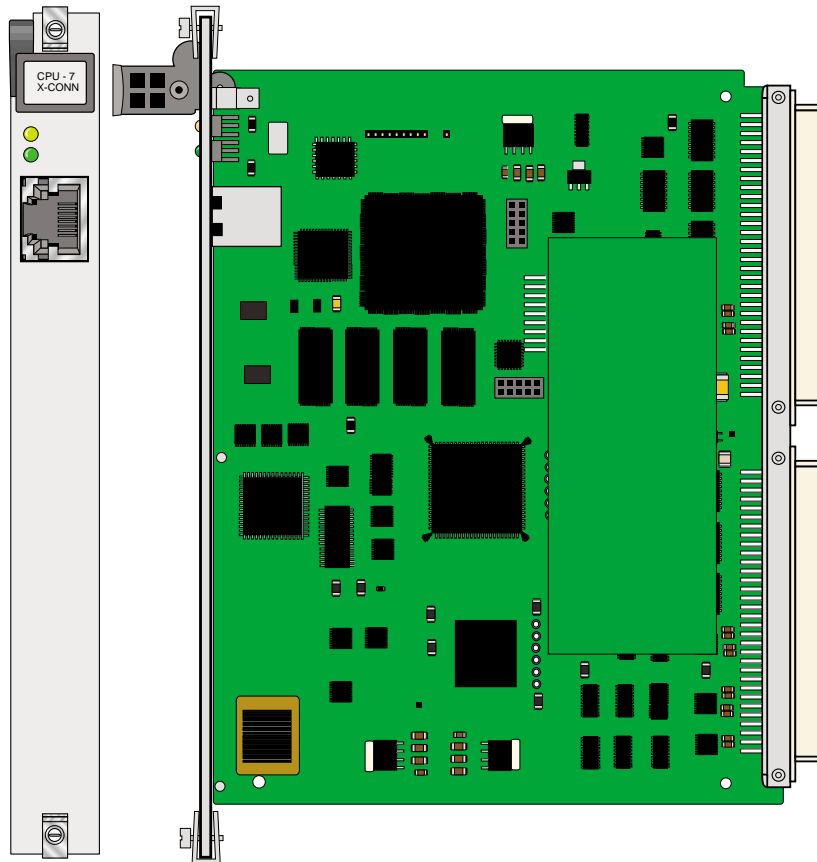

Figure 7-1.CPU-7 XCON with Ethernet Port

7.2.1.2 Installing the CPU-7 XCON with Ethernet Port Card

Install the CPU-7 XCON with Ethernet Port card into slot C1 of the system chassis. Install another identical 880770 card into slot C2. The card in slot C1 will be the primary, and the card in slot C2 will be the secondary. This CPU makes use of an FPGA (Field Programmable Gate Array) device, which takes approximately 35 seconds to load upon power-up. As a standby processor, the 880770 card will appear on the user interface map in an OOS state until the FPGA has been successfully loaded.



Note: *The PRM-880770 is a new processor for the IMACS system. It cannot be used with any other 880x processor card. Should anything other than a PRM-880770 be present in the adjacent C1 or C2 slot, switching over to the other processor will create data corruption, and will result in a system outage.*

7.2.1.3 Setting Up CPU Ethernet Port

To setup the CPU Ethernet port with the CPU-7 hardware, perform the following steps:

1. Access the CPU TCPIP screen and enter the following settings:
 - a. IP ADDRESS: [device IP address]
 - b. IP NETMASK: [IP mask]
 - c. DEFAULT IP PORT: nx64
 - d. DEFAULT IP UNIT: C1
2. Save the specified settings.
3. Access the nx64 screen using the "x" command and enter the following settings:
 - a. Set C1 to **actv**;
 - b. Set format to "**ether**";
4. Save the specified settings.
5. Return to the tcp/Ip screen by entering '**m**'
6. Set DEFAULT IP GATEWAY: [IP gateway address]
7. Save the specified settings.
8. From a PC on the same IP network, enter:
 - a. Ping [device IP address]
 - b. Telnet [device IP address]
9. From the IMACS:
 - a. Ping PC on IP network
10. From a PC on a different network than the IP network:
 - a. Ping [device IP address]

b. Telnet [device IP address]

11. From the IMACS, Ping PC on the network different from IP subnetwork.

Other settings are also possible, such as setting the host CPU to gateway, and then route Ethernet packets to a different IMACS across another nx64 port, FDL, SLIP/PPP or server card.



Note: *This feature is not intended to replace a standard router, such as the IMACS 881161 or 883160. This feature is for remote management, configuration and downloading of host code via a 10baseT Ethernet port.*



Note: *The CPU7 board (880770) should not be mixed in a shelf with any other CPU card. Automatic switching between the 880770 and any other CPU is not supported in the case of a hardware failure, and therefore a CPU7 system is only supported for redundancy when both CPU cards are 880770 packs.*

7.3 CPU Card User Screens and Settings

The CPU card has several user interface screens for card configuration and network status viewing purposes. These screens are described in the remainder of this chapter.

7.3.1 CPU Card Main Screen

Figure 7-2 shows the CPU Card Main Screen. You must configure the CPU card after logging into the system for the first time. To view this screen, highlight the desired CPU card in the System Main Screen and press <Enter>.

```

Node 121 | C2 CPU XCON Rev A1-0 Ser 00070 | 07-16-13 16:53
1
NODE ID      Node 121
SUPERUSER    Superuser
MANAGER      Manager
OPERATOR     Operator
VIEWER       Viewer
PUBLIC
SYS CONT.    System Contact
SYS LOC      System Location
SYS PH#
ALRM SEQ     all
ACO          latch
FCR          off

C2  Active   Host 7.2.1   Voice 7.2.1
C1  Redundant Host 7.2.1   Voice 7.2.1

Save | Undo | Refresh | Prt | tcp/Ip | usrNames | rAdius | Main

```

Figure 7-2.CPU Card Main Screen

The CPU card has numerous settings that you must configure. The CPU Main Screen displays the status of each CPU card (active or redundant), the type of card installed, and the host and voice software versions currently installed on that card. The settings are described in the next few sections of this chapter.

The bottom highlighted line of the above screen shows a series of actions you can perform in this menu. To perform an action, press the letter key associated with the uppercase letter of the desired action. For example, to save your card option settings after making them, press “s” to invoke the **Save** command. Table 7-1 lists and describes these actions.

Table 7-1. CPU Card Main Screen Actions

Action	Function
Save	Saves changes to settings.
Undo	Returns all settings to the last saved state.
Refresh	Updates certain time-related information fields that are not automatically updated (i.e., performance and test data).
Prt	Allows the user to print alarms to a remote device through the modem and/or the DB-9 computer port on the Interface Card. Refer to the "Printing Alarms Remotely" section later in this chapter.
tcp/Ip	Allows the user to configure for TCP/IP functionality.
usrNames	Manage the user names on the IMACs
radius	Enable and disable the Radius feature
Main	Returns you to the System Main Screen. If you made changes to any card settings but did not save them yet, you will be prompted to save or lose those changes before exiting.

7.3.2 RADIUS Authentication

Part of NERC conformity is the ability to have centralized password authentication and control. The basic way this feature works is that once enabled, all access into the IMACS shelf is done through a password validation with a single point of control, the RADIUS Authentication Server. Turning on this feature will deny all access to the IMACS unless approved by the authentication server. The password authentication includes encryption of the password string using the shared secret key. To enable the RADIUS authentication feature, carriage return on the active CPU, and select 'A' for RADIUS. A screen such as below will appear.

```

Node 121 | C1 CPU XCON Rev A0-0 Ser 00097 | 03-18-13 14:20
RADIUS Configuration
*
STATE      enabled
SERVER     192.68.16.1
FALLBACK   enabled
PORT       1812
TIMEOUT    77
RETRIES    6
SECRET     ThisStringAppliesSecretPasswordStringIntoTheEncryptionForProtect
Save | Undo | Refresh | Main

```

Figure 7-3. RADIUS options

To turn on RADIUS authentication, set the state to enabled. The user then needs to configure the following:

"**SERVER:** the IP address of the RADIUS server

"**FALLBACK:** see explanation below

"**PORT:** UDP port that the RADIUS server uses to receive authentication packets from its clients. The default is 1812.

"**TIMEOUT:** How many seconds the system will wait for a response from the RADIUS server. The default is 3.

"**RETRIES:** The number of attempts that the IMACS will try to authenticate the password if there is no response from the server. The default is 3.

"**SECRET:** This is the shared secret key between the IMACS and the RADIUS server. The secret key is a case-sensitive text string up to 64 characters long. The secret key on the server must match exactly the secret key on the IMACS. Along with alpha-numeric characters, these special characters are also allowed: ~!@#\$%^&*()_+|\='{}[]:"';<>?/.,

Fallback allows for access to the IMACS shelf from the console port should the RADIUS server not respond for whatever reason. The IMACS will then process username and password authentication locally, as if the RADIUS feature were not enabled. This is only true if RADIUS is turned on, fallback is enabled and the RADIUS server cannot be reached.

WARNING! Saving the RADIUS setup without fallback will from that point on require the RADIUS server to authenticate the user. Failure to have the server setup, or failure to be able to reach the server will deny the user access to the node. Zhone Technologies or its affiliates will not be able to grant access to the IMACS shelf.

For the server side, the following Vendor Specific Attributes (VSA) are required in order to authenticate the IMACS Radius authentication request:

Vendor ID: 5504

Attribute: Zhone-IMACS-User-Group

The Zhone-IMACS-User-Group is an integer value ranging from 1-32 and this correlates to the User Group Permissions as defined on the IMACS system.

When you define a user on the RADIUS server, you must also provide the Zhone-IMACS-User-Group attribute associated with that user in order for the IMACS system to pass the correct group privileges when the user logs into the system.

Following is an example from a FreeRADIUS server:

```
*****
```

dictionary file

```
=====
```

- add the following line to the dictionary file:

```
    $INCLUDE        dictionary.zhone
```

```
*****
```

dictionary.zhone file

```
=====
```

```
#####
```

```
# Zhone IMACS
```

```
#####
```

```
VENDOR Zhone      5504
```

```
BEGIN-VENDOR Zhone
```

```
ATTRIBUTE Zhone-IMACS-User-Group 1 integer
```

```
END-VENDOR Zhone
```

```
*****
```

users file

```
=====
```

- add the following lines to the user file, one for each user:

```
    frank Cleartext-Password := "frank"
```

```
    Zhone-IMACS-User-Group = 1
```

```
*****
```

clients.conf file

```
=====
```

- add the following lines to the clients.conf file, one for each system:

```
client 172.16.73.224 {
    secret = abcde12345
    shortname = franklyn
}
```

7.3.3 User Names, Passwords and Groups

Password updating is covered in Chapter 5. Refer to that chapter for full details on updating and maintaining user names and passwords. You may want to change your system access passwords frequently, in order to maintain optimum security on your network. The recommended passwords are a minimum of 6 and no more than 12 characters in length, are not found in a dictionary, and contain both letters and numbers. Because the system is case-sensitive for password entries, you can mix uppercase and lowercase letters to provide more possible passwords.

The user administration function is activated by entering 'n' for usrNames from the CPU Main screen, as shown in Figure 7-2 on page 7-6.

The system supports 256 possible users. Each user is defined by the use of three entries or fields. The fields are editable by a user who has Administrator or Superuser access. Following is a brief description to the user fields

7.3.3.1 Changing Your Passwords

The ability to update, delete and manage the passwords to the IMACS shelf is found under the userName level on the CPU screen and covered in chapter Section 5.3.3 on page 5-10.

Table 7-2. usrName Screen Actions

Action	Function
Refresh	Re-paints the current screen
Add	Allows you to add a user
Del	Allows you to delete a user
Group	Displays the Group settings and access level permissions.
Login Log	Provides the last 20 login and logout events.
pgup	Pages up
pgdn	Pages down.
Main	Returns you to the CPU Main Screen. If you made changes to any port settings but did not save them yet, you will be prompted to save or lose those changes before exiting.

Refresh

Selecting 'R' for refresh will renew the data presented on the screen.

Add

To add a user, choose the **A** function. Use carriage returns to update a field, and arrow keys to move around in the screen.

Del

Selecting the 'E' delete function will allow the user to delete the user that the cursor is currently positioned upon.

Group

Selecting 'G' will show the permissions for access to a Superuser that can be changed.

Login Log

Selecting 'L' will take the user to a screen where the login log is stored. This table is read-only, and will display the last twenty login and logout events. Figure 7-4 shows how a typical entry will appear.

ENTRY	USERNAME	LOGIN	STATUS	LOGOUT
1.	IPRTETH	01-08-13 14:01	cfg change	
2.	IPRTETH	01-08-13 14:04	cfg change	
3.	admin		timed out	01-08-13 14:32
4.	admin	01-08-13 14:59	logged out	01-08-13 15:01
5.	admin	01-08-13 15:07	logged in	
6.	IPRTPPP2	01-08-13 15:08	cfg change	
7.	admin		logged out	01-08-13 15:11
8.	admin	01-08-13 15:49	logged in	
9.	IPRTPPP2	01-08-13 15:49	cfg change	
10.	IPRTPPP2	01-08-13 15:49	cfg change	
11.	admin		logged out	01-08-13 15:50
12.	admin	01-08-13 16:32	timed out	01-08-13 16:47
13.	admin	01-08-13 17:22	logged out	01-08-13 17:23
14.	admin	01-08-13 17:27	logged in	
15.	IPRTPPP2	01-08-13 17:29	cfg change	
16.	IPRTPPP2	01-08-13 17:29	cfg change	

Refresh | pgUp | pgDn | Clear | Main

Figure 7-4. Login Log Sample Display

pgUp

Selecting the 'U' function will cause the screen to page up, if applicable.

pgDn

Selecting the 'D' function will cause the screen to page down, if applicable.

Main

Selecting the 'M' function will return the user back one level to the CPU Main Screen.

7.3.3.2 Other CPU Card Settings

You also must set the additional card parameters described below in the CPU Card Main Screen. Most of these are user-defined alphanumeric entries. To make new entries in these fields, first press <Enter> to highlight the current entry in the lower left of the screen. Then, type the new data on the keyboard. If you make a mistake, press either the backspace or <Delete> key to back up the cursor and erase the incorrect characters. Then, retype the correct characters. Finally, press <Enter> again to store the new entry in the field.

NODE ID

In this field, enter a 14-character node name for the Integrated Access System. This entry must be unique for each system in your network. It can have alphanumeric characters and spaces. The NODE ID string is used by SNMP as the .sysName.

SUPERUSER / MANAGER / OPERATOR

Each of these fields are treated identically within the IMACS for SNMP access levels. The each allow for a 14-character community string for verification purposes to be used for SNMP read/write access to the Zhone MIBS. These strings allow numbers, lower and uppercase letters as well as special characters.

VIEWER

In this field, enter a 14-character community string to be used for SNMP read only access to the Zhone MIBS. Allows numbers, lower and uppercase letters as well as special characters.

PUBLIC

In this field, enter a 14-character community string to be used for SNMP read access to the standard mib-2. Allows numbers, lower and uppercase letters as well as special characters. The default community string to grant access is all lowercase “public”, which allows for read-only access to standard mib-2. The IMACS default is all blank, which disallows public standard mib-2 access

SYS CONT

In this field, enter the name of a person to contact for questions about the Integrated Access System. This field can have up to 23 alphanumeric characters, including spaces. For convenience, use the system administrator’s name in this field.

SYS LOC

In this field, specify the location of the Integrated Access System. This field can have up to 23 alphanumeric characters, including spaces.

SYS PH#

Type the phone number of the Integrated Access System in this field. This phone number is used by a remote operator to access the system for a VT-100 session, via either ISDN D-channel dialing or a Remote IMACS Terminal System (RITS). You can enter up to 10 numeric characters in this field. However, do not include any dashes in this entry.

ALRM SEQ

The Alarm Sequence setting establishes how the sequence number for alarms is generated. Set this option to **all** if you want any alarm generated by the system to be assigned a sequence number. Or, set this field to **report** if you want only the alarms set to **report** to have sequence numbers.

ACO

The Alarm Cutoff (ACO) option reports a status to you based on the **latch** (condition held) or **cur** (current condition) setting.

FCR

FCR stands for Fast Circuit Restore, and will allow traffic circuits to restore activity after a T1 line failure faster than what is recommended in the T1 specification. This feature may have applications in 'protective relaying circuits', assuming that random data received during the period of the outage is acceptable

With FCR Off - Default

Integrated Access System operation follows the standard requirements of service restoration for failures. If a T1 line or WAN card fails, the system will generate either a red or yellow alarm and will clear CGA-RED and CGA-YEL alarms per standard definitions.

FCR On

With FCR On the Integrated Access System will bypass the standard equipment. The system will clear CGA-RED and CGA-YEL alarms immediately after a T1 frame is recovered. This will allow restoration of the voice and data circuits within 700 400ms.

7.3.4 Printing Alarms Remotely

Integrated Access Systems are typically placed in unattended locations (equipment closets, etc.). If no one is present to detect alarms that might occur, a system administrator has no way of knowing whether or not the system is working properly.

The solution to this network management problem is the Print Alarm feature. Each system unit can be programmed to call a predetermined telephone number at specific intervals and report the presence of selected system alarms. Choose alarms to print remotely by selecting the **Report** option in the alarm filters.

You can use either an external modem or the internal modem (2.4 kbps) on many of the Interface cards to send system alarms to a remote logging device, such as a printer or personal computer. If using the internal modem, the remote device should be connected to a V.22bis 2.4 kbps asynchronous modem set to auto-answer mode, eight data bits, one stop bit, and no parity. When the modem connected to the remote logging device answers, the system sends the alarm messages as a string of ASCII characters formatted with carriage returns and line feeds, then terminates the call. More information on this process can be found later in this chapter.

A network administrator can also call the phone number associated with the system modem and initiate a two-way, interactive VT-100 session with the system to determine the nature of the problem and dispatch technicians if necessary.

Another Network Management solution is the TCP/IP feature discussed later in this chapter. Note that **if the TCP/IP network management system is active, the Print Alarm feature will not operate.**

Using the TCP/IP feature automatically converts alarm messages into SNMP traps for forwarding to downstream NMS equipment.

To get to the CPU Print Alarm screen in Figure 7-5, press “**p**” to choose the **Prt** command from the CPU Card Main Screen.

```

Node 121 | C2 CPU XCON Rev A1-0 Ser 00070 | 07-16-13 17:08
          |
          | 1
PRT ALARMS      off
PRT PHONE#
PRT RETRY       1
PRT ATTEMPTS    1
PRT MAJ&CRIT    1
PRT MIN&INFO    1
ELEMENT 1       number
ELEMENT 2       alarm
ELEMENT 3       model
ELEMENT 4       address
ELEMENT 5       time
ELEMENT 6       severity
Save | Undo | Refresh | Main

```

Figure 7-5. Typical CPU Print Alarm Screen

Table 7-3 lists the operations that can be performed from the Print Alarm Screen above. These appear on the highlighted line at the bottom of the screen.

Table 7-3. Print Alarm Screen Actions

Action	Function
Save	Saves changes to settings.
Undo	Returns all settings to the last saved state.
Refresh	Used on Monitoring Screens to update statistics, and on other screens to redraw them.
Main	Returns to the CPU Card Main Screen. If changes are made to settings and not saved, you will be prompted to save or lose changes.

Table 7-4 summarizes the option settings for the CPU Print Alarm Screen. These settings are also described in the following paragraphs.

Table 7-4. Print Alarm Screen Options and Defaults

Parameter	User Options	Notes	Default
PRT ALARMS	off direct modem	1	off
PRT Phone#	telephone number (up to 14 numbers)		
PRT RETRY	1 to 60		1
PRT ATTEMPTS	1 to 99		1
PRT MAJ&CRIT	1 to 500		1
PRT MIN&INFO	1 to 32000		1
ELEMENT 1	alarm model address time severity number empty	2	number
ELEMENT 2	alarm model address time severity number empty	2	alarm
ELEMENT 3	alarm model address time severity number empty	2	model
ELEMENT 4	alarm model address time severity number empty	2	address
ELEMENT 5	alarm model address time severity number empty	2	time
ELEMENT 6	alarm model address time severity number empty	2	severity

Notes:

1. The Print Alarms option must be **off** if TCP/IP is **on**.
2. The choice of “empty” will eliminate that element from the NMS report.

PRT ALARMS

The Print Alarms option allows you to choose a remote device for alarm condition reporting. The system uses the modem (if present) on the Interface card to call a remote device or Network Management System. The system sends the alarm information for all alarm filters set to **Report** in the Alarm Filters screen. Refer to Chapter 4 *System Configuration and Operation*.

Set the Print Alarms setting to **off** to disable all external alarm-generated messages. Choose **direct** to send all alarms reported since the last report cycle to a local device through the DB-9 computer port of the Interface card. The **modem** setting sends all alarms reported since the last report cycle to a remote dial-up device through the modem port.

The remote device may be any asynchronous ASCII device that can accept lines of text up to 80 characters long. It must support XON/XOFF flow control and be capable of attaching to an asynchronous dial-up modem. Figure 7-6 shows an OOS alarm reported to a remote device.

The remote device's modem must be compatible with CCITT V.22bis and support connections at 2.4 kbps. Set the remote modem for auto-answer mode. **Both the remote device and modem should be set for 8 data bits, 1 stop bit and no parity.**

PRT PHONE#

The Print Phone Number field shows the number the modem dials to report alarms to the remote device. This number can be up to 14 digits long.

PRT RETRY

The Print Retry field specifies the amount of time the system will wait between attempts to redial the remote device. The retry interval can be from **1** to **60** minutes.

PRT ATTEMPTS

The Print Attempts field is the maximum number of times the system will try to contact the remote device before giving up. The number of attempts can be from **1** to **99**.

PRT, MAJ&CRIT

The Print Major field specifies the maximum amount of time the system will wait from the occurrence of a major alarm until it places a call to the external device to report it. This interval cycle can be from **1** to **500** seconds. All alarm reports designated as **Major** will be reported at that time. For example, if you specify an interval cycle of 5 minutes (300 seconds), every major alarm occurring during that interval will be reported at the end of that cycle.

The Print Major and Critical interval cycle starts from the most recent of:

1. The end of the last Major alarm cycle (if no alarms occur).
2. When parameters are saved using the Save command from the Menu of Actions.
3. Forty (40) seconds after the last alarm message is reported.

PRT MIN&INFO

The Print Minor field is the maximum time the system will wait from the occurrence of a minor alarm until it places a call to the remote device to report it. This interval cycle can be from **1** to **32,000** seconds. All alarm reports designated as **Minor** will be reported at that time. For example, if you specify an interval cycle of 60 minutes (3600 seconds), every minor alarm that occurs during that interval will be reported at the end of that cycle.

The Print Minor interval cycle starts from the most recent of any of the following:

1. The end of the last Minor alarm cycle (if no alarms occur).
2. When parameters are saved via the **Save** command from the Menu of Actions.
3. Forty (40) seconds after the last alarm message is reported.

When the specified interval cycle for major or minor alarms is reached, the system will send a list of the accumulated alarms sorted by the elements below. To avoid congestion, alarm reporting is limited at the remote device or Network Management System to the first 40 lines of non-reported alarms. The system will then wait 40 seconds and send the next 40 lines, and continue sending in that fashion (i.e., send 40 lines, wait 40 seconds) until it finishes the entire list of non-reported alarms. The next interval cycle starts 40 seconds after the last alarm message is reported.

ELEMENT 1-6

The Element 1 through Element 6 fields show the six alarm configuration elements (**alarm, model, address, time, severity, number, and empty**). These elements can be arranged in any user-defined order. For instance, one user may want the order of the alarm configuration to be severity, time, model, address, alarm, and number, while another user might prefer the sequence to be model, time, alarm, address severity, and number. Use the six Element fields to order these variables as desired.

Figure 7-6 shows a typical remote printout of alarms reported by an Integrated Access System. In this example, the Node Name (NO) is "Node_1," the Acknowledgment Number (AK) is 7, the Alarm Number (NU) is 38. This is an Out of Service alarm (AL = OOS); it was reported by a Model (ML) 8840 Card in chassis slot P2 (UN = P2). The alarm began on 3/20/96 at 14:44:12 (2:44 p.m.) and ended on 3/20/96 at 16:12:16 (4:12 p.m.). The Severity level of this alarm is Critical (SV = C).

```
NO=Node_1, AK=7,
NU=00038, AL=OOS, ML=8840, UN=P2, ON=03-20-96
14:44:12,
OF=03-20-96 16:12:16, SV=C
END
```

Figure 7-6. Typical Alarm Printout

7.4 TCP/IP Network Management

This section presents another type of Network Management System (NMS) for diagnosing and reporting trouble at unsupervised locations. The SNMP and TELNET configuration can connect using this alternate method. Both formats can use the 4 kbps FDL (Facility Data Link) of an ESF-framed T1 link, the SA4 on an E1 link, a Nx64 on a T1 or E1 link (see Section 7.5.1 on page 7-49), or the computer port of the Interface card via SLIP or PPP protocol.

If you do not understand the NMS concepts of IP addressing, SNMP, SLIP or PPP, TELNET, and Ping, please consult with your network administrator before attempting to install or repair components presented in this section.

If you have a small number of remote units to manage, one of the Network Management System options is to use a B7R (Bit-7 Redundant) card at the NMS site. Up to eight remote system units send alarm information on the FDL/SA4 of a T1/E1 link to either a DACSII™ or eight individual DS0s, and multiplex the contents into a single 38.4 kbps asynchronous circuit via the SLIP protocol. This data is used by a communication server or terminal server for routing to a Local Area Network.

If the FDL is used to transmit and receive information, a DACSII or DACSII ISX (3.0 or higher) is used to convert the FDL/IP information to a full DS0 time slot. On a point-to-point circuit, a DACSII™ is not needed. See Figure 7-7.

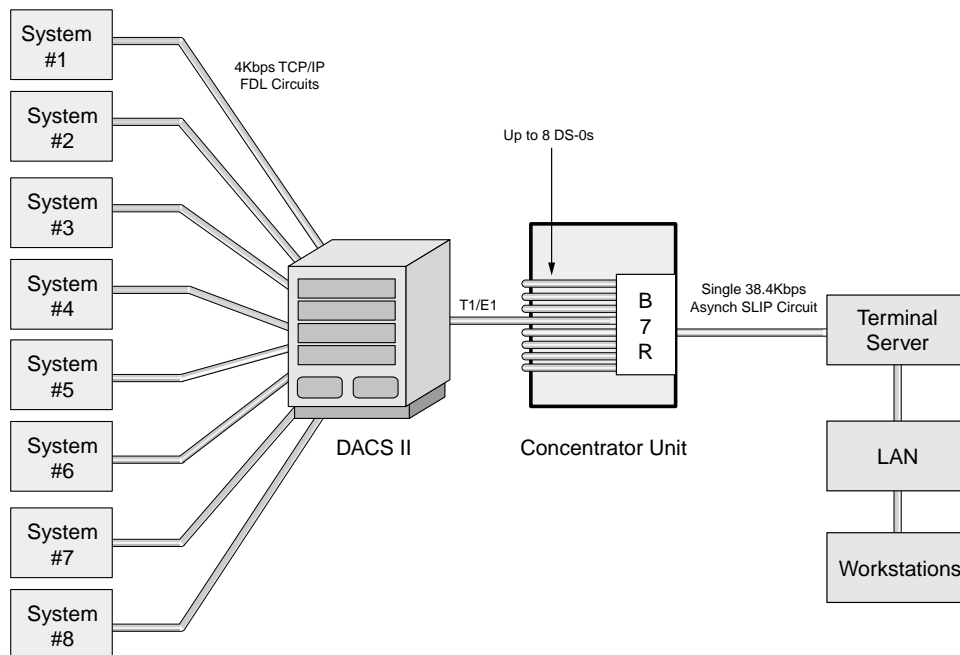

Figure 7-7. Typical TCP/IP Network Management System

Using IP addresses, you can communicate directly with the affected system, diagnose the problem, and dispatch a technician if necessary.

Figure 7-8 shows the TCP/IP Screen. To access this screen, press “**T**” (**tcp/Ip**) in the CPU Card Main Screen. Table 7-5 summarizes the actions that can be performed from this screen, and Table 7-6 lists the TCP/IP Screen parameters and options.

```
Node 121 | C2 CPU XCON Rev A1-0 Ser 00070 | 07-16-13 17:04
1
HOST IP STATE      actv
HOST IP ADDR      172.16.73.121
HOST NETMASK      255.255.255.0
HOST TYPE         host
DEFAULT IP PORT   nx64
DEFAULT IP SLOT   n/a
DEFAULT IP UNIT   C1
DEFAULT GATEWAY   172.16.73.254
RPT1 IP ADDR      0.0.0.0
RPT1 COMMUN STR
RPT2 IP ADDR      0.0.0.0
RPT2 COMMUN STR
RPT3 IP ADDR      0.0.0.0
RPT3 COMMUN STR
Ping | Netstat | rOute | Save | Undo | Refresh | nX64 | sysLog | Main
```

Figure 7-8. Typical TCP/IP Screen

Table 7-5. TCP/IP Screen Actions

Action	Function
Ping	Test whether the connected device responds to an echo request message. After entering the IP address of the host device, the status line will display, "Testing . . ." The next message indicates if the host is alive or down.
Netstat	Displays the Network Statistics. See below.
rOute	Shows the Routing screen. See the "Routing" section below.
Save	Saves changes to settings.
Undo	Returns all settings to the last saved state.
Refresh	Used on Testing and Monitoring screens to update statistics, and on other screens to redraw the screen.
nX64	Used for nx64 kbps HDLC/FR connectivity to other Integrated Access Systems as well as directly connecting to the MCC, IPR, FR at nx64 kbps.
sysLog	Access to turn on or off the syslog feature
Main	Returns to the CPU card main screen. If changes are made to settings and not saved, you will be prompted to save or lose changes.

Table 7-6. TCP/IP Screen Options and Defaults

Parameter	User Options	Default
HOST IP STATE	stdby actv	stdby
HOST IP ADDR	IP address	0.0.0.0
HOST NETMASK	Network	0.0.0.0
HOST TYPE	host gateway	host
DEFAULT IP PORT	none local wan servr nX64	none
DEFAULT IP SLOT	n/a local wan (w1, w2, w3, w4) servr (P1, P2, P3) nx64	n/a
DEFAULT IP UNIT	n/a 1-2 C1 C2 C3 C4	n/a
RPT1 IP ADDR	IP address	0.0.0.0
RPT1 COMMUN STR		blank
RPT2 IP ADDR	IP address	0.0.0.0
RPT2 COMMUN STR		blank
RPT3 IP ADDR	IP address	0.0.0.0
RPT3 COMMUN STR		blank

HOST IP STATE

This parameter determines whether TCP/IP is active or inactive. This is the master switch for the host IP stack, and is required to be set active in order for any IP communication to go through. The HOST IP STATE defaults to **stdby** (standby) prior to configuration. You must set it to **actv** (active) to enable TCP/IP.

HOST ID ADDR

The Host IP Address is the IP address for this specific system unit. If the B7R card is used for this NMS, the Port IP address must be the same as the one entered in the **ADDR** field of that card.

HOST NETMASK

The Host Netmask is used to indicate how much of the IP address is used for host addressing and how much is used for network addressing.

If the B7R card is used for this NMS, the CPU netmask address must be the same as the one entered in the **NETMASK** field of that card.

HOST TYPE

The Host Type is used to control IP forwarding. When Host Type is set to **gateway**, IP datagrams are allowed being forwarded. When Host Type is set to **host**, no forwarding is allowed. For IP forwarding (routing) to work correctly, a route must be created in the routing table.

DEFAULT IP PORT

The Default IP Port setting (Figure 7-9), tells the CPU card where IP packets will be sent when there is no matching entry in the routing table. The options are **none** (no default route used), **local** (SLIP/PPP over DB-9 serial port), **wan** (W1 W2 W3 W4) (FDL/SA4 or B7R [chosen on the WAN card main screen with ESF/NMS RPT option]) **servr** (P1 P2 P3) (WAN DS0s or Ethernet depending on type of server card) or **nX64** (C1, C2, C3, C4 WAN nx64 ports).

If this parameter is set to **local**, **wan** or **servr**, the Print Alarms feature (mentioned in the previous section) must be set to **off**. If **local** is chosen for this setting, the internal modem will not operate.

If this parameter is set to **nX64**, the default IP port selected is **nX64**, packets will be directed to one of the four nX64 ports selected (**C1**, **C2**, **C3** or **C4**). (Refer to Default IP Unit below).

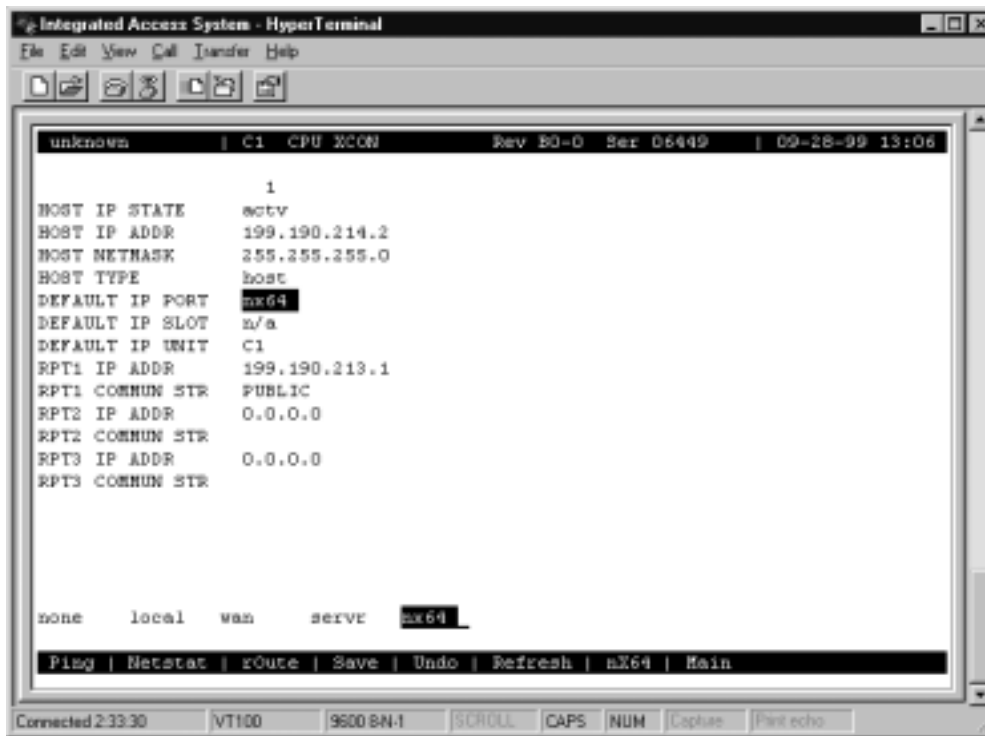

Figure 7-9.CPU Default IP Port Selection Screen

DEFAULT IP SLOT

The Default IP Slot options are determined by the choice of Default IP Port. If **off** or **local** is selected for that parameter, this option will show **n/a**. If **wan** is selected, the options for this parameter will show **W1-W4** (the WAN card slot that transmits and receives NMS information). If **servr** is chosen, the options for this parameter will show **P1-P3** (the server card slot that transmits and receives NMS information).

The Default IP Slot option is not used when default IP port is set to **nX64**.

DEFAULT IP UNIT

The Default IP Unit (Figure 7-10) options are determined by the choice of Default IP Port. If **off** or **local** is selected for that parameter, this option will show **n/a**. If **wan** is selected above, the options for this parameter will be **1-2** (corresponding with the WAN port). If **nX64** is selected above, the options for this parameter will be **C1, C2, C3 and C4**.

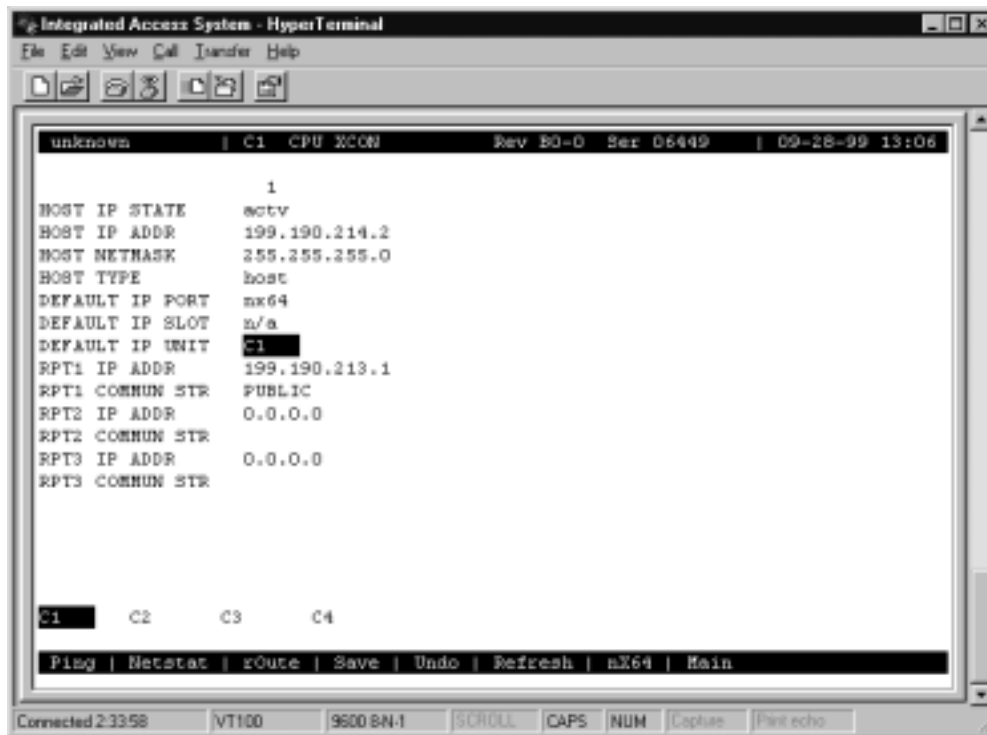

Figure 7-10.CPU Default IP Unit Selection Screen

RPT1 IP ADDR

The RPT1 IP Address is the IP address of the first Network Management System host running an SNMP trap server.

RPT1 COMMUN STR

The RPT1 Community String holds the community string for the first NMS host running a SNMP trap server. The community string provides additional security by rejecting messages that do not contain the correct string. *There must be some entry in this field to enable RPT1.*

RPT2 IP ADDR

The RPT2 IP Address is the IP address of the second Network Management System host running a SNMP trap server.

RPT2 COMMUN STR

The RPT2 Community String holds the community string for the second NMS host running a SNMP trap server. The community string provides additional security by rejecting messages that do not contain the correct string. *There must be some entry in this field to enable RPT2.*

RPT3 IP ADDR

The RPT3 IP Address is the IP address of the third Network Management System host running an SNMP trap server.

RPT3 COMMUN STR

The RPT3 Community String holds the community string for the third NMS host running a SNMP trap server. The community string provides additional security by rejecting messages that do not contain the correct string. *There must be an entry in this field to enable RPT3.*

7.4.1 SYSLOG

SYSLOG allows the user to set up a device that collects all alarms, logs and events from any number of IMACS shelves. This capability delivers on yet another NERC requirement for logging. Included in the log are not only system events of a spontaneous nature, but also security events such as login and logout and provisioning changes saved by a user. Any number of SYSLOG servers exist, many of them free. Most servers allows the user to configure the device to also generate save files, so that historical events can also be viewed.

To setup up the SYSLOG service on the IMACS, the user must log in with administrative privileges. Position on the active CPU, and press carriage return. On the CPU XCON screen, then hit 'I' for tcp/Ip and the screen below will appear.

```

:
node 13 | C2 CPU XCON Rev A1-0 Ser 00070 | 03-18-13 11:59
      1
HOST IP STATE      actv
HOST IP ADDR       172.16.73.13
HOST NETMASK       255.255.255.0
HOST TYPE          host
DEFAULT IP PORT    nx64
DEFAULT IP SLOT    n/a
DEFAULT IP UNIT    C1
DEFAULT GATEWAY    172.16.73.254
RPT1 IP ADDR       0.0.0.0
RPT1 COMMUN STR    Manager
RPT2 IP ADDR       0.0.0.0
RPT2 COMMUN STR
RPT3 IP ADDR       0.0.0.0
RPT3 COMMUN STR
Ping | Netstat | r0ute | Save | Undo | Refresh | nX64 | sysLog | Main

```

Figure 7-11.SYSLOG server level

Once at this level, simply hit 'L' to access the SYSLOG server setup screen, as shown in the following illustration.

```

node 13 | C2 CPU XCON Rev A1-0 Ser 00070 | 03-18-13 12:03
      1
SYSLOG STATE      actv
SYSLOG IP ADDR1   172.16.72.82
SYSLOG IP ADDR2   172.16.73.213
Save | Undo | Test | Refresh | Main

```

Figure 7-12.SYSLOG level

The user can then activate the feature, and input up to two devices for event collection. Use of the SYSLOG feature does require the use of IP addressing, so an IP network to the IMACS must be established and maintained. Once established, the facility above allows for the generation of a test message to be sent to the SYSLOG collector, to confirm connectivity. Below is the result of that test using the 3CDaemon tool:

daemon				
w Help				
	Time	IP Address	Msg Type	Message
TFTP Server	Mar 18 12:09:14	172.16.73.13	user.info	Test Log
FTP Server	Mar 18 12:09:06	172.16.73.13	auth.notice	CONF SYSL 03-18-13 12:08 cfg change
Syslog Server	Mar 18 12:08:35	local	user.info	Listening for Syslog messages on IP address: 172.1

Figure 7-13. SYSLOG server test log result

As seen above, the SYSLOG information includes the date and timestamp information. The following illustrations show some of the various types of events noted. This is not meant to be an exhaustive list, but representative of the types of data captured by SYSLOG. Table 7-7 shows various CPU activities, as well as card loading events.

Table 7-7. SYSLOG CPU / Loading events

Auth.Info	ACTVSW switch C1 to bank B1
Auth.Info	CARD P1 FLASH loaded XPRESS IP: 172.16.72.99 Name: iprtr_2.0.00.bin
Auth.Info	CARD P1 FLASH XMODEM started
Auth.Info	CARD P2 FLASH loaded IP: 172.16.72.99 Name: ab2_105.bin
Auth.Info	CARD U2 FLASH loaded IP: 172.16.72.148 Name: ohsu4_101.bin
Auth.Info	CPU C1 FLASH CKSUM 0x07b44425 loaded IP: 172.16.72.99 Name: a_7_b2.bin
Auth.Info	CPU C1 FLASH XMODEM started
Auth.Info	CPU C1 switch to bank B2
Auth.Info	CPU SWITCH MANUAL to slot C1
Auth.Info	NVRAM backup ascii
Auth.Info	NVRAM backup to flash
Auth.Info	NVRAM backup xmodem
Auth.Info	NVRAM restore from ascii
Auth.Info	NVRAM restore from flash
Auth.Notice	CONF NVRAM Restore 12-21-12 09:39 cfg change
Auth.Info	NVRAM tftp backup IP: 172.16.72.99 Name: DB_176_1219_timext.db
Auth.Info	NVRAM tftp restore flash IP: 172.16.72.99 Name: DB_176_1219_timext.db
Auth.Info	NVRAM xmodem restore to flash started
Auth.Notice	REBOOT admin MANUAL OOS reboot
Auth.Info	AMT REMOTE retrieve IP: 172.16.72.99 Name: a_xmod_0611_4.db
Auth.Info	AMT REMOTE backup IP: 172.16.72.99 Name: a_rnamt_0612_2.db
Auth.Info	AMT ACTIVE backup IP: 172.16.72.99 Name: a_amt_0612_2.db
Auth.Info	AMT ACTIVE restore IP: 172.16.72.99 Name: a_amt_0611_2.db

Table 7-8 below illustrates alarm events that are raised or cleared on the IMACS CPU-7 shelf.

Table 7-8. SYSLOG Alarm Indications

Syslog.Error	CLEAR: 01487 W1 DSX+DSX M OOS
Syslog.Error	RAISE: 01487 W1 DSX+DSX M OOS
Syslog.Warning	RAISE: 01530 W1-2 DSX+DSX m LOS
Syslog.Error	RAISE: 01531 W1-1 DSX+DSX M CGA_RED
Syslog.Info	RAISE 011338 C2 CPU XCON I OOS

Following in Table 7-9 are notifications in the SYSLOG feature of configuration changes. The following table will report for different entities, such as (but not limited to): **BRIDGE, EM, FXS, FXO, HSU, OHSU, SRU, WAN, INTFS, IPTRMAIN, ITCP, MCC, NODE, NVRAM, SCC** and **USRADMIN**.

Table 7-9. SYSLOG Configuration Change Notifications

Auth.Notice	CONF FXS 01-02-13 09:43 cfg change
Auth.Notice	CONF SRU 01-02-13 09:43 cfg change
Auth.Notice	CONF USRADMIN 01-02-13 09:40 cfg change
Auth.Notice	CONF REM_AMT 06-12-13 04:51 cfg change
Auth.Notice	CONF ACT_AMT 06-12-13 04:51 cfg change
Auth.Info	AMT ACTIVE copy BASE MAP to AMT MAP
Auth.Info	AMT switch back to main map
Auth.Info	AMT switch to alternate map
Auth.Info	AMT switch triggered by WAN alarm
Auth.Info	RADIUS disabled
Auth.Info	RADIUS enabled
Auth.Alert	RADIUS server unreachable for USERID: admin

And finally, tracked by the SYSLOG feature are events spurred by provisioned users accessing the system, or attempting to do so.

Table 7-10. SYSLOG USER ID tracking

Auth.Notice	USERID admin 12-21-12 14:00 timed out
Auth.Notice	USERID scott 12-21-12 13:25 logged in
Auth.Alert	USERID scott failed login

7.4.2 Network Statistics Screens

The Network Statistics Screens provide maintenance and diagnostic information for the different protocols supported by this equipment. The system starts accumulating statistics when the TCP/IP Port is changed from **off** to **local** or **wan**, and it continues to store information until it is turned off.

Figure 7-14 shows the first of four Network Statistics Screens, and Figure 7-15 through Figure 7-17 show the other three screens. To go to the first screen, press “**n**” in the TCP/IP Screen to choose **Netstat** from the bottom line of that screen. Table 7-11 lists the actions that can be taken from the Network Statistics Screens, and the following paragraphs describe the parameters in each screen.



Figure 7-14. Typical Network Statistics Screen, Page 1

To move from one screen (page) to another, press “**d**” (**pgDn**) or “**u**” (**pgUp**). Pressing “**d**” goes to the next-highest page number. If you are on Page 4 when you press “**d**”, you will wrap around to Page 1. Pressing “**u**” goes to the next-lowest page number. If you are on Page 1 when you press “**u**”, you will wrap around to Page 4.

Table 7-11. Network Statistics Screen Actions

Action	Function
pgUp	Scrolls backward through network statistics, one page at a time. If you are on the first screen (Page 1), automatically “wraps around” back to the fourth screen (Page 4).
pgDn	Scrolls forward through network statistics, one page at a time. If you are on Page 4, automatically “wraps around” back to Page 1.
Refresh	Since the system does not update statistics automatically, the Refresh command must be used to update information in statistics fields.
Main	Returns to the TCP/IP Screen. If changes are made to settings and not saved, you will be prompted to save or lose changes.

7.4.2.1 SLIP Parameters

The Serial Line Interface Protocol (SLIP) parameters appear in the first Network Statistics Screen (Figure 7-15). These are described below.

MTU Size

The MTU (Maximum Transmission Unit) Size field shows the largest number of user-data (e.g., the largest size packet) that can be sent in a single frame. The MTU for this system is 240 bytes.

Bytes Received

The Bytes Received field shows the number of bytes received by the local system from the network host.

Packets Received

The Packets Received field shows the number of packets (unit of bytes, roughly similar to an IP datagram) received by the local system from the network host.

Packets Discarded

The Packets Discarded field shows the number of packets sent by the network host that were discarded by the local system. Packets are discarded because they either exceed the MTU or are not complete.

Packets Dropped - Buffer

The Packets Dropped - Buffer field shows the number of incoming packets that were dropped because there was not enough free memory to buffer them.

Buffer Overflow

The Buffer Overflow field shows the occurrences of buffer overflow at the local system.

Packets Sent Out

The Packets Sent Out field shows the number of packets transmitted by the local system to the network host.

Bytes Sent Out

The Bytes Sent Out field shows the number of bytes transmitted to the network host by the local system.

7.4.2.2 FDL Parameters

The FDL parameters also appear in the first Network Statistics Screen (Figure 7-14). They are described below.

MTU Size

The MTU (Maximum Transmission Unit) Size field shows the largest number of bytes that can be sent in a single frame. The default MTU is 240 bytes.

Frames Received

The Frames Received field shows the number of frames received by the local system from the network host.

Frames Aborted on Receive

The Frames Aborted on Receive field shows the number of frames that were aborted when received by the local system from the network host. Frames are aborted because they either exceed the MTU or are not complete.

Frames to Transmit from Above

The Frames to Transmit from Above field shows the number of frames that were sent by the local system to the TCP layer of the network host.

Frames Transmitted

The Frames Transmitted field shows the number of frames sent from the local system to the network host.

Frames Aborted on Transmit

The Frames Aborted on Transmit field shows the number of frames aborted when transmitted by the local system to the network host. Frames are aborted because they either exceed the MTU or are not complete.

7.4.2.3 IP Parameters

The IP parameters appear in the second Network Statistics Screen (Figure 7-15). These are described below.

The screenshot shows a HyperTerminal window titled "Integrated Access System - HyperTerminal". The window displays the output of a NETSTAT command, specifically Page 2 of 4. The output is as follows:

```

unknown | C1 CPU XCON Rev B0-0 Ser 06449 | 09-20-99 13:00

NETSTAT Page 2 of 4

Default TTL                IP                255
Datagrams Received         0
Datagrams Discarded        0
Datagrams Delivered Above  0
Datagrams From Above       0
Datagrams Sent             0
TX Discarded - RAM         0
TX Discarded - mailbox short 0
TX Discarded - other       0

ICMP
Messages Sent              0
Echo Requests Received     0
Echo Replies Sent          0
Echo Requests Sent         0
Echo Replies Received      0
Dest Unreachable Sent     0

pgUp | pgDn | Refresh | Main
Connected 2:35:34 VT100 9600 8N-1 SCROLL CAPS NUM Capture Pass echo

```

Figure 7-15. Typical Network Statistics Screen, Page 2

Default TTL

The Default TTL field shows the Time To Live for information packets from transmission to delivery. The TTL for this system is 255 seconds.

Datagrams Received

The Datagrams Received field shows the number of IP datagrams (packets) received by the local system from the network host.

Datagrams Discarded

The Datagrams Discarded field shows the number of datagrams that were discarded by the local system.

Datagrams Delivered Above

The Datagrams Delivered Above field shows the number of datagrams sent to the TCP layer of the network host to the local system.

Datagrams From Above

The Datagrams From Above field shows the number of information or traps sent by the local system to the UDP or TCP layer of the network host.

Datagrams Sent

The Datagrams Sent field shows the total number of datagrams sent by the local system to the network host.

TX Discarded - RAM

The TX Discarded - RAM field shows the total number of datagrams sent by the local system that were discarded due to lack of free RAM memory.

TX Discarded - Mailbox Short

The TX Discarded - mailbox short field shows the total number of datagrams aborted by the local system because of a mail subsystem overflow.

TX Discarded - Other

The TX Discarded - other field shows the total number of datagrams discarded due to other causes.

7.4.2.4 ICMP Parameters

The ICMP parameters also appear in the second Network Statistics Screen (Figure 7-15). They are described below.

Messages Sent

The Messages Sent field shows the number of ICMP messages sent by the local system to the network host.

Echo Requests Received

The Echo Requests Received field shows the number of "ping" message requests received by local system by the network host. This figure is part of the total messages received.

Echo Replies Sent

The Echo Replies Sent field shows the number of "ping" message requests transmitted to the network host. This figure is part of the total messages sent.

Echo Requests Sent

The Echo Requests Sent field shows the number of "ping" requests sent to the network host by the local system. This figure is part of the total messages sent.

Echo Replies Received

The Echo Replies Received field shows the number of "ping" message replies received by the local system. This figure is part of the total messages received.

Destination Unreachable Sent

The Destination Unreachable Sent field shows the number of ICMP messages that were discarded upon receipt by the network host because they were improperly addressed.

7.4.2.5 TCP State Parameters

The TCP state parameters appear in the third Network Statistics Screen (Figure 7-16). They are described below.



Figure 7-16. Typical Network Statistics Screen, Page 3

Packets Received

The Packets Received field shows the number of TCP packets received by the local system from the network host.

Packets Discarded - Checksum

The Packets Discarded - Checksum field shows the number of TCP packets that were discarded by the local system because the checksum failed.

Packets Discarded - Port

The Packets Discarded - Port field shows the number of TCP packets that were discarded by the local system because the port assignment was incorrect.

Packets Discarded - Window

The Packets Discarded - Window field shows the number of TCP packets that were discarded by the local system because the window data was incorrect.

Bytes Delivered Above

The Bytes Delivered Above field shows the number of information or traps sent from TCP layer of the network host to the local system.

Bytes From Above

The Bytes From Above field shows the number of information or traps sent to the TCP layer of the network host from the local system.

Packets Sent

The Packets Sent field shows the total number of TCP packets that were transmitted to the network host by the local system.

ACKs Received

The ACKS Received field shows the total number of acknowledgments that were received by the local system from the network host.

Packets Sent - Reset

The Packets Sent - reset field shows the total number of TCP packets that were transmitted by the network host to the local system.

Packets Sent- ACK

The Packets Sent - ACK field shows the total number of TCP acknowledgment packets that were transmitted by the network host to the local system.

Packets Retransmitted

The Packets Retransmitted field shows the total number of TCP packets that were retransmitted by the local system to the network host.

RTT Increased

The RTT Increased field shows the number of times the retransmission time-out was increased because the system was busy.

RTT Decreased

The RTT Decreased field shows the number of times the retransmission time-out was decreased because the system was not busy.

Connections Opened

The Connections Opened field shows the total number of connections that were opened by the local system to the network host.

Connections Closed

The Connections Closed field shows the total number of connections that were closed by the local system to the network host.

Connections Aborted

The Connections Aborted field shows the number of times the connection was aborted because either the number of consecutive retransmissions was equal to 10 or retransmission time-out was equal to 15 minutes.

Packets TX Aborted - RAM

The Packets TX Aborted - RAM field shows the total number of packets sent by the local system which were aborted because of the lack of free RAM memory.

7.4.2.6 UDP Parameters

The UDP parameters appear in the fourth Network Statistics Screen (Figure 7-17). They are described below.



Figure 7-17. Typical Network Statistics Screen, Page 4

Packets From Above

The Packets From Above field shows the number of UDP packets sent by the local system to the network host.

Packets Sent

The Packets Sent field shows the number of UDP packets transmitted from the local system to the network host.

7.4.2.7 TELNET Parameters

The TELNET parameters also appear in the fourth Network Statistics Screen (Figure 7-17). They are described below.

Bytes Received

The Bytes Received field shows the total number of bytes that were received by the local system from the network host.

Bytes Receive as Commands

The Bytes Received as Commands field shows the total number of bytes that were received as commands by the local network from the network host.

Bytes Delivered Above

The Bytes Delivered Above field shows the total number of bytes that were transmitted by the network host to the local system.

Bytes Replied as Commands

The Bytes Replied as Commands field shows the total number of bytes that were transmitted as commands by the local system to the network host.

Bytes From Above

The Bytes From Above field shows the total number of bytes that were received by the network host from the local system.

Bytes Sent

The Bytes Sent field shows the total number of bytes that were transmitted by the local system to the network host.

Sessions Opened

The Sessions Opened field shows the total number of sessions that were opened by the local system with the network host.

Sessions Closed

The Sessions Closed field shows the total number of sessions that were closed by the local system with the network host.

TX Wait for Buffer

The TX Wait for Buffer field shows the total number of transmissions that were delayed by the local system for free memory in the buffer.

7.4.2.8 SNMP Parameters

The TELNET parameters also appear in the fourth Network Statistics Screen (Figure 7-17). They are described below.

PDU Sent

The PDU Sent field shows the number of Protocol Data Units sent from the local system. A Protocol Data Unit is a data object exchanged by protocol drivers, usually containing both protocol control information and user data.

Traps Sent

The Traps Sent field shows the total number of SNMP traps that were transmitted by the local system to the network host.

7.5 IP Packet Routing

The Integrated Access System supports multipoint routing of Internet Protocol (IP) between all of its interfaces. These are: Serial Computer Port Interface, Server card interface (service depends on type of card), 4 nx64 interfaces, and 8 WAN interfaces using FDL or B7R time slot 24 of a D4-framed T1 link, or the Facility Data Link (FDL) of an ESF-framed T1 link. For E1 links IP datagrams are forwarded using time slot 31 or the SA4 (national) bit.

To use B7R, FDL, or SA4, you must make an additional selection on the associated WAN card. For T1 links, the selection is made via the ESF/NMS RP parameter. For E1 links, it is made via the COM/NMS RP parameter. Refer to WAN Card and B7R Card Chapters for further information.

All packets arriving on any of the optional paths or the local port will be treated by the IP stack as follows:

- If the packet's destination address matches that system's address, the packet is processed locally.
- If the address is not the same, the unit will search the routing table to find a remote address that matches the destination of the packet.
- If a match is not found for the packet, it is routed to the interface specified in the DEF DEST field. If the default destination matches the interface the packet arrived from, the packet is dropped.
- IP datagrams generated as a response to a request is sent back on the same interface it was received from. For this reason, 'ping' may work without even though the routing table is not set up.

Figure 7-18 shows a typical routing arrangement. Although 24 units are used in this example, the number of remote units is unlimited except for bandwidth and link-down considerations.

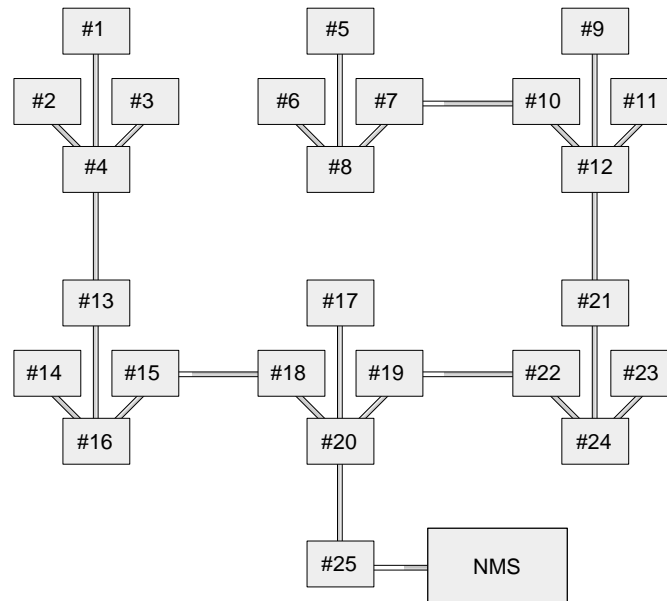

Figure 7-18. Typical Routing Diagram

In Figure 7-18, 24 system units transmit alarm information to an IP routing system unit (System 25) via the optional paths of separate WAN links. The network administrator assigns IP addresses for each system on the TCP/IP screen of each system's ICPU card (HOST IP ADDR). System 20 is connected by any of the optional paths to System 25, which supports NMS equipment (the communications server) with either a local SLIP connection directly from the CPU card or any optional path of a T1 or E1 WAN link. In this example, all alarms received by any of the system units will be forwarded via system 25 to the NMS over a single WAN link.

Each of the 24 reporting units use NMS's IP address as the RPT1 IP ADDR on the TCP/IP screen of its CPU card.

The local port is included to be able to transmit the IP packets generated by the routing unit to the same destination. In most cases, the DEF DEST of all units controlled by this router will be the same place (either the local port or optional WAN paths to a distant location).

The Routing screen column headings are associated with the incoming WAN link associated with the IP location of the remote systems. For example, if you expect incoming information from system 1 on WAN 1-1, you assign the IP address for system 1 IP NET for WAN 1-1.

Figure 7-19 shows the Routing Screen, and Table 7-12 lists the actions that can be performed from that screen. Table 7-13 summarizes the available option settings and defaults for that screen.



Figure 7-19. Typical IP Routing Screen

Table 7-12. Routing Screen Actions

Action	Function
Save	Saves changes to settings.
Refresh	Used on Testing and Monitoring screens to update statistics and on other screens to redraw the screen.
Add	Open the data entry screen to add a route
dEl	Delete a route
Get	Get information on routing destinations
PgUp	Go to a previous page of routing paths
PdDn	Go to the next page of routing paths
Main	Returns to the CPU card main screen. If changes are made to settings and not saved, you will be prompted to save or lose changes.

Table 7-13. Settings for Routing Parameters

Parameter	User Options	Default
IP NET	a valid IP address	0.0.0.0
SUBNETMASK	a valid Netmask IP address	0.0.0.0
SLOT/UNIT	wan: W1-1 through W4-2 serv: P1-P3 user: not supported local: COMP nX64: C1 through C4	w1-1

IP NET

The IP Net field shows the IP address of a device located on this system unit. This must be a valid IP address.

SUBNETMASK

The Remote Netmask field shows the Netmask of a device located remotely from this system. Any valid Netmask is acceptable. The remote netmask information is the same as that placed on the remote unit's TCP/IP screen.

SLOT/UNIT

The Default Destination specifies where to route packets received from a remote device and the routing device to downstream NMS equipment (either the optional paths of a WAN link or the local SLIP port).

Adding Routes

In the Routing Screen, type "a" (**Add**) to present a data entry screen. A data line appears near the bottom of the screen for the three address parameters of Table 7-13. Use the right/left arrow keys to move to the desired field. Press <Enter> to present the corresponding data entry field (Figure 7-20). Type in the correct address parameters, up to three digits (0-255) in each segment of the address, using the right arrow key to move to the next segment. Press <Enter> again to move the entered address into the data line. Use the left/right arrow keys to move on to the SubNet Mask and repeat the process. The Slot/Unit field offers the entry categories shown in Figure 7-21. Scroll to the desired category and press <Enter> to present one of the choices shown in Table 7-14. Scroll to the desired value and press <Enter>. When valid address and destination parameters have been added, type "s" to **save** the address (Figure 7-22). The system will not save an invalid address. To exit the Add screen without saving press the up or down arrow keys.

Delete a Route

In the Routing Screen, scroll to the route to be deleted. With the route highlighted, press **e** to delete.

Get Information

To obtain addressing information, press **g** for Get. The system displays the destination variables wan, serv, user, and local across the bottom of the screen. Use the left/right arrow keys to scroll to the desired destination and press <Enter> to select. The choices available under each of these options are then displayed. Now highlight the desired option and press <Enter> again to initiate the search. The system responds:

```
Sending RIP Request. Please wait ...  
Press any key to cancel
```

After the system send RIP request, the IP Static Routing screen will return, displaying valid IP Net (address), SubNetMask, and Slot/Unit information.

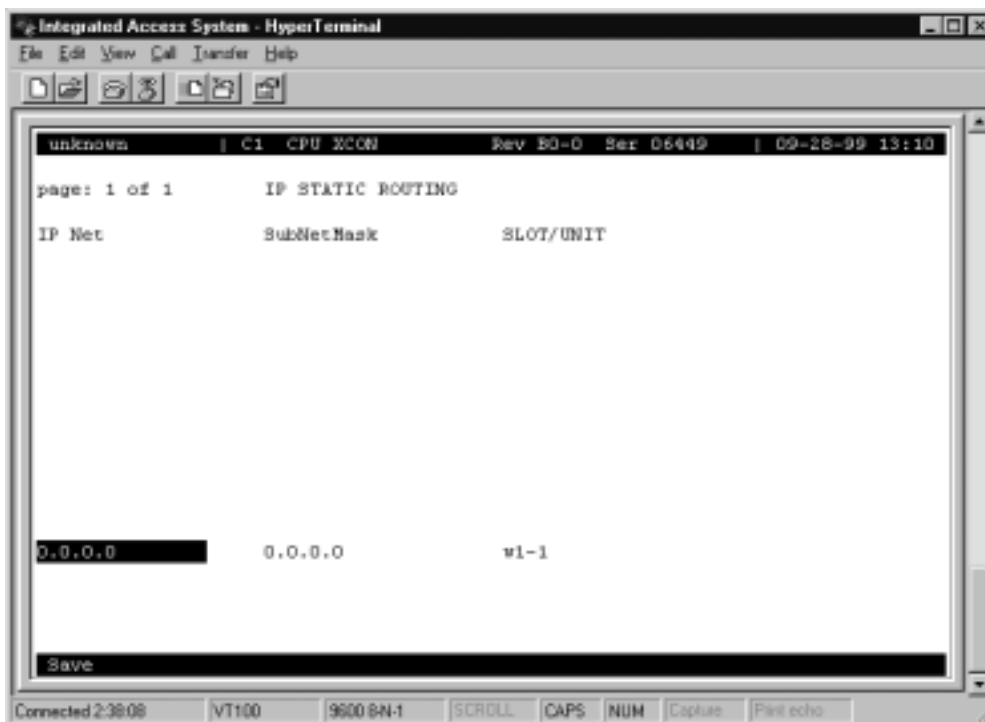

Figure 7-20. Routing Address Entry Screen

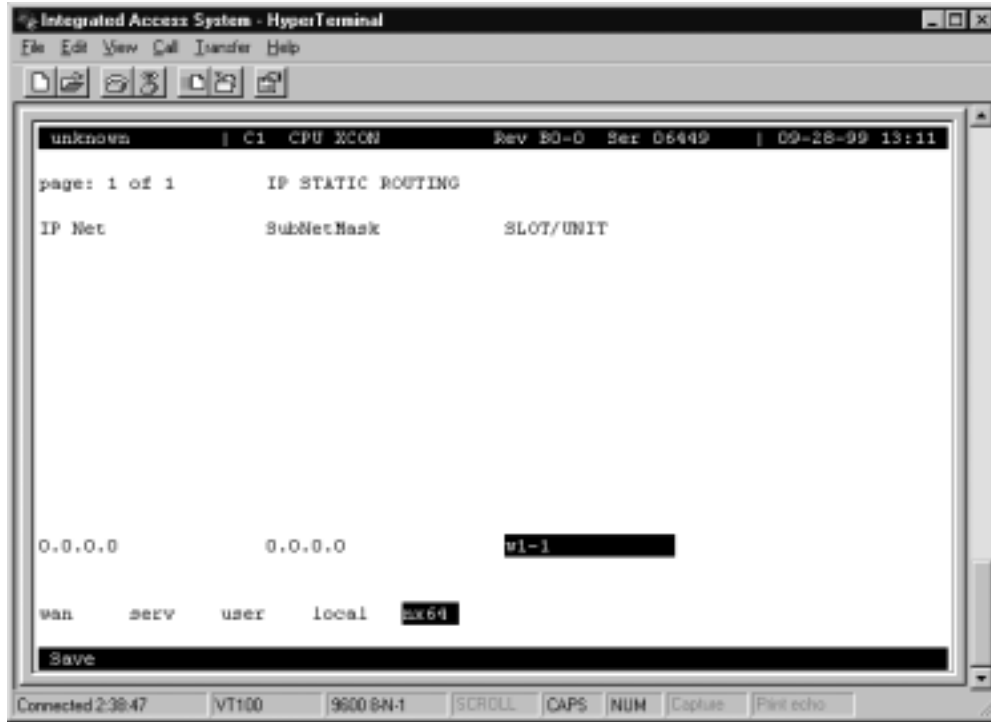

Figure 7-21. Slot/Unit Options Screen

Table 7-14. Slot/Unit Options

Slot/Unit Options	Description	Default
WAN	w1-1 w1-2 w2-1 w2-2 w3-1 w3-2 w4-1 w4-2	w1-1
SERV	P1 P2 P3	P1
USER	not supported	n/a
LOCAL	IF-2	IF-2
nX64	C1 through C4	C1



Figure 7-22.IP Static Routing Information Screen

7.5.1 nX64 Screen

The Enhanced NMS Connectivity screen (Figure 7-23) provides a solution to increase bandwidth channel for management purposes. FDL was previously the answer to this need for not consuming valuable bandwidth. However, by giving up a time slot the increase of bandwidth provided better connectivity allowing a variable bandwidth from 56 Kbps to 1.54 Mbps for T1 and 2 Mbps for E1. A single 1x64 Kbps channel improves the bandwidth over FDL 16 times.

	C1	C2	C3	C4
STATE	stdby	stdby	stdby	stdby
WAN	none	none	none	none
TS	n/a	n/a	n/a	n/a
FORMAT	hdlc	hdlc	hdlc	hdlc
RATE	64k	64k	64k	64k
NTU	240	240	240	240

Figure 7-23.nX64 Main Screen

The 5.x CPU includes four controllers for use in various types of communication. All four controllers are mapped through two TSA (Time Slot Assigner) devices and will share a common pool of 64 time slots. The TSAs are cross-connected to the TDM (Time Division Multiplexing) bus via MTUSs (Memory Time Switches).

Currently, the four nx64 ports can only be assigned to WAN resources.

The four available channels may be configured at nx64 kpbs, using plain HDLC for communication with other Integrated Access Systems, or using RFC1490 encapsulation for connectivity to other Integrated Access Systems as well as the Frame Relay public network.

Table 7-15. nX64 Screen Actions

Action	Function
Save	Saves changes to settings.
Undo	Returns all settings to the last saved state.
Refresh	Used on Testing and Monitoring screens to update statistics, and on other screens to redraw the screen.
Copy	Copies settings to next available slot
Netstat	Displays the Network Statistics Screen. See below.
Main	Returns to the CPU card main screen. If changes are made to settings and not saved, you will be prompted to save or lose changes.

Table 7-16. nX64 Screen Options and Defaults

Parameter	User Options	Default
STATE	actv stdby	stdby
WAN/SERV	none wan (w1-1, w1-2, w2-1, w2-2, w3-1, w3-2, w4-1, w4-2)	none
TS	n/a 1-24(T1) 1-31(E1)	no
FORMAT	hdlc fr ether	hdlc
RATE	56k 64k	64k
MTU	<128 - 1500>	240

STATE

The state indicates whether the port is enabled or disabled. Upon activation all parameters are validated. The selected IP address and netmask must be valid. The WAN must be available, and the selected combination of time slots must be available to activate the port. Default state is **stdby**.

WAN

This parameter indicates which WAN/SERV the nX64 can be connected to. The WAN selected should be available. If the selected WAN is removed and deleted, the port should be set to **stdby**. Default WAN is none.

TS

This table shows 24 selectable time slots when configured for T1, 31 selectable time slots when configured for E1. Time slot 16 is only available if TS16 is set to **nos** from the WAN screen. No time slots are selected as default.

FORMAT

The format indicates which format is selected for the given nX64 communications port. Possible options are HDLC, Frame Relay and Ethernet. Ethernet is only allowed for communications port1. Default setting is HDLC.

RATE

The Rate setting allows you to adjust the speed of the circuit according to the application requirements. The only speed available for ports C1 to C4 is **64k** (64 kbps). However, ports 1 to 64 can be set to either **56k** or **64k**.

MTU

The MTU needs to be 240 for 1x64 in order to communicate with the MCC. Since the MTU is desired larger than that this needs to be a configurable option. Dependent on implementation this can either be a number entered in a given range, or the selection from a predefined list of fixed MTU sizes.

7.5.2 Network Statistics Screen

Figure 7-24 shows the Netstat screen for the network statistics at the interface level for the selected nX64 communications port. The IP stack netstat is available from the standard CPU IP screen.



Figure 7-24.nX64 Netstat Screen

Table 7-17. nx64 Netstat Screen Actions

Action	Function
Refresh	Used on Testing and Monitoring screens to update statistics, and on other screens to redraw the screen.
Main	Returns to the CPU card main screen. If changes are made to settings and not saved, you will be prompted to save or lose changes.

7.6 CPU Host Software Upgrade Procedure

This section provides procedures for upgrading Integrated Access System host software.

The CPU-7 XCON card (880770) contains the host software that controls the Integrated Access System. The host software is stored in flash memory facilitating download of future software releases to the CPU card.

7.6.1 Equipment Requirements

Following are the equipment requirements for CPU host software upgrade.

- CPU-7 CPU XCON's with Ethernet port equipped with 7.0.0 or greater host software
- Laptop computer running Windows OS
- Serial port cable to connect to the TERM port on the Integrated Access System
- Interface card, one of: 893270, 893370 or 893470

7.6.2 Laptop Setup

Follow the steps listed below to set up the laptop computer.

1. Boot the laptop.
2. Click "**START**".
3. Select "**Programs**", "**Accessories**", and click on "**HyperTerminal**".



Note: *DO NOT USE ProComm Plus to backup the channel bank configuration. The use of ProComm will result in the corruption of all configuration data and will require that the channel bank configuration to be restored to factory defaults and re-configured.*

4. In the HyperTerminal window, double click on "**Hyperterm**" icon.
5. In the *New Connection* window, *Enter Name:* enter **Upgrade**.
6. Select icon and click **OK**.
7. In *Connect to Window*, *Connect Using*, click down arrow and select "**Direct to COM1**".
8. Click **OK**.
9. In COM 1 window, set BITS per second to "**9600**" (leave other settings as is) click **OK**.

10. In Upgrade window, click **File** menu, select **Properties**, and select **Settings**.
11. In Emulation window, select **VT100** and click **Terminal Setup**.
12. Select **132 column mode**, click **OK**.
13. Close **Properties** window and save.
14. Right click on **Upgrade Icon** and select **Create Shortcut**.
15. Drag shortcut to the desktop.

7.6.2.1 Log Upgrade Activity

Create a log to record upgrade activity on a per-site basis that includes the following information:

- Site name, date and time, and name of technician performing upgrade
- System name(s) and number of CPU cards per system
- Model, serial number, and host version of previous CPU cards
- Model, serial number, and host version of new CPU cards
- Model and serial number of Interface card

7.7 Upgrades

7.7.1 Upgrades Preparation

An upgrade takes the IMACS through a change in the operating software. Any change forward has been tested, but could still result in an error. As part of the preparation for an upgrade, making a copy of the existing, working configuration is of vital importance. Routine maintenance would suggest making regular copies of the database, but this is especially true prior to upgrading the shelf to a new level of software. With the upgrade also introduces during the upgrade a risk of downgrades. Although care is taken to ensure that a downgrade of the software (going to a software release number lower than what is currently running) does not cause issues, this action is the one that has the most potential for incompatibility.

1. Connect the PC or laptop to the TERM port on the Interface card of the IMACS chassis via a straight-through Ethernet cable.
2. Press **enter** and log into the system.
3. Make a copy of the database. if you are unfamiliar with this process, refer to Section 5.12.5 on page 5-48

4. When making a database, choosing the xmodem or tftp options will automatically write the a copy of the running configuration to flash on the CPU card. This should be done from both processors, so each will have a backup and on-board copy of the running configuration. However, it should be noted both the tftp and xmodem copies of the database are in binary format. Highly useful is an ASCII copy of the database which can be examined for provisioning entries.

7.7.2 Software Download Procedures

Upgrading the system software is done in two steps. First, get the new software loaded onto the inactive bank of the card. Secondly, update the running system software. First we will cover the transfer agents used to deliver software to the IMACS shelf, either **xmodem** or **tftp**.

7.7.2.1 High-level upgrade overview:

1. "Load the inactive processor bank with software release 7.x.y
2. "Use the **actvsw** command to activate the software bank and switch the processors.
3. "Once the system restores, load the inactive processor bank with software release 7.x.y.
4. "Use the **actvsw** command to activate the software bank and switch the processors.
5. "After the system recovers, load the inactive flash bank with software release 7.x.y
6. "Use the **actvsw** command to activate the software bank and switch the processors.
7. "Once the system recovers, load the inactive flash bank with software release 7.x.y.

7.7.3 Detailed upgrade procedure:

7.7.3.1 XMODEM Protocol Binary Download

Follow the steps listed below to perform an XMODEM protocol bin download.

1. Set up a direct connection to the VT-100 craft port.
2. Locally connect the PC to the VT-100 craft port. Log into the system with the *Superuser* password.
3. Highlight the active CPU and press "**P**".
4. The binary buffer area appears, and one of the buffers displays in an active state. The other buffer may be empty or may have a file in it. The kernel version on the lower half of this screen indicates *7.0.0* with a *checksum* of 0x12A754.

5. If both buffers have files in them, highlight the buffer that is not active. Press the **Enter** key and three options appear at the bottom of the screen. Using the arrow keys, highlight the *dnload* (download) parameter and press **Enter**. The CPU will automatically erase the existing load. Two parameters will appear at the bottom of the screen.
6. Using the arrow keys, select the *XMODEM* parameter and press **Enter**. The letter “C” will begin duplicating across the screen. This is normal and does not indicate a problem.
7. At the HyperTerminal screen, select *file transfer* and send the file. Choose the appropriate binary file to download using the *XMODEM* protocol to BIN buffer 1 or 2, depending upon which bin is empty. The binary file being downloaded **must** match the BIN number into which it is loading, and the binary file will be marked with either a 1 or a 2 accordingly.
8. Once the inactive bin has completed loading, the system will automatically check that it has loaded properly. If a *checksum mismatch* message appears, then the bank must be loaded again. Once the bank is loaded and passes checksum validation, it will be marked as “full”.
9. Press carriage return on top of the *full* status. Three options appear. If this is a simplex (single-processor) system, then select **actv**. **NOTE:** Choosing to **actv** a load on the same card that is currently carrying the system traffic will cause a restart of the system. For a duplex (dual-processor) system, the **actsw** will appear and should be used. The **actsw** command results in minimum traffic impact on the supported card list. For either the **actv** or **actsw** command, confirm the request to switch.
10. For a simplex system, load the inactive processor and the upgrade is complete. For a duplex system, repeat steps 5, 6 and 7 to load the new software into the ‘full’ bank.
11. Once the bank has loaded and the checksum has passed, once again press carriage return and choose the **actsw** command. Confirm the switch.
12. On the newly active card, load the inactive processor bank. This will complete the upgrade on this card.
13. Arrow to the “full” bank from step 12 above, and once again choose **actsw** to make this bank active and switch to the other card.
14. On the newly active card, load the inactive processor bank. This completes the software upgrade on this node.
15. Be sure to save a database backup in order to preserve the system settings.

7.7.3.2 Pre-TFTP Binary Upload/Download Preparation

To perform binary (bin) uploads/downloads via the TFTP function, one of the following three methods of connection to a Local Area Network (LAN) network must first be selected.

1. The first and preferred option is through the Ethernet port on the CPU card.
2. The second option requires that the system to which you will download be powered and running through an active MCC server card that is connected to a LAN. The connection must be made either in the box that will receive the downloaded file or in a remote box routed through the local CPU that is set as a gateway using an IP protocol. You must be able to ping the MCC card and the local and remote CPU host IP addresses from the PC or server that you intend to use as a TFTP server and vice versa. The DEF RTE on the MCC Ethernet configuration screen must be set to *static* and must include the IP address of the PC or server from which you are downloading the firmware. You may need to change the routing table on your PC to include the MCC ethernet address as the gateway, or the local host address as the gateway for the system receiving the file as the destination IP address.
3. The third option is to connect to the Integrated Access System interface card's COM (C1) port to which you will download the firmware using PPP or SLIP protocol at 19.2k or 9.6k respectively. Again, you may need to change the routing table on your PC and/or on the router or terminal server through which the PPP/SLIP connection runs.



Note: *Your PC must have some sort of TFTP server software installed and running when you are downloading the binary files to the system. Consult the user guide accompanying the TFTP software for details on configuring and using the software.*

7.7.3.3 TFTP Protocol Bin Download

Follow the steps listed below to perform a TFTP protocol bin download.

1. Establish connection in one of the following methods:
 - Telnet directly to the CPU ethernet port
 - Telnet connection to the Integrated Access System, using the SLIP/PPP connection via the computer port (COM1) connected through a terminal server or router.
 - Telnet connection through the MCC card, via HDLC or B7R / B4R.
2. Log into the Integrated Access System using an administrator password.
3. Highlight the appropriate CPU with the cursor and press “P”.
4. The binary buffer area appears, and one of the buffers will display an active state. The other buffer may be empty or may have a file in it. The lower portion of this screen shows the current kernel version, and should indicate *7.0.0* with a *checksum* of 0x12A754.

```

Flash Screen | C1 CPU XCON Rev D2-0 Ser 00031 | 02-27-14 15:11
BLOCK NUMBER:      1                2
STATUS             full              actv
MODEL              CPU XCON          CPU XCON
VERSION            7.2.3             7.2.4
I.D.               1                 2
CHKSUM             0x7E4C748         0x7EF55A5

Kernel 7.0.0, Checksum 0x12A754

Copy | Refresh | Main

```

Figure 7-25. CPU Programming level

5. If both buffers have files in them, highlight the buffer that is not active. Press the **Enter** key and three options appear at the bottom of the screen.
6. Using the arrow keys, highlight the *dnload* (download) parameter and press **Enter**. The CPU will automatically erase the existing load. Two parameters will appear at the bottom of the screen.
7. Highlight the *TFTP* parameter and press **Enter**.
8. A *mismatch retries* entry appears. Press **Enter** to invoke the default.
9. A *time-out retries* entry appears. Press **Enter** again to invoke the default.
10. An *IP address* option parameter appears. Enter the appropriate IP address of the PC or the TFTP server into this field and press **Enter**.
11. At this point a *file* parameter appears, prompting for the name of the file being downloaded to the system. Enter the file name as shown when scanning directories using the C:\DIR/W command and press **Enter**. If using Windows Explorer the file may be truncated and the system will not be able to find the file.

If the download process is successful, a decreasing number of bytes begins to appear on the screen. If something has been configured incorrectly, data will not be sent and following expiration of the time-outs an error message appears.

12. Press carriage return on top of the *full* status. Three options appear. If this is a simplex (single-processor) system, then select **actv**. **NOTE:** Choosing to **actv** a load on the same card that is currently carrying the system traffic will cause a restart of the system. For a

duplex (dual-processor) system, the **actsw** will appear and should be used. The **actsw** command results in minimum traffic impact on the supported card list. For either the **actv** or **actsw** command, confirm the request to switch.

13. For a simplex system, load the inactive processor and the upgrade is complete. For a duplex system, repeat steps 5 through 11 to load the new software into the 'full' bank.
14. Once the bank has loaded and the checksum has passed, once again press carriage return and choose the **actsw** command. Confirm the switch.
15. On the newly active card, load the inactive processor bank. This will complete the upgrade on this card.
16. Arrow to the "full" bank, and once again choose **actsw** to make this bank active and switch to the other card.
17. On the newly active card, load the inactive processor bank. This completes the software upgrade on this node.
18. Be sure to save a database backup in order to preserve the system settings.

7.8 CPU Card Error Messages

Refer to Appendix B in the System Reference Guide for further information on Error Messages regarding this card.

7.9 CPU Card Troubleshooting

On power-up, the CPU card performs a self-test. This is the only diagnostic available for the CPU. A “healthy” active CPU will have a green LED lit on the front panel. A “healthy” redundant CPU will flash between green and amber LEDs.

The indications that a CPU is not on-line are:

- Continuous amber alarm LED on front panel AFTER the system has been registered during initial installation. Prior to registration, the amber LED is an indication that registration needs to occur before the system can be fully operational.
- Inability to communicate with the system by any means (VT-100 Term, Telnet, etc.).

Because the CPU and Interface card work together to support a system, follow this general sequence:

1. Verify that the CPU card's US/EUR jumper (HD1) is correctly set to match the US/EUR jumper on the chassis.
2. Verify that both CPUs in a redundant system are of the same firmware revision.
3. First replace the CPU. If the problem continues, replace the Interface Card.



Note: *Removal of an active CPU or Interface card will cause a service disruption on the entire system.*

4. If the CPU card is determined to be faulty, replace it and return the faulty unit for repair to the location specified by your distributor.

7.10 CPU Card Specifications

CPU Card 880770 with 10baseT Ethernet port.		
LED Indicators		
Operation	Green for normal operation. Yellow for card fault or test mode (amber on Model 880770).	
Code storage		
Model 880770	Configurable with maximum 8 MB DRAM and 4 MB Flash Memory	
Operational Modes		
Model	Mode	Cross Connect
880770	cross-connect	yes
Maximum number of WAN links		
Model 880770	Up to 8 WAN links	
Support for CPU redundancy		
Model 880770	yes	
Support for WAN link redundancy		
Model 880770	1:N. A single model 8014 WAN card in slot W4 can provide back-up for identically configured 8010 WANs in slots W1 through W3.	
Support for Resource/Server Cards		
Model 880770	Support for all server cards	
Standards Compatibility		
Bellcore	GR-63-CORE Issue 1	Network Equipment-Building System (NEBS) Requirements: Physical Protections
CEN	EN 50 081-1	Electromagnetic compatibility generic emission standard Part 1 Residential, commercial and light industry
	EN 50 082-1	Electromagnetic compatibility generic immunity standard Part 1 Residential, commercial and light industry
	EN 60 950/A2	Safety of information technology equipment including electrical business equipment
UL	1950	UL Standard for Safety of Information Technology Equipment
CSA	C22.2, No. 950	Safety of information technology equipment including electrical business equipment
IETF	RFC 1769	Simple Network Time Protocol (SNTP)",
	RFC 2865	Remote Authentication Dial In User Service (RADIUS).
	RFC 2882	Extended RADIUS Practices
	RFC 5424	The Syslog Protocol
IEEE	802.3i	10BASE-T 10 Mbit/s (1.25 MB/s) over twisted pair.
	802.3u	100BASE-TX, 100BASE-T4, 100BASE-FX Fast Ethernet at 100 Mbit/s (12.5 MB/s) w/auto negotiation

Chapter 8

Interface Card

8.1 Introduction

This chapter provides specific installation, configuration, and troubleshooting information for the Interface Cards of the Integrated Access System. These cards are labeled as the INTF-R EXT T1E1*8, INTF-R MODEM T1E1*8, and INTF-R T1E1*8 cards, respectively, on their faceplate ejectors. Each card provides communications connections to the system for operator access and system control. Throughout this chapter, these cards are referred to as the INF-R Ext, INF-R Modem, and INF-R cards.

The Interface cards for CPU-7 use have been modified to eliminate a possible source for operational interruptions. The cards have been sectioned into two pieces: the bottom section, referred to as the motherboard, and the top portion referred to as the daughter board.

All active components have been removed from the motherboard, to allow for a virtually failure-proof avenue for the incoming T1 or E1 signals to pass from the faceplate to the backplane. This design allows for a secure, reliable path that should never need be removed or interrupted from providing external connectivity to the IMACS shelf.

The daughter board has been populated with all of the active components, and should one of these active components fail, the craftsperson can simply remove and replace the daughter board without causing an interruption to the system.

8.2 Interface Card Descriptions

8.2.1 INTF-R Ext Card Description (893270)

The INTF-R Ext card provides the communications, control, and network interface ports. It has an RJ48 jack for network management; this port is configured as DTE. It also has a RJ48 jack that connects it to the node port for alarm notification, and a local VT-100 terminal port. An RJ48 external sync port allows clocking from external primary and secondary clock sources. The INTF-R Ext card supports up to eight T1 or E1 WAN links (see Figure 8-1).

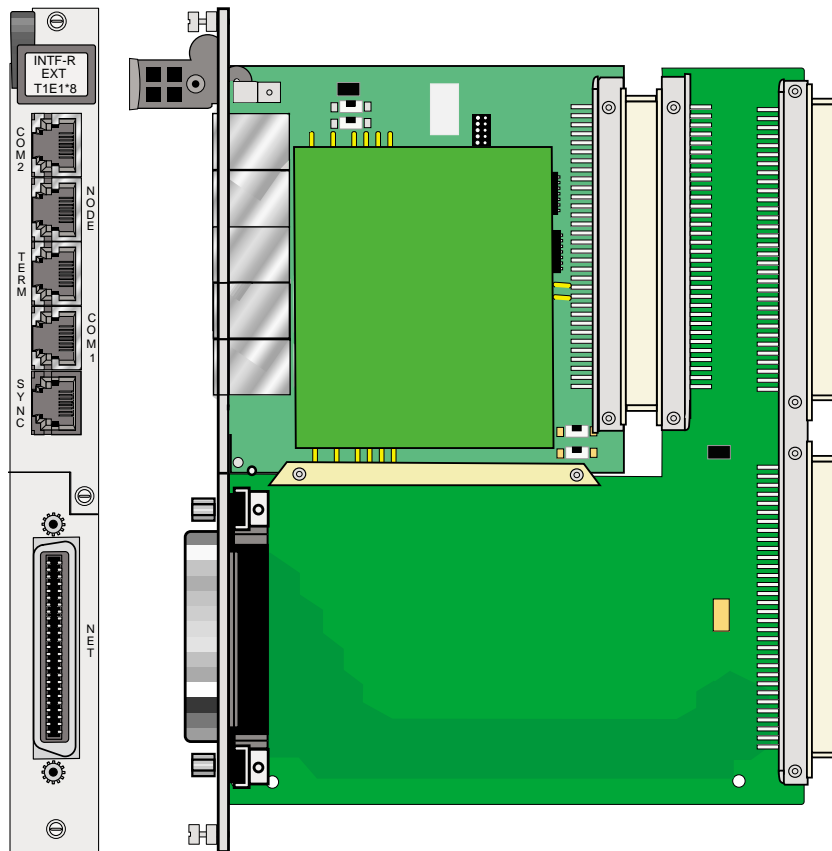

Figure 8-1. INTF-R Ext Interface Card (893270)

8.2.1.1 Card Jumper/Switch Settings

The INTF-R Ext card doesn't have any jumpers or switches on its mainboard.

8.2.1.2 Installing the INTF-R Ext Card

Install the INTF-R Ext card into the IF slot of the system chassis. Each system can have only one INTF-R Ext card.

8.2.1.3 External Sync daughter card

The External Timing Sync card is used to provide a means of terminating external clocking source inputs into the faceplate of the INTF-R Ext board. (see Figure 8-2 for jumper arrangements diagram and Table 8-1 for jumper settings).

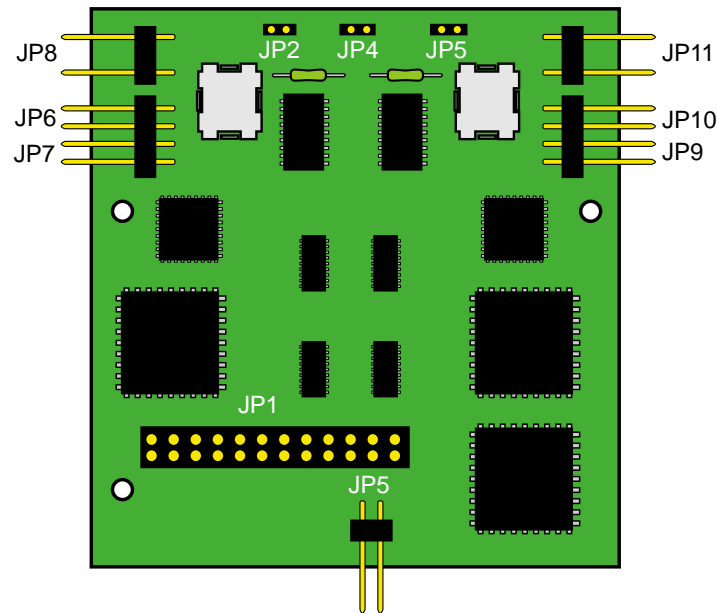

Figure 8-2. Jumper Arrangements for the T1/E1 External Sync Card

Table 8-1. Jumper Settings for the T1/E1 External Sync Card

Jumper #	Position	Results
JP5	Open	T1
JP5	Closed	E1
JP8 and JP11	Open	Balanced
JP8 and JP11	Closed	Unbalanced
JP6 and 7	Open	Ext1 (T1) 100 Ohms
JP9 and 10	Open	Ext2 (T1) 100 Ohms
JP6 and 7	Closed	Ext1 (E1) 75 Ohms
JP9 and 10	Closed	Ext2 (E1) 75 Ohms

8.2.1.4 Equipment Grounding Requirements

When connecting cables from other AC-powered equipment (such as computer terminals) to the Interface card, **make sure the other equipment is properly grounded**. Ground connections are normally provided by the ground (third) prong of an AC plug. Some PCs, especially portables and laptops, have power supplies with two-pronged plugs; they are not properly grounded.

When a cable is run from a PC that is not properly grounded to the Interface port of the system, a high voltage differential (up to 100 VAC) may result between the system and the PC. This can severely damage the Interface card, PC, or both.

As a rule, all cards with data interface connectors (RS-232, RS-422, RS-530, etc.) could be damaged if connected to poorly grounded equipment. **All persons authorized to use or service the Integrated Access System should be familiar with good grounding practices.**

8.2.2 INTF-R Modem Card Description (893370)

The INTF-R Modem card has an internal modem that allows remote operator to communicate with the system. However, it does not accept external synchronization clocks. In all other respects, the INTF-R Modem card is functionally identical to the INTF-R Ext card (see Figure 8-3).

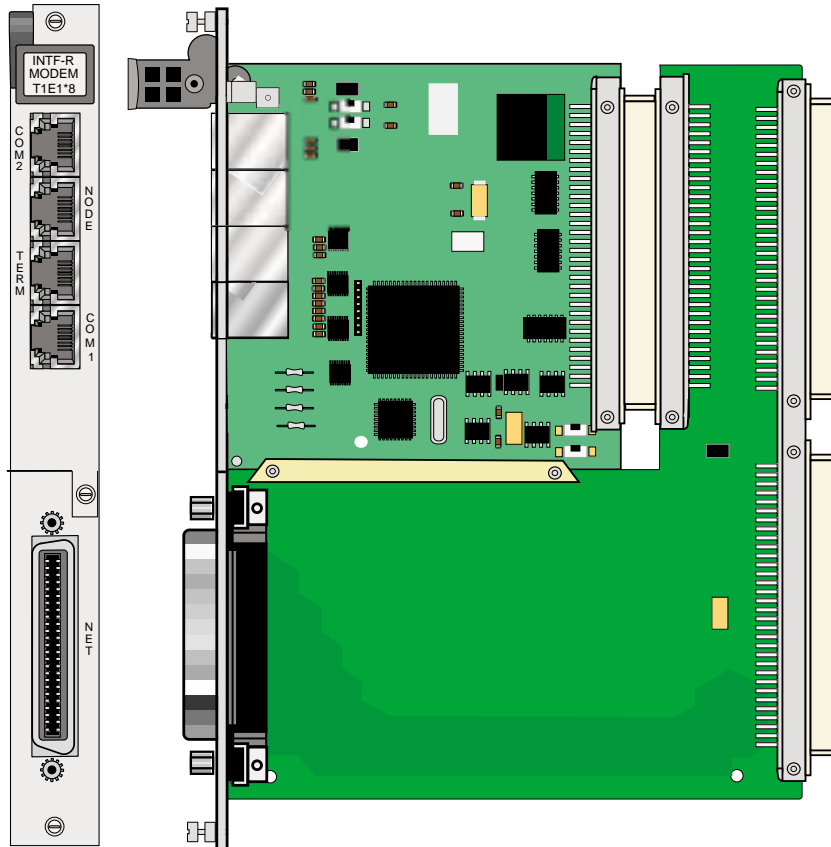

Figure 8-3. INTF-R Modem Interface Card (893370)

8.2.2.1 Card Jumper/Switch Settings

The INTF-R Modem card doesn't have any jumpers or switches on its mainboard.

8.2.2.2 Installing the INTF-R Modem Card

Install the INTF-R Modem card into the IF slot of the system chassis. Each system can have only one INTF-R Modem card.

8.2.3 INTF-R Card Description (893470)

The INTF-R card does not have a modem and does not accept external synchronization clocks. In all other respects, it is functionally identical to the INTF-R Ext and INTF-R Modem cards (see Figure 8-4).

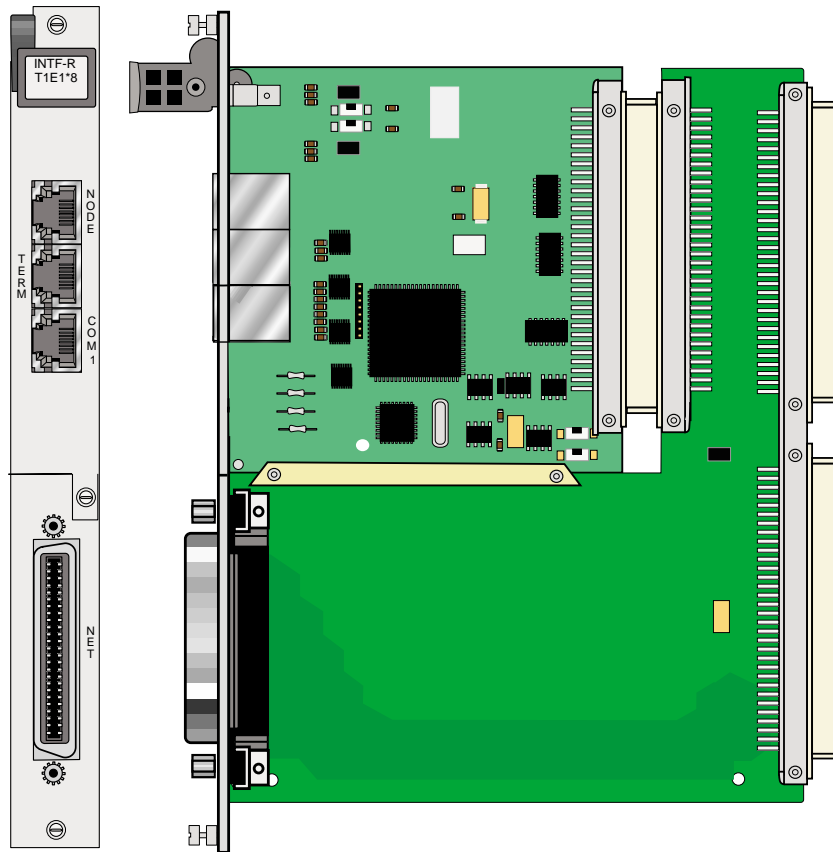

Figure 8-4. INTF-R Interface Card (893470)

8.2.3.1 Card Jumper/Switch Settings

The INTF-R card doesn't have any jumpers or switches on its mainboard.

8.2.3.2 Installing the INTF-R Card

Install the INTF-R card into the IF slot of the system chassis. Each system can have only one INTF-R card.

8.3 Interface Card User Screens and Settings

8.3.1 Interface Card Main Screen

Figure 8-5 shows the Interface Card Main Screen. You must use this screen to define two timing sources for the card, and then go to other screens for additional setup and information viewing instructions. To go to the Interface Card Main Screen, highlight that card in the System Main Screen and press <Enter>.

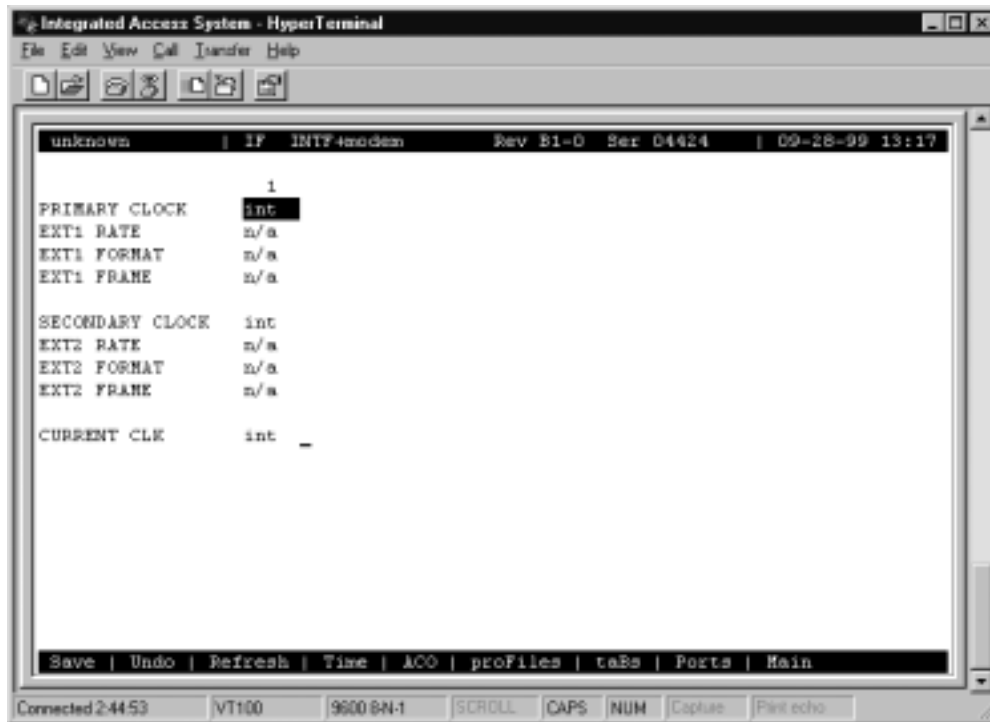

Figure 8-5. Typical Interface Card Main Screen

The bottom line of this screen shows numerous actions that you can perform from the screen. To perform an action, simply press the associated capital letter on your keyboard. For example, to save your option settings, press “s” (for **Save**). Table 8-2 lists the available actions.

Table 8-2. Interface Card Main Screen Actions

Action	Function
Save	Saves changes to settings.
Undo	Returns all settings to the last saved state.
Refresh	Used to redraw the screen.
Time	Sets the system time and date. See the "Setting the System Date and Time" section later in this chapter.
ACO	Turns ACO alarm on and off.
proFiles	Profiles function inoperable with this release.
taBs	Signaling conversion tables for ABCD bits from ANSI to ITU-T for voice circuits.
Ports	Allows you to configure each Interface card port for operation. See the "Ports Screen" section later in this chapter.
Main	Returns to the Main screen. If changes are made to settings and not saved, you will be prompted to save or lose changes.

8.3.1.1 Setting the System Date and Time

New in CPU-7 is the ability to time off the network via an SNTP server. This option is normally disabled, and is accessed via the normal method of setting the time on the shelf. Go to the Interface card screen, and then select "T" for time. The SNTP screen comes up as shown in the composite image below and the customer can choose to use this as the timing option or select "set Time" from this window to set the time in the traditional manner. Choosing the SNTP option allows the IMACS shelf to maintain the time of day clock in configurable time intervals. Using the traditional time of day methods would leave the IMACS to keep the time of day based on its own system clock, which would eventually lead to a time of day difference between the system time of day and the real time of day. Choosing the SNTP option allows the system to track it's time of day clock to an external source, leading to a much improved reflection of the system time of day and the actual time of day. This offering of an SNTP server is based off of version four (v.4) of the SNTP protocol.

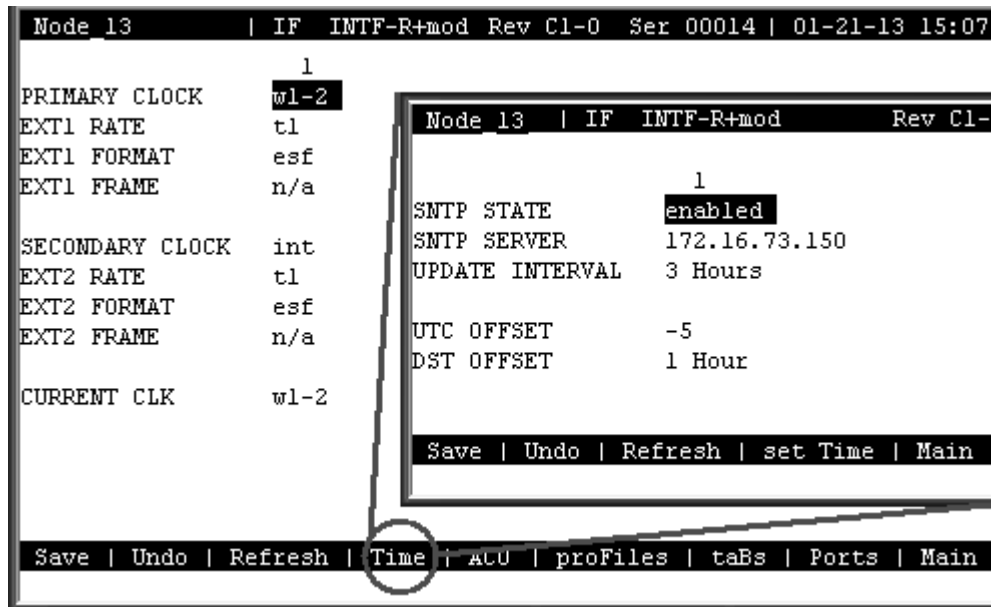

Figure 8-6. SNTP time server enabled

The default for the SNTP server is disabled. If the customer chooses to use the SNTP feature, then the state should be changed to enable and a server address input in the SNTP SERVER field to indicate the source of the timing stream. The update interval must also be set to indicate how often the IMACS should synchronize to the timing source. This field can be set to adjust the timing any of 1, 3, 6, 12 and 24 hours. The UTC offset also should be set to indicate the time offset from Greenwich Mean Time - anywhere from +13 to -12 hours. The final field to be set is the DST offset, which is used to either disable Daylight Savings Time, or alter it by an increment of 30 minutes, or one hour to two hours.

To set the current date and time for the Integrated Access System and allow the system to track on its internal clock, press “t” in the SNTP Main Screen to choose the **Time** action from the bottom line of that screen. The current date and time now appear in the lower left of the screen, in the format MM-DD-YY HH-MM. The **MM** field (month) is highlighted.

Use the up-arrow and down-arrow keys to set the current month (**01** to **12**, as required). Also move to each remaining field with the right-arrow and left-arrow keys, and select the current day (**DD**) and year (**YY**), and the current hour (**HH**) and minute (**MM**). The current time of day is displayed in 24-hour continuous format, where HH is **00** to **11** for a.m. and **12** to **23** for p.m.

When you finish setting these fields, press <Enter> and then press “y” to confirm that you want to save the changes. The system will subsequently stamp the current date and time on all alarm messages it reports.

8.3.1.2 Selecting the System Timing Clocks

Table 8-3 lists the Interface Card Main Screen configuration options, along with the possible and default values. In this screen, you must specify a primary and secondary timing source (clock) for the Integrated Access System. These settings are described in the following paragraphs.

Table 8-3. Interface Card Setting Options and Defaults

Parameter	User Options	Default
PRIMARY CLOCK	int serv(P1, P2, P3) wan(w1-1, w1-2, w2-1, w2-2, w3-1, w3-2, w4-1, w4-2) user(U1, U2, U3, U4, U5, U6, U7, U8)	int
EXT RATE	n/a	n/a
EXT FORMAT	n/a	n/a
EXT FRAME	n/a	n/a
SECONDARY CLK	int serv(P1, P2, P3) wan(w1-1, w1-2, w2-1, w2-2, w3-1, w3-2, w4-1, w4-2) user(U1, U2, U3, U4, U5, U6, U7, U8)	int
EXT RATE	n/a	n/a
EXT FORMAT	n/a	n/a
EXT FRAME	n/a	n/a
CURRENT CLK	cannot edit this field	---

PRIMARY CLOCK

The primary clock provides all internal timing for the system. You can select a network clock source or the system's internal crystal oscillator.

A network clock is the best Primary Clock source. To select this source, set the Primary Clock field to **wan**, and then specify the WAN link to which the clock source is connected (for example, **w1-1** for T1 or E1 link 1 on the WAN card in chassis slot W1). The WAN clock source will be either 1.544 or 2.048 Mbps (T1 or E1 link). This clock must be accurate to within ± 50 parts per million (50×10^{-6}).

Select **int** to have the system generate a clock from its own internal crystal oscillator. The stability of this Stratum 4 clock is ± 25 parts per million (25×10^{-6}). If you use the system's internal crystal oscillator as a clock source, all other devices attached to the network should also derive their timing from it.

Select **serv** to use a primary clock derived from an ATM server card in the system. If you choose this setting, also specify the associated card slot (**P1, P2, or P3**). If you select a slot that contains any other type of server card, the message **CARD CANNOT BE SELECTED** appears.

Select **user** for a primary clock from a BRI card in the system. If you select **user**, also specify the chassis slot location of the desired card (**U1 to U8**), followed by the card port from which the clock will be provided (**u1-1 through u8-8**) as required. If you select a chassis slot that contains any other type of user card, the message **CARD CANNOT BE SELECTED** appears.

If your system has an INF-E card, AND if external synchronization clocks are connected to its SYNC jack, select either **ext1** or **ext2**. The options **ext1** and **ext2** are used when the primary clock is derived from an external timing source.

Refer to **EXT FORMAT** below for more information on external source clocking.

EXT RATE

Set this option for the primary clock to **t1** for a 1.544 Mbps WAN clock, or to **e1** for a 2.048 Mbps WAN clock. If all WAN links in a system are either T1 or E1, this option should automatically default to the correct rate.

EXT FORMAT

If EXT RATE is **t1**, set this option to **esf** or **d4**, as required by the T1 link. This option does not appear if the Line Rate is **e1**.

EXT FRAME

If EXT RATE is **e1**, set this option to **crf** or **d-frm**, as required by the E1 link. This option does not appear if the Line Rate is **t1**.

SECONDARY CLOCK

If the Primary Clock signal fails, the system automatically switches to an operator-defined Secondary Clock source. In the event of a failure to the Primary Clock Source, once it is fixed it will automatically restart. The secondary clock source may be a different WAN link, server, user card, or external source, or it can be the system's internal crystal oscillator. Although a secondary clock source is not required for system operation, you should always provide one for the system.

EXT RATE

Set this option for the primary clock to **t1** for a 1.544 Mbps WAN clock, or to **e1** for a 2.048 Mbps WAN clock. If all WAN links in a system are either T1 or E1, this option should automatically default to the correct rate.

EXT FORMAT

If EXT RATE is **t1**, set this option to **esf** or **d4**, as required by the T1 link. This option does not appear if the Line Rate is **e1**.

EXT FRAME

If EXT RATE is **e1**, set this option to **erc** or **d-frm**, as required by the E1 link. This option does not appear if the Line Rate is **t1**.

CURRENT CLK

The Current Clock field shows the primary or secondary clock now in operation. You cannot edit this field.



Note: Jumper positions will affect the available choices.

8.3.2 Call Profile Screen

To enter a new call profile, first press “F” in the Interface Card Main Screen (**proFiles** command). Then, type **01** for the first new profile to be created. This brings up the Call Profile Screen shown in Figure 8-7.

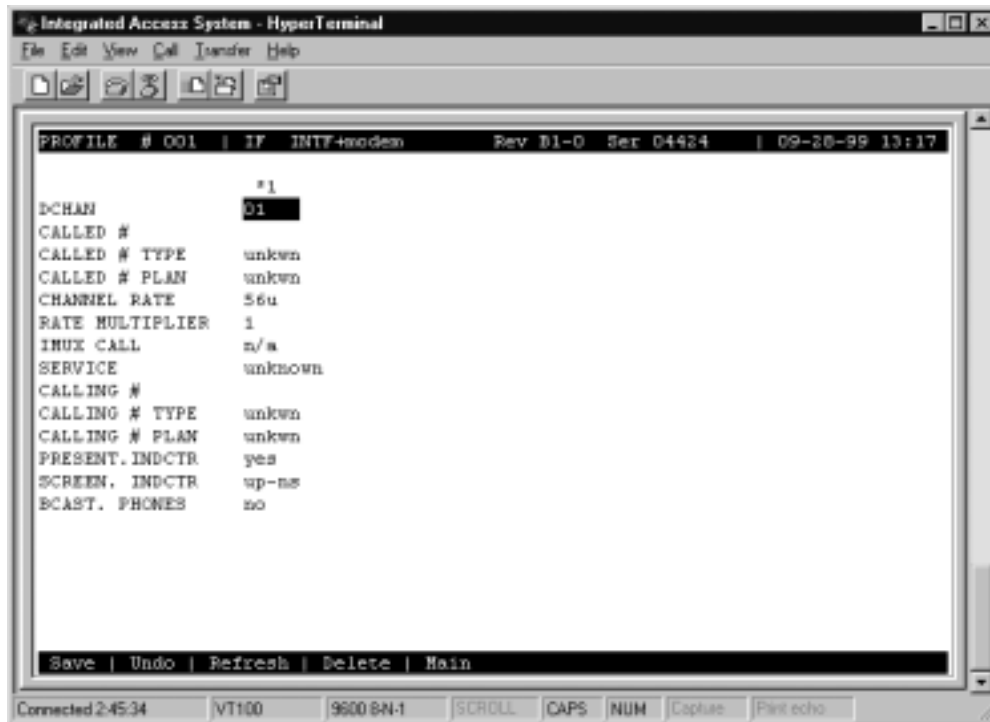

Figure 8-7. Typical Call Profile Screen

In the current system software version, you can program up to six call profiles.

Since leading zeros are ignored, the entries **001**, **01**, and **1** all refer to the same call profile. If the call profile does not already exist, the system will ask if you want to create it now.

Table 8-4 lists the actions you can perform from the Call Profile Screen. Table 8-5 shows the settings and defaults for each parameter.

Table 8-4. Call Profile Screen Actions

Action	Function
Save	Saves changes to settings.
Undo	Returns all settings to the last saved state.
Refresh	Used to redraw the screen.
Delete	Deletes the call profile on the screen. You are prompted with yes/no question prior to deletion.
Main	Returns to the Interface Card Main Screen. If changes are made to settings and not saved, you will be prompted to save or lose changes.

Table 8-5. Call Profile Screen Options and Defaults

Parameter	User Options	Default
DCHAN	01-08	01
CALLED #	telephone number (25 numeric characters)	blank
CALLED # TYPE	natnl intl sbscr unkwn	unkwn
CALLED # PLAN	unkwn isdn phone print	
CHANNEL RATE	56u 56r 64u 64r 384u 384r 1536u 1536r MRate	56u
RATE MULTIPLIER	1, 6, 24, or 2 to 30	1
IMUX CALL	n/a	n/a
SERVICE	service from list set on ISDN card for this D channel (first 7 characters)	blank
CALLING #	telephone number (25 numeric characters)	blank
CALLING # TYPE	natnl intl sbscr unkwn	unkwn
CALLING # PLAN	unkwn isdn phone print	unkwn
PRESENT. INDCTR	yes no	yes
SCREEN. INDCTR	reserved for future use	up-ns
BCAST. PHONES	no yes	no

Notes:

1. The Rate Multiplier is as follows:

1 if the Channel Rate is **56u**, **56r**, **64u**, or **64r**.

6 if the Rate is **384u** or **384r**.

24 if the Rate is **1536u** or **1536r**.

From **2** to **30** if the Rate is **MRate**.

DCHAN

The D-Channel number identifies which D-channel to route all outgoing calls that use this call profile. The options are numbers **1** to **8**.

CALLED

The Called Number is the full telephone number of the device you are calling. Up to 25 numeric characters are allowed, although most calls use only ten digits. This parameter can be overridden on a call-by-call basis when RS-366 or V.25bis dialing is used with the 8213 HSU Card.

CALLED # TYPE

The Called Number Type identifies the type of network used to reach the called phone number. The options are **natnl** for domestic calls, **intl** for international calls, **sbscr** for Virtual Private Network (VPN) calls, and **unkwn** (default). Your carrier will provide more detail about this option.

CALLED # PLAN

The Called Number Plan refers to the type of numbering plan used to reach the device you are calling. The options are **unkwn**, **isdn**, **phone** and **privt**. Your carrier will provide more detail about this option.

CHANNEL RATE

The Channel Rate selection specifies the bandwidth to be used by the call. Different carriers support different rates, so it is important to check with your carrier before setting rates greater than 64 kbps. When using any Channel Rate other than **MRate**, the system knows the size of the bandwidth required and will automatically select the rate multiplier. If **MRate** is selected, the user must enter the rate multiplier.

The “**u**” and “**r**” in these selections identify unrestricted and restricted data calls. An **unrestricted** call means that you can send any type of data information in the circuit. A **restricted** call means that you must maintain the ones-density-integrity of the T1 data stream.



*Note: Channel Rates of **1536r** and **1536u** require the use of NFAS.*

RATE MULTIPLIER

The Rate Multiplier setting depends on the Channel Rate chosen in the previous paragraph. If the Channel Rate is set to **MRate**, the Rate Multiplier can be from **2** to **30**. If an incorrect rate multiplier is input, the carrier equipment will reject the call.

IMUX CALL

The IMUX Call field has no application on this screen and will always show as **n/a**. This field is only activated when downloaded to the HSU card and used to designate an IMUX call. For more information, please review the HSU card chapter.

SERVICE

The Service parameter is entered only if call-by-call service selection is supported on the D channel selected in the DCHAN parameter above. If call-by-call service selection is provisioned on the selected D channel, the user must enter a valid service code in this field. Valid service codes are those that were entered for this D channel in the Services subscreen of the D channel configuration screen.

To change this selection, highlight the selection with the cursor and press the “Enter” key. A list of all service options for this D channel will appear at the bottom of the screen. Move the cursor to the appropriate selection using the right and left arrow keys and press the “Enter” key again when the correct choice is highlighted.

CALLING

The Calling Number is the phone number of the calling party that is presented to the called party when the incoming call is delivered. This feature is known as Automatic Number Identification (ANI).

If you want the main (billing) number to be presented to the called party, this field must contain a number of up to 25 digits. If you want the specific phone number of the HSU port making the call to be presented, leave this field blank.

CALLING # TYPE

The Calling Number Type identifies the type of network used by the calling party. The options are **natnl** for domestic calls, **intl** for international calls, **sbsr** for Virtual Private Network (VPN) calls, and **unkwn** (default). Your carrier will provide more detail about this option.

CALLING # PLAN

The Calling Number Plan refers to the type of numbering plan used by the calling party. The options are **unkwn**, **isdn**, **phone** and **privt**. Your carrier will provide more detail about this option.

PRESENT. INDCTR

The Present Indicator field determines whether or not the calling number may be displayed to the called party. The options are **yes** and **no**.

SCREEN. INDCTR

The Screen Indicator field is reserved for future use.

BCAST. PHONES

The Broadcast Phones parameter works with the HSU Call Profile to provide simultaneous one-way calls.

8.3.3 Signaling Conversion Table Screen

Signaling conversion is required when cross-connecting a T1 (ANSI) voice circuit to E1 (ITU-T). This process translates the sequences of the ABCD signaling bits to allow proper signaling between the two carrier types.

You can set up signaling conversion for all types of voice circuits from the Signaling Conversion Table Screen, which is shown in Figure 8-80. To go to that screen, press “b” in the Interface Card Main Screen (taBs command).

You can accept the default bit pattern changes, or you can set a different ABCD signaling bit pattern and insert it in the table. Each voice circuit type is represented by two columns that correspond to ITU-T to ANSI conversion (C->A) and ANSI to ITU-T (A->C) conversion.

ABCD	E&M		FXS/FXSC		FXO/FXOC		PLAR	
	C->A	A->C	C->A	A->C	C->A	A->C	C->A	A->C
0000	0000	1101	0101	0101	0101	0101	1111	0101
0001	0000	1101	0101	0101	0101	0101	1111	0101
0010	0000	1101	0101	1101	0101	1101	1111	1101
0011	0000	1101	0101	1101	0101	1101	1111	1101
0100	0000	1101	0101	1101	0101	1101	1111	1101
0101	1111	1101	0000	1101	1111	1101	0000	1101
0110	0000	1101	0101	1101	0101	1101	1111	1101
0111	0000	1101	0101	1101	0101	1101	1111	1101
1000	0000	1101	0101	1101	0101	1101	1111	1101
1001	0000	1101	0101	0101	0101	1101	1111	1101
1010	0000	1101	0101	0101	0101	1101	1111	1101
1011	0000	1101	0101	1101	0101	1101	1111	1101
1100	0000	1101	0101	1101	0101	1101	1111	1101
1101	0000	0101	0101	0101	0101	1101	1111	1101
1110	0000	1101	0101	1101	0101	1101	1111	1101
1111	0000	0101	0101	0101	0101	1101	1111	1101

Enter conv. bits: 0000

Save | Undo | Refresh | Default | Main

Connected 2:46:34 VT100 9600 8N-1 SCROLL CAPS NUM Capture Print echo

Figure 8-8. Signaling Conversion Table Screen

For example, an E&M circuit in the “0101” state (shown in the far-left ABCD column of the screen) will send **0101** as the ABCD bits from the ITU-T end of the circuit. The ANSI end will receive and convert those bits to **1111**. In the opposite direction, the signaling bit sequence will be sent as **1111** from the ANSI end and converted to **0101** at the ITU-T end. However, you can manually override the received ABCD bit pattern at either end.

The E&M portion of the Signaling Conversion Table Screen is also used for FXSDN, FXODN, PLAR-D3, DPO, and DPT signaling. The FXS/FXSC portion is used for FXO-to-FXS signaling, and the FXO/FXOC portion is used for FXS-to-FXO signaling. The PLAR portion is used for PLAR-D4 to PLAR and MRD.

Table 8-6 lists the actions you can perform from the Signaling Conversion Table Screen. These actions appear in the bottom highlighted line of the screen.

Table 8-6. Signaling Conversion Table Screen Actions

Action	Function
Save	Saves changes to settings.
Undo	Returns all settings to the last saved state.
Refresh	Redraws the current screen.
Default	Returns column to default settings, one column at a time. You must save your changes after using this command.
Main	Returns to the Interface Card Main Screen. If changes are made to settings and not saved, your changes will be lost.

8.3.4 Remote IMACS Terminal System (RITS)

The Remote IMACS Terminal System (RITS) is a special application for users using microwave transmission. Using communication software, a user can log into a number of different systems from a single control station (PC, MAC, Sun, or HP Workstation) to download alarm information, change card settings, and perform maintenance.

Systems are connected from the Interface card's COM port to a wireless control network through the RS232 input on one of the four service channels on the wireless network. The Control Station (PC) is connected to pin #2 out and #3 in. Each of the integrated access controllers is connected to RS232 pin #2 in and pin #3 out.

The actual number of the systems that can be connected together is determined by the amount of different numbers that can fit in the "SYS PH#" field in the CPU submenu. The CPU submenu is accessed by selecting a CPU through the user interface and pressing the <ENTER> key.

8.3.4.1 Identification

Each system has a unique identification number on the integrated access controller network (phone number). The unique identification number is used to determine which Controller can be accessed remotely on a serial line. The identification number for each console needs to be entered in the "SYS PH#" field in the CPU submenu. No two systems can have the same number in the "SYS PH#" on the same network. If that field is the same on more than one integrated access controller, race conditions will occur. Therefore each console on a single network must have an individual number in the "SYS PH#" field.

The identification numbers for the integrated access controllers cannot be entered through a control station. This safeguard is provided to ensure a reliable connection between a control station and an integrated access controller. Attempts to change an identification number of a system remotely will be denied.

8.3.4.2 Network Priorities

All integrated access controllers on the wireless network have equal priorities. Because of this equality, no Controller can interrupt a remote session between another Controller and a control station. This is why the control station always initiates all communication on the RITS network.

8.3.4.3 Intra-Network Communications

Integrated access controllers cannot communicate with each other. Communication on the network is only between the control station and a single Controller. Since the communications on the network of integrated access controllers is always initiated by the control station, the Controller systems cannot communicate with each other. Figure 8-9 shows a diagram of three RITS units.

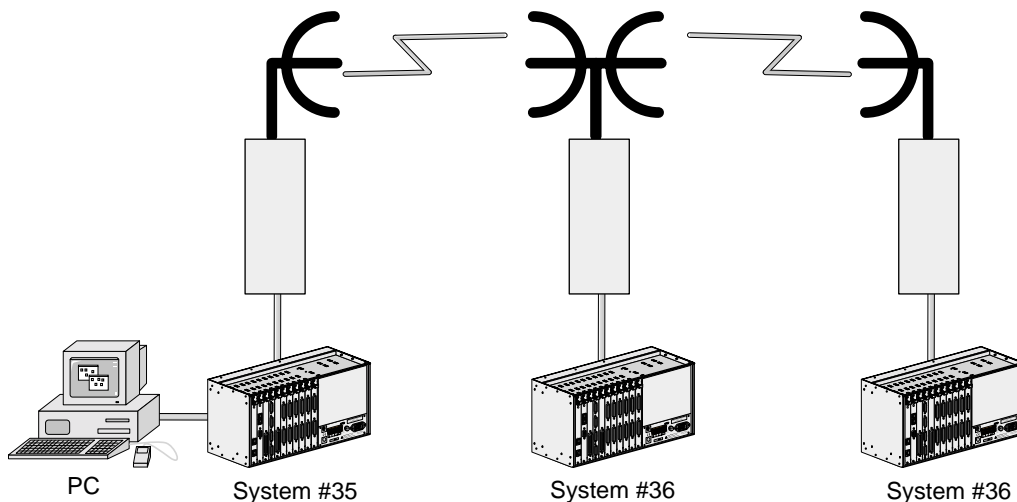

Figure 8-9. Typical RITS Configuration

The PC associated with integrated access controller #34 can engage any of the two other units by using “AT” commands from the communications software used. If a local VT-100 is active at any of the remote locations, the user will be logged off and the master PC will control the system unit. When the master PC logs off, the local user will be able to log into the unit again. Connections at all units are done through the DB9 computer port.

8.3.4.4 Terminal Security

No user may log into any integrated access controller on the network without knowing the individual password of each system.

Table 8-7 list the “AT” commands and the associated function. All “AT” commands are followed by pressing the <ENTER> key.

Table 8-7. “AT” Commands Used by RITS

AT Command	Function
ATDTxxx	Establish a user interface connection.
ATDTxxxR	Establish an alarm reporting connection. (Connection only lasts for the length of time necessary to upload and display all alarms that are being reported by the system that have not yet been displayed.)
ATDTxxxC	Establish a current alarm reporting connection. (Connection only lasts for the length of time necessary to upload and display all active alarms that are being reported by the system.)
ATDTxxxH	Establish a historical alarm reporting connection. (Connection only lasts for the length of time necessary to upload and display the alarm history reported by the system.)
ATDTxxxCH	Establish a current and historical alarm reporting connection. (Connection only lasts for the length of time necessary to upload and display the current alarms and alarm history reported by the system.)
+++	Disconnects a remote session.
“L” (letter L)	Disconnects a remote session.
xxx indicates the phone number on the CPU card of the desired system unit.	

8.3.5 Ports Screen

You also must configure each of the Interface card's user interface ports. This is done from the Ports Screen, which is shown in Figure 8-101. To go to this screen, press "p" in the Interface Card Main Screen (**P**orts command).

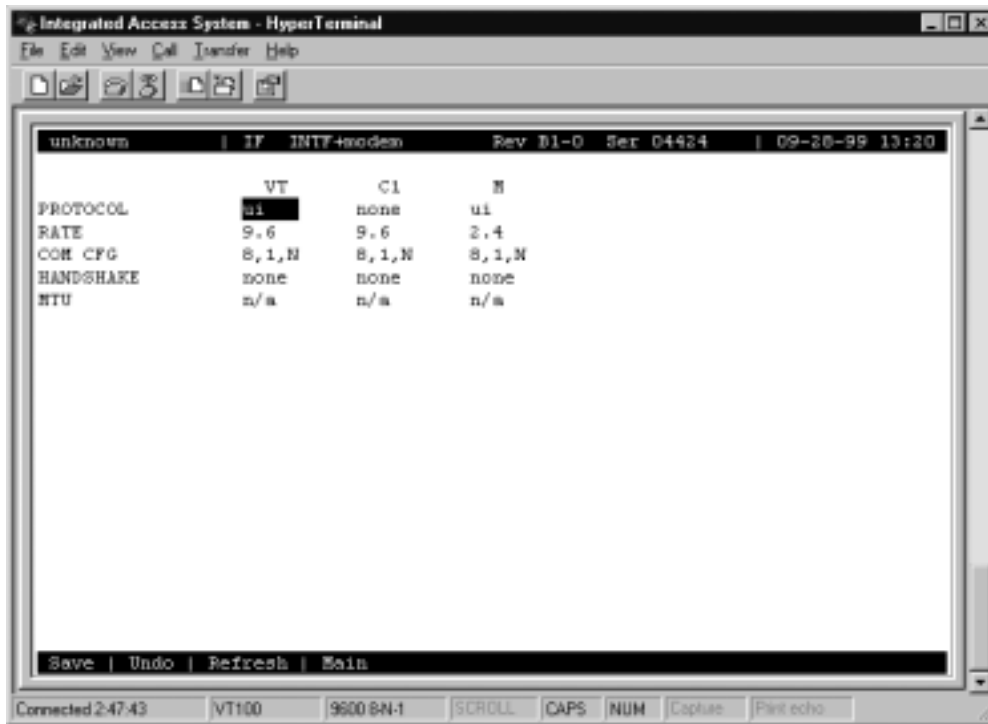

Figure 8-10. Typical Ports Screen (INTF+M)

This screen shows the Protocol, Rate, Communications, and Handshaking control settings for each port. The VT column lists the current settings for a VT100-compatible terminal connected to the TERM modular jack on the Interface card faceplate. The C1 column is for an external computer connection to the COMP (or COM1) DB-9 plug on the card. The M column is for a modem connection from an INF+M card to a remote facility via a phone line.

The screen settings are described in the following paragraphs.



Note: There are two scenarios in Figure 8-10. The Typical INTF+M Ports Screen shown above displays (VT - VT100 terminal, C1 - COM1, and M-Modem). However, if INTF+E is used the screen will display (VT, C1, and C2 - COM2).

PROTOCOL

For the VT-100 terminal port (**VT**), the Protocol setting is always **ui** (user interface).

For the computer (**C1**) port, choose **none**, **ui** (user interface), **pr** (printer), **slip** (Serial Line Interface Protocol), or **ppp** (Point-to-Point Protocol).

For the modem port, choose **ui**, **ui-pr**, or **none**.

RATE

The transmission rate for the VT is **9.6** kbps when selecting protocol setting **ui**. The transmission rates for C1 port when selecting protocol setting **ui** are: **0.3, 1.2, 2.4, 4.8, 9.6** or **19.2** kbps, **9.6** kbps for protocol setting **pr**, **9.6** kbps for protocol setting **slip** and **19.2** kbps for protocol setting **ppp**. The transmission rate for the M port is 2.4 kbps for protocol settings **none**, **ui** and **ui-pr**.

COM CFG

The Communication Configuration settings are always 8 data bits, one stop bit, and no parity (**8,1,N**) for all three ports. You cannot change these settings on any port.

HANDSHAKE

The Handshaking setting is always **none** for all three ports. You cannot change these settings on any port.

MTU

The Maximum Transmission Unit settings are **128 - 1500** when selecting protocol **slip** and **ppp** in the C1 port. The default is **240**.

8.3.6 Interface Card Ports and Functionality

The Interface card controls many critical functions in the system. It provides interfaces to external control devices, terminates all T1 and E1 WAN links, and houses the internal modem. Table 8-8 lists the interface ports and functions. Figure 8-11 shows the component layout and labels the ports.

Table 8-8. Interface Ports and Functions

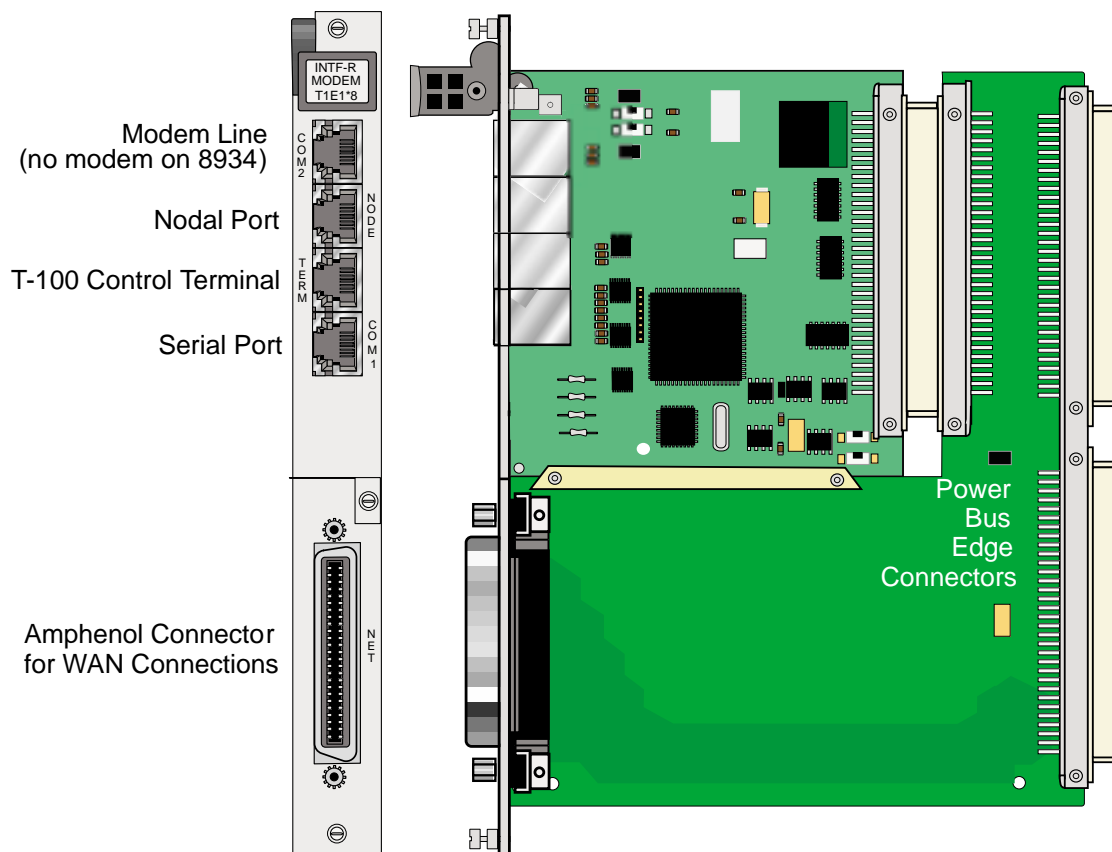

Figure 8-11. Component Layout for the INF-R Modem and INF-R Interface Cards

8.3.7 Using the Node Port

The Node Port allows the system to report ACO (Alarm Cutoff) alarms to an external system to alert the operator to critical situations. Using the ACO function keeps the alarm active until manually cleared from the terminal.

The node port uses an RJ48 connector. Pins 3, 4, and 5 uses an RS485 compatible form c-contact closure that can be used to report ACO alarms to an external system. Pins 1, 2, 6 and 7 are reserved for future use. Pin 8 is ground.

Connection of the ACO alarm interface to an external alarm device (such as a buzzer or light) alerts you to problems with the system. Figure 8-12 shows a possible configuration connecting a unit to a generic external alarm system. The nominal input is 5V and the short-circuit current is 250mA.

The alarm interface is activated by the ACO setting. This will activate the device when a designated alarm occurs.

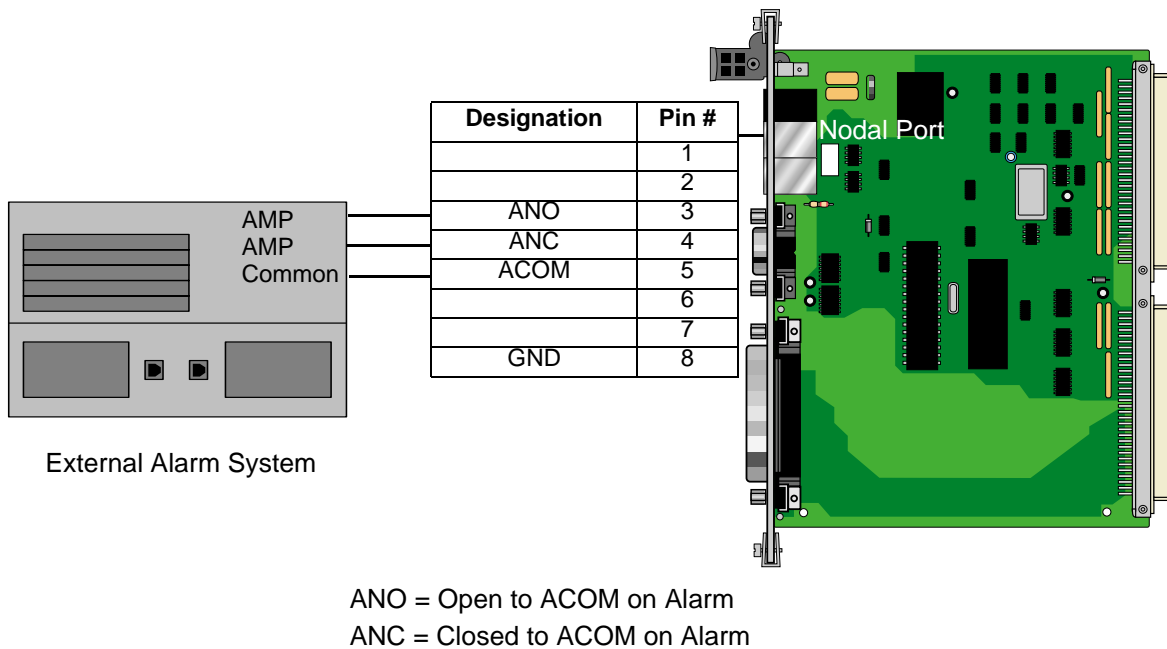

Figure 8-12. Node Port ACO Alarm Interface

8.4 Interface Card Error Messages

Refer to Appendix B in the System Reference Guide for further information on Error Messages regarding this card.

8.5 Interface Card Troubleshooting

8.5.1 User Interface Problems

The Interface card provides the connections from the Integrated Access System to the external control terminals and/or other network management systems. This card may be faulty if you are connected to the system but receive no responses to your commands. However, the problem in this case also may be with the 8803 CPU Card.

First, check the cabling connections from the Interface card to the appropriate external device. Refer to the “Interface Card Description” section at the beginning of this chapter for more information on the card faceplate jacks and signal connections. If possible, substitute a known good cable for the one you suspect is faulty.

If the cable connection is good, unplug the CPU card from the system chassis and then plug it back in to restart the CPU and system. (The problem may have been a momentary system “freeze”.) Then, log into the system again and repeat the command (or series of commands) that initially caused the problem. If the problem continues, replace the Interface card with an identical new card.



Note: *Removal of the Interface card will cause a service disruption on all T1 and E1 WAN links of the system.*

If the problem persists with the new Interface card, the CPU card is probably faulty.

If the Interface card is determined to be faulty, replace it and return the faulty unit for repair to the location specified by your distributor.

8.5.2 Alarm Reporting Problems

The Interface card also provides a relay contact closure to an external alarm annunciation (or other alarm reporting device at the system site) when an alarm is declared. The card may be faulty if an alarm is declared but not indicated on the external alarm reporting system. Check the wiring from the Interface card NODE port to the alarm system. If the wiring is good, replace the Interface card.



Note: *Removal of the Interface card will cause a service disruption on all T1 and E1 WAN links of the system.*

8.5.3 WAN Transmission Problems

A faulty Interface card could cause T1 and E1 WAN service disruptions, since this card also provides the WAN connections. Electrically, the Interface card resides between the WAN cards and the T1/E1 network. If all T1 and E1 links are down (as evidenced by system alarms in progress), first check the cable from the WAN jack of the Interface card to the network. If the cable connection is good, replace the Interface card.



Note: *Removal of the Interface card will cause a service disruption on all T1 and E1 WAN links of the system.*

If the problem is with only one T1 or E1 WAN link, refer to the WAN Chapter in this manual and troubleshoot that link and its associated WAN card. Use the loopbacks provided in the WAN card user interface screens in conjunction with the built-in test patterns you can apply from the Integrated Access System. These test functions allow you to isolate the problem to the local or far (remote) end. You can then check the interconnect cabling from the Interface card to that link, and sequentially replace the WAN and/or Interface card, one by one, until the trouble clears.

8.6 Interface Card Specifications

Interface Cards (Models 893270, 893370 and 893470)

Interfaces

Model	T1/E1 Links	Computer Port	Control Terminal Interface Port	Node Port	Internal Modem	External Sync
893270	8 T1/E1	yes	yes	yes	no	yes
893370	8 T1/E1	yes	yes	yes	yes	no
893470	8 T1/E1	yes	yes	yes	no	no

WAN Ports

Electrical Interface G.703 or DSX-1

Connectors

Model 893270, 893370 and 893470 One Female 50-pin RJ27X telco connector

Computer Port Connectors

Connector RJ-48 Female, 8-pin, EIA 561
 Electrical Interface RS-232, ITU-T V.28
 Function Connects to local Element Management System
 Code Set 8 bit characters plus one start and one stop bit with no parity
 Max Speed 19.2 Kbps (PPP) or 9.6 Kbps (SLIP)

Control Terminal Interface Port

Connector RJ-48 Female, 8-pin, EIA 561
 Electrical Interface DCE RS232, ITU-T V.28
 Function Connect local VT100-compatible Control Terminal local craft interface
 Code Set 8 bit characters plus one start and one stop bit with no parity
 Speed Maximum 9,600 bps asynchronous

Nodal Port

Connector RJ-48 Female, 8-pin
 Electrical Interface Dry contact
 Alarm Output Passive current loop, one normally open loop and one normally closed loop.
 Function Alarm management between co-located Integrated Access System nodes and external alarm management systems and panels.

Modem Port (Model 893370 only)

Connector	Female 6-pin RJ-11C socket
Electrical Interface	600 ohm 2-wire balanced
Protection	HV zener, 0.25A fuses on Tip and Ring
Function	Connect internal modem to PSTN (Public Switched Telephone Network) for access to remote operator and remote EMS network management system.

Modem Specifications (Model 893370 only)

Compatibility	ITU-T V.22 bis
Modulation	16 point QAM
Line Interface	2-wire balanced 600 ohm
Ringer Equivalence	0.2A
Approval	FCC Part 68
Equalization	Receive automatic adaptive transmit fixed compromise
Transmit Level	-9.5 dBm
Receiver sensitivity	ON to OFF threshold -45 dBm OFF to ON threshold -48 dBm
Dialing Mode	DTMF Tone
Speed supported	2,400 bps asynchronous
Code set	8 bit characters plus one start and one stop bit with no parity

Adapters

Model 1106 with 2 BNC connectors	Supports 1 E1 circuit on 75 Ohms coaxial cable (RG59)
Model 1121 with 2 RJ48 sockets	Supports 2 T1 or E1 circuits on twisted pair cable plus bantam jacks for test access.
Model 1181 with 8 RJ48 sockets	Supports 8 T1 or E1 circuits on twisted pair cable
Model 118320 with 16 BNC sockets	Supports 8 E1 circuits (For 891630 Chassis)
Model 1184 with 16 BNC sockets	Supports 8 E1 circuits (For 891830 Chassis)

Standards Compatibility

ITU-T	V.28	Electrical characters for unbalanced double-current interchange circuits.
	V.22 bis	2400 bits per second Duplex Modem Using The Frequency Division Technique
EIA	G.703	Physical/Electrical Characters of Hierarchical Digital I/F
	561	8 Position Non-Synchronous Interface between DTE and DCE Employing Serial Data Interchange
Bellcore CEN	RS232-C	Interface Between DTE and DCE Employing Serial Binary Data
	GR-63-CORE Issue 1	Network Equipment-Building System (NEBS)
	EN 50 081-1	Electromagnetic compatibility generic emission standard Part 1 Residential, commercial and light industry
	EN 50 082-1	Electromagnetic compatibility generic immunity standard Part 1 Residential, commercial and light industry
	EN 60 950/A2	Safety of information technology equipment including electrical business equipment
FCC	Part 68 Subpart B	Requirements for Connection of Terminal Equipment Systems and Protective Apparatus to the Telephone Network
UL	1459	UL Standard for Safety of Telephone Equipment
	1950	UL Standard for Safety of Information Technology Equipment
CSA	C22.2 No. 950	Safety of information technology equipment including electrical business equipment

Chapter 9

WAN Card

9.1 Introduction

This chapter provides installation, configuration, and troubleshooting information for the Wide-Area Network (WAN) Cards. These include the WAN DUAL (801060 and 801070), WAN-R DUAL (801460 and 801470) Cards. These designations are marked on the faceplate ejectors of the associated cards. Throughout the remainder of this chapter, these cards are referred to as the WAN DUAL, and WAN-R cards, respectively.

The WAN cards manage the flow of data through the Integrated Access System network. They terminate T1 and/or E1 lines and generate or receive network timing clocks. They also cross-connect DS0 time slots, to pass data through the system from one T1 or E1 line to another.

9.2 WAN Card Descriptions

9.2.1 WAN DUAL Card with CSU Support Description (801070)

The 801070 WAN DUAL card with CSU support connects up to two T1 or E1 lines or CSU lines, or one of any type. The 801070 WAN card does not use any plug-in modules, the 801470 card does require a plug-in relay card. When only one DSX/CEPT or CSU is configured, the other WAN port will remain in the standby state. **However, a CGA-Red alarm will be generated for that port.**

The 801070 card is a replacement for the 801060 WAN card, and is backwards compatible with earlier releases of the IMACS platform. This capability is achieved via a software load that is used on the card. This capability does require a boot-up sequence on the card, which differs from the 801060 WAN card. Where the 801060 and 801460 WAN cards would be in-service almost the second it was placed into the shelf, the 801070 card and the 801470 card does require about thirty seconds to come up into service from the time it becomes shelf powered.

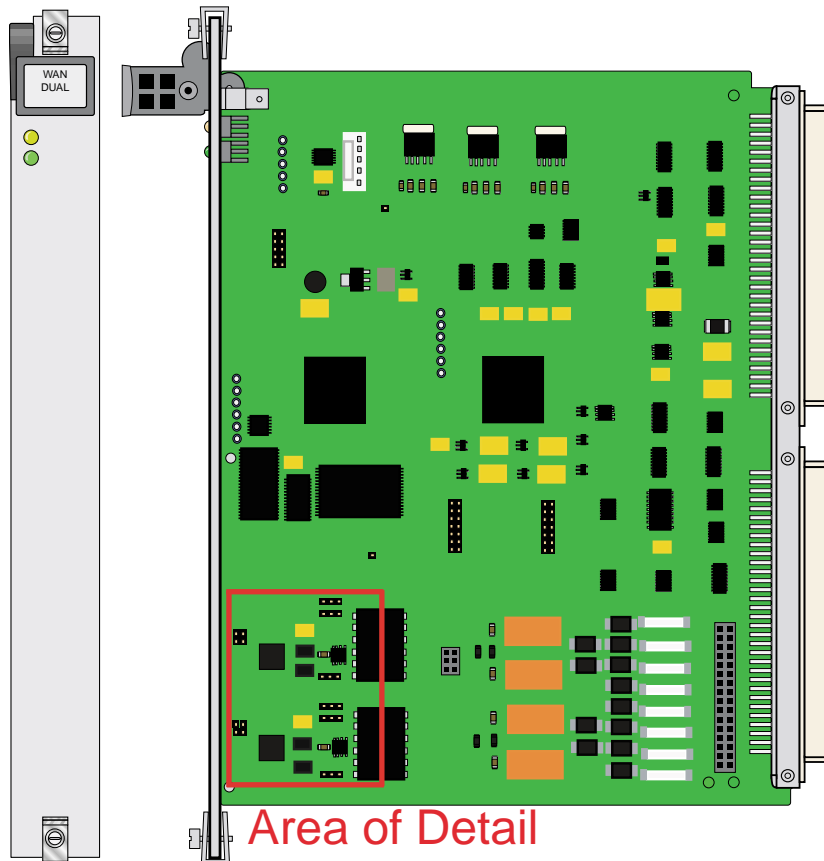

Figure 9-1. WAN DUAL Card with CSU Support (801070)

9.2.1.1 Card Jumper/Switch Settings

The 801070 card utilizes jumpers to set each of the two ports for T1, E1 or T1 CSU. These straps are located in the “Area of Detail” as seen in Figure 9-1 on page 9-2, and shown in greater detail in Figure 9-2.

The straps on the 801070 and 801470 are used instead of the previous daughter boards with straps to set the line parameters on the 801060 and 801460 cards.

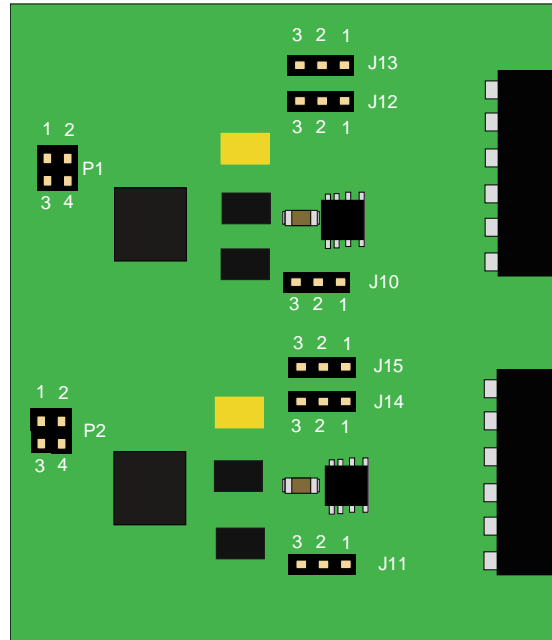

Figure 9-2.801070 Strap Settings for T1, E1 and T1 CSU

The 801070 Dual WAN supports two interfaces, and the straps shown in Figure 9-2 detail the different ports and respective jumpers. Port 1 on the interface is labelled as P1, and the associated jumpers for setting parameters on the port are labelled as J10, J12 and J13. The second port on the 801070 card is identified as P2 in Figure 9-2, and the associated jumpers for setting parameters on the port are labelled as J11, J14 and J15.

For T1 CSU mode, no straps are used. Each port should have all the straps removed in order to provide the T1 CSU interface. For example, if P1 is desired to run as a T1 CSU interface, then the straps as identified in Figure 9-2 should be removed from P1, J10, J12 and J13.

For T1 DSX mode, only the Port strap itself is used, and the strap on P1 should be placed on pins 1 and 2, as identified in Figure 9-2. The straps on J10, J12 and J13 can be either be between 2 and 3 (factory default) or removed.

For E1 CEPT mode, then all the respective straps for the port will be used. The port strap should be placed across pins 3 and 4, and the respective parameter setting straps will be utilized. For a 75 Ohm termination, parameter jumpers should be placed across pins 1 and 2. For an E1 interface with 120 ohm impedance, then the straps should be placed across pins 2 and 3. In other words, if Port 1 is desired to be in E1 mode with a 120 Ohm termination, then P1 should be strapped on pins 3 and 4, and J10, J12 and J13 should all be strapped on pins 2 and 3. These strapping options are summarized in Table 9-1 on page 9-4.

Table 9-1. 801070 WAN Strap Setting Options

WAN Interface Type	P1	J10 J12 J13	P2	J11 J14 J15
T1 DSX Mode	1-2	None or between 2 and 3	1-2	None or between 2 and 3
T1 CSU Mode	None	None	None	None
E1 with 75 Ohm Termination Impedance	3-4	1-2	3-4	1-2
E1 with 120 Ohm Termination Impedance	3-4	2-3	3-4	2-3

9.2.1.2 WAN Software Level

The version of the software contained in the WAN card is able to be determined by the craftsperson. At the time of introduction, the load on the WAN is version 1.0.2. The craftsperson can determine this information by looking at the serialization of the card. To do so, login into the IMACS shelf, and position the cursor on the 801070 or 801470. Execute the sEr command by hitting the “E” from the keyboard. A display will pop-up as in Figure 9-3, and the area identified shows that this WAN is running version 1.0.2 of the software.

Starting in the 6.1.1 release is the ability to poll the systems using SNMP to retrieve the same information. This enhancement provides the customer the ability to remotely poll the IMACS systems to retrieve the WAN software level in the entire network. This change is in the IMACS software only; no new MIBs are required. The interface to the IMACS to retrieve this information is in the standard MIB definitions, specifically in the OID found at:

.iso.org.dod.internet.mgmt.mib-2.interfaces.ifTable.ifEntry.ifDescr or OID
.1.3.6.1.2.1.2.2.1.2.

Following is an example of the data returned when the customer issues the MIB command:

```
6001 : WAN8010; DSX+DSX; Rev E3-000 Ser 18791 FWRel 000000; s:w1; u:1; State: act
6002 : WAN8010; DSX+DSX; Rev E3-000 Ser 18791 FWRel 000000; s:w1; u:2; State: act
7001 : WAN8010; CEPT+CEPT; Rev F0-000 Ser 00858 FWRel 000000; s:w2; u:1; State: act
7002 : WAN8010; CEPT+CEPT; Rev F0-000 Ser 00858 FWRel 000000; s:w2; u:2; State: act
8001 : WAN8010; DSX+DSX; Rev E3-000 Ser 16975 FWRel 000000; s:w3; u:1; State: stby
8002 : WAN8010; DSX+DSX; Rev E3-000 Ser 16975 FWRel 000000; s:w3; u:2; State: act
9001 : WAN8014; DSX+DSX; Rev A3-000 Ser 00005 FWRel 010009; s:w4; u:1; State: stby
9002 : WAN8014; DSX+DSX; Rev A3-000 Ser 00005 FWRel 010009; s:w4; u:2; State: stby
```

Note that the standard WAN cards display FWRel of 000000, whereas the new WAN cards display values other than 000000. The data returned by this query is in hex, so that decimal ten will display 000A, eleven will be 000B, and so on. In the example above, the WAN card in slot w4 returned the value of 010009, indicating that this card is running the 01.00.09 WAN

software load. Only the WAN cards return the string of FWRel, so searching the returned data to parse the information is convenient. Note also that the state of the card does not preclude the customer from receiving this information.

```

unknown      | 05-21-08 08:17
Slot W1  Model 8010  wan 2      Rev A0-000  Serial 00026

05ff 001a 4100 0000 0000 0000 0000 0000
fe05 1408 ffff 0000 0000 0000 0001 0002
                                     |  |
                                     1. 0. 2

Write : Main

```

Figure 9-3.WAN Software Level

9.2.1.3 WAN Software Download

CPU load 6.1.1 in conjunction with WAN load 1.0.9 enables the 880370 CPU to write to the on-board flash memory on the PRM-801070 and PRM-801470 WAN cards. Previous releases of the WAN cards with software loads 1.0.1 through 1.0.7 do not have the ability to write to the on-board flash and thus required that the card be returned to Zhone or Zhone's designee to be re-programmed. The 1.0.9 WAN load requires complementary software on the CPU card to properly send, receive and write to the flash device on the WAN card. The CPU software levels which enable the WAN download are software releases 6.0.5 and above.

The WAN download feature is similar to what other IMACS cards already allow, such as the MCC, ACS, FRAD, IPR, and LD-SRU cards. On the main screen, position on the card that you would like to download to. In our case, position on the WAN card that contains 1.0.9 or higher. To check the WAN load currently in use, hit the 'E' (sEr for serialize) key to determine the WAN load in use. A display will appear, similar to the one seen in Figure 1, below. If the load shown is 1.0.7 or below, then this WAN card CANNOT be downloaded and flash download should not be attempted. Should the user try to download to the card with software at release 1.0.7 or lower, the CPU will attempt to download to the card but the load will not be written to the card.

```

WAN download | 02-19-10 12:55
Slot W3/U7 Model 8010 wan 2 Rev A3-000 Serial 00020 OOS U5
OOS P3

05ff 0014 4103 0000 0000 0000 0000 0000
fe03 1200 ffff 0000 0000 0000 0001 0007
                |  |
                |  |
                1.0.7

Write | Main
    
```

Figure 9-4.WAN load 1.0.7

If the load displayed from the serialization command above is 1.0.9 or higher, then this card can be downloaded from the CPU as long as the CPU is at software release 6.0.5 or higher. On the initial login to the IMACS, position on the WAN load to be downloaded (the card must be a PRM-801070 or PRM-801470) and hit the 'P' key for program. The WAN download screen will appear, as shown in Figure 2. If the download screen does not appear, then either the CPU load does not support the feature (software release 6.0.4 or below), or the WAN card is not a PRM-801070 or PRM-801470. In this latter case, the CPU should report " This card is not listed as having flash memory...". When the card is a PRM-801070 or PRM-801470, and the CPU is at Software release 6.0.5 or higher, a screen similar to Figure 9-5 below appears.

```
Flash Screen | W1/U5 DSX+DSX | Rev A0-0 Ser 00002 | 03-04-10 11:5
BLOCK NUMBER:      1                                005 U5
STATUS              actv                            005 W4
MODEL               wan 2                           005 W3
VERSION             1.0.9                           005 P3
I.D.                1
CHKSUM              0xB8C029

Copy | Refresh | Main
```

Figure 9-5.WAN Download screen

Since this screen appears and the WAN load is 1.0.9 or higher, a download can commence on this card.

NOTE: A WAN card running 1.0.7 or below will appear to download using software release 6.0.5 or higher if attempted. However, the load will never be written to flash, and the card will remain on the load currently installed. No corruption will be caused by entering into this process on a card that does not support this flash download feature.

To start the download, hit carriage return on the block that shows "actv". A menu similar to Figure 9-6 below appears.

```

Flash Screen | W1/U5 DSX+DSX | Rev A0-0 Ser 00002 | 03-04-10 12:00
BLOCK NUMBER:      1
STATUS             actv
MODEL              wan 2
VERSION            1.0.9
I.D.               1
CHKSUM             0xB8C029
OOS               U5
OOS               W4
OOS               W3
OOS               P3

actv  deactiv  dnload
Copy  Refresh  Main

```

Figure 9-6.WAN Download Options

To download the new software, use the arrow key to move over to the 'dnload' option. The user will be presented with a question: "Are you sure you want to overwrite this block (y/n)?". Select 'y' to confirm the process. New in release 6.1.2, after the user confirms that the download is desired, the system will raise an UPGRADE alarm, noting the WAN card being upgraded. The user will then be presented with the option to use XMODEM or TFTP. The XMODEM option is supported only via a direct connection to the IMACS unit. Should the customer attempt to use the XMODEM option on a telnet session, the IMACS will respond with "Error, a modem connection is needed to start the XMODEM transfer...". In this case, you must choose the TFTP option. The upgrade will take approximately three minutes, depending on latency in the network. The user must have a TFTP server set up in order to choose the TFTP process. If the user chooses an option they wish to change, simply hit cntl-x to abort the loading function.

TFTP download process

Once TFTP has been chosen, the user will be presented a series of questions. Use the defaults when prompted. Following are the questions and the correct way to initiate the download:

Mismatch retries: Hit carriage return to select the default value of 20.

Timeout retries: Hit carriage return to select the default value of 4.

IP Address of server: Enter the IP address for the TFTP server which is pointing to the location for the new WAN load.

File name: Enter the name of the load, for example WAN1010.bin

Once all the parameters have been chosen and the TFTP server is properly started and configured, the WAN load should start being transferred to the PRM-801070 or PRM-801470 WAN card. Figure 4 below shows a snapshot of the TFTP load being sent over the communications channel. The 'Bytes left' field will automatically decrement as more of the load is transferred, showing a smaller and smaller 'Bytes left' count remaining to be sent.

```
Flash Screen | W2/U6 DSX+DSX | Rev A0-0 Ser 00005 | 02-19-10 10:34
BLOCK NUMBER:      1 | OOS U5
                   | OOS P3
STATUS             empty
MODEL              ---
VERSION            ---
I.D.               ---
CHKSUM             ---

Press CTRL-X to abort transfer...
Bytes left: 484146
```

Figure 9-7. TFTP Download in Progress

After the download has completed, the WAN status, Model, Version, ID and checksum will appear. The display will indicate the load that is presently written to flash, which will be the old load (the one being upgraded from). After the load is transferred, the system will perform a checksum on the file that has been delivered.

NOTE: The card will automatically restart to activate the new load. Once the TFTP process has completed, the card will take an additional 30 seconds to complete the load installation. The user will not be notified of a successful TFTP download on this screen, but rather by the generation and clearing of a WAN OOS alarm.

Assuming the checksum operation passes, the card will automatically perform a restart operation and install the new load. Watching the alarm banner in the upper-right screen should display the WAN going OOS and then that alarm clearing. This indicates that the card is now running the new load and that the new load has been successfully written to flash. To validate this, the user would need to exit and re-enter the download screen to see the new information. The load displayed should now reflect the information from the load sent via the TFTP

process. Alternatively, the user could go back to the serialization screen to observe the load running on the WAN card (seen in Figure 9-4 at the beginning of this procedure). Should the checksum function not pass, then the user will be prompted to try the download action again.

Once the download has completed or failed, then the system will clear the UPGRADE alarm.

XMODEM download process

The user could also select the XMODEM method to update the card. If XMODEM is selected the screen seen in Figure 5 appears. The capital "C"s appearing in the download screen indicates that the XMODEM is active. The user must use the terminal communications package to send the file in XMODEM format. Again, this process will take around an hour to complete.

```
Flash Screen | W4/U8 DSX+DSX | Rev A3-0 Ser 00005 | 02-19-10 13:40
BLOCK NUMBER:      1 |                                00S    U5
                   |                                00S    P3
STATUS             empty
MODEL              ---
VERSION            ---
I.D.               ---
CHKSUM             ---

CCC
```

Figure 9-8.XMODEM download screen

After the download has completed, the WAN status, model, version, ID and checksum will appear. The display will indicate the load that is presently written to flash, which will be the old load (the one being upgraded from). After the load is transferred, the system will perform a checksum on the file that has been delivered.



Note: *NOTE: The card will automatically restart to activate the new load. Once the XMODEM process has completed, the card will take an additional 30 seconds to complete. The user will be notified of a successful XMODEM download by the generation and clearing of a WAN OOS alarm.*

Assuming this checksum operation passes, the card will automatically perform a restart operation and install the new load. Watching the alarm banner in the upper-right screen should display the WAN going OOS and then that alarm clearing. This indicates that the card is now running the new load, and has been successfully written to flash. To validate this, the user would need to exit and re-enter the download screen to see the new information. The load displayed should now reflect the information from the load sent over via the XMODEM process. Alternatively, the user could go back to the serialization screen to observe the load running on the WAN card (seen in Figure 1 at the beginning of this procedure). Should the checksum function not pass, then the user will be prompted to try the download action again.

Once the download has completed or failed, then the system will clear the UPGRADE alarm.

9.2.2 WAN DUAL Card Description (801060, 801065)

The WAN DUAL card connects to two T1 or E1 lines, or to one of each type. The works with only one DSX/CEPT or CSU plug-in module if the WAN port without either module remains in the standby state (see Figure 9-9). **However, a CGA-Red alarm will be generated for that port.** The WAN DUAL (801060) card works with DSX/CEPT module (81130) and CSU Module (81230) referred to later in this section.

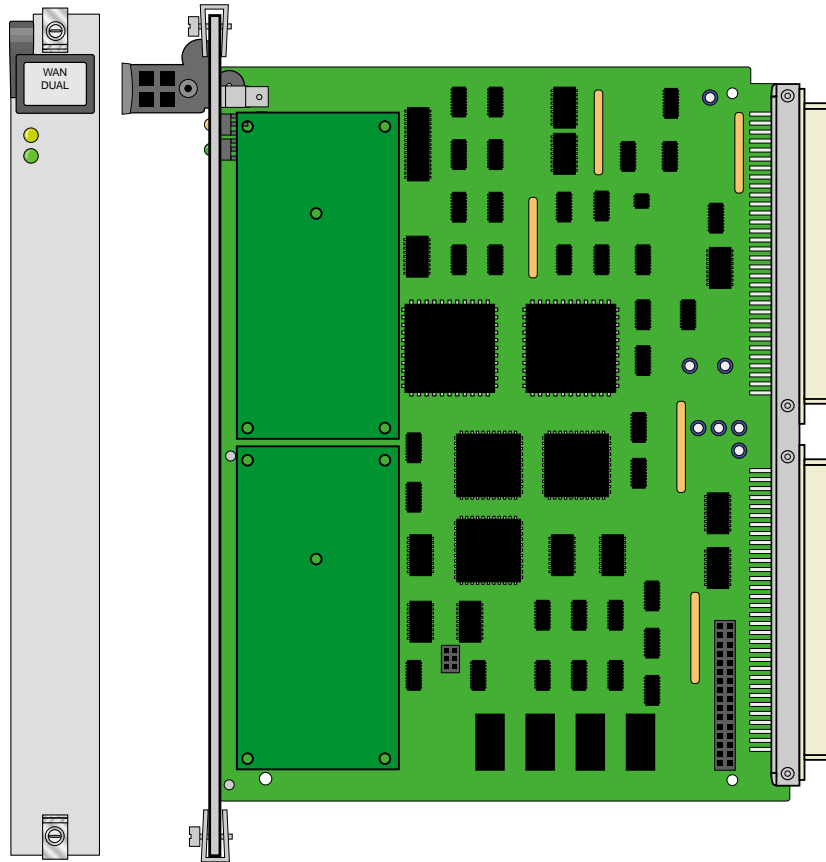

Figure 9-9. WAN DUAL Card (801060)

9.2.2.1 Card Jumper/Switch Settings

The WAN DUAL card does not have any jumpers or switches on its motherboard.

9.2.3 WAN-R Card Description (801460)

The WAN-R card is a dual-T1/E1 card with relays for use in CPU XCON systems with redundant WAN cards. When placed in slot W4 of a chassis, this card acts as a redundant (backup) card for up to three standard WAN cards in slots W1, W2, and W3. This arrangement is known as 1-in-N redundancy, where N is the number of working (primary) WAN cards supported. If a working WAN card fails, the relay on the WAN-R card in slot W4 will switch its output to the correct pins on the WAN connector of the associated Interface card in the system. If the WAN-R card is placed in any other chassis slot, it works like a regular WAN DUAL card. The WAN-R (801460) card works with CSU module (81230).

9.2.3.1 Card Jumper/Switch Settings

The WAN-R card does not have any jumpers or switches on its motherboard.

9.2.4 WAN-R Card Description (801470)

The 801470 WAN-R card is a dual-T1/E1 card with relays for use in CPU XCON systems with redundant WAN cards. When placed in slot W4 of a chassis, this card acts as a redundant (backup) card for up to three standard WAN cards in slots W1, W2, and W3. This arrangement is known as 1-in-N redundancy, where N is the number of working (primary) WAN cards supported. If a working WAN card fails, the relay on the WAN-R card in slot W4 will switch its output to the correct pins on the WAN connector of the associated Interface card in the system. If the WAN-R card is placed in any other chassis slot, it works like a regular WAN DUAL card.

9.2.4.1 Card Jumper/Switch Settings

The WAN-R card has the same strap settings as described in “WAN DUAL Card with CSU Support Description (801070)” on page 9-1. The straps on the 801470 must match the strap settings for the traffic-bearing 801070 card. Refer to Table 9-1 on page 9-4 to the settings allowable for the 801470 card.

9.2.4.2 WAN Software Level

The 801470 card has a software level, and can be identified as outlined on page 9-4.

9.3 WAN Module Descriptions

9.3.1 DSX/CEPT Module Description (81130)

The DSX/CEPT module supports either the T1 DSX or E1 CEPT mode. It mounts on the WAN SINGLE, WAN DUAL, and WAN-R cards. These cards are not employed by the 801070 or 801470 WAN and WAN-R cards. The CEPT function of the DSX/CEPT module is used for connection to a 2.048 Mbps E1 network. Jumper settings are provided on the module to select either DSX or CEPT operation. All WAN cards equipped with DSX/CEPT modules also act as the "remote terminal" termination points for the Subscriber Loop Carrier (SLC-96) facilities defined in Bellcore publication TR-TSY-000008, Issue 2, August 1987.

9.3.1.1 DSX/CEPT Module Jumper Settings

After installing the DSX/CEPT modules, set their jumpers for either DSX (T1) or CEPT (E1) operation. These jumpers are factory-set for DSX. To convert a module to CEPT, reset the jumpers as described below. The actual jumper locations will depend on which module version you have.

9.3.1.2 DSX/CEPT Module Installation

For DSX or CEPT operation, you must install one of these modules on the associated WAN card before inserting those cards into the system chassis. Figure 9-10 shows the locations of the DSX/CEPT modules on a WAN card. One module is required per WAN port. If your system has a T1 link (DSX) and an E1 link (CEPT), you will need two DSX/CEPT modules.

First, install a DSX/CEPT module in the slot reserved for WAN port 1-1. Insert the pins for TX into socket JP10 on the WAN card (see Figure 9-10), while also inserting the pins for RX in JP9 and the 24-pin end connector pins in JP6. Then, for a WAN DUAL card, install another DSX/CEPT module in the WAN port 1-2 location, and plug that module into JP13, JP14, and JP15.

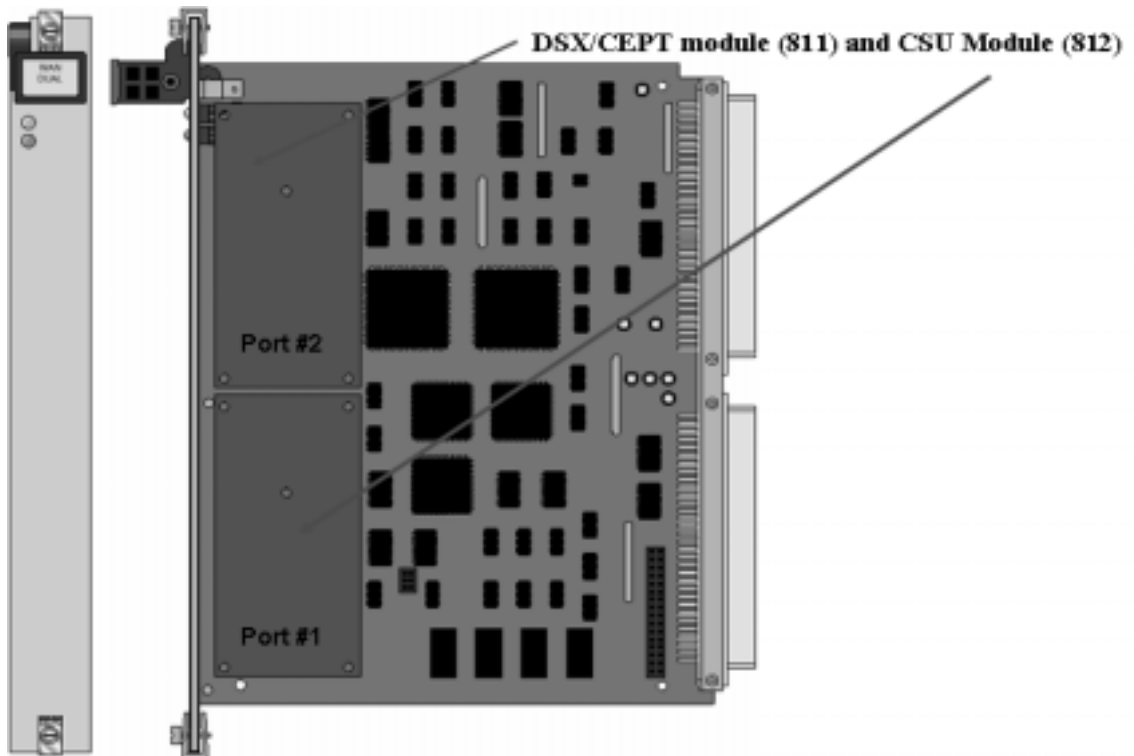

Figure 9-10. Installing DSX/CEPT Modules (8010)

9.3.1.3 DSX/CEPT Module

The DSX/CEPT Revision F module is shown in Figure 9-11. These modules may be optioned for T1, 120-ohm balanced E1, or 75-ohm unbalanced E1, as shown in Figure 9-12. The jumper option configuration is silk-screened on the card.

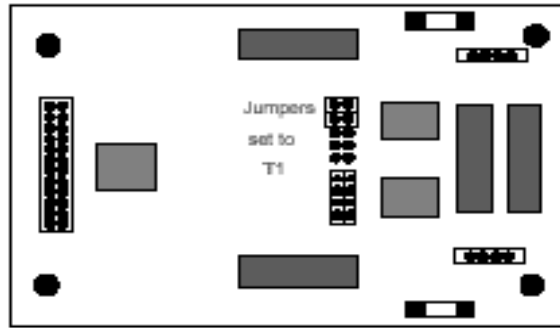

Figure 9-11.DSX/CEPT Module (Jumpers set forT1) (81130)

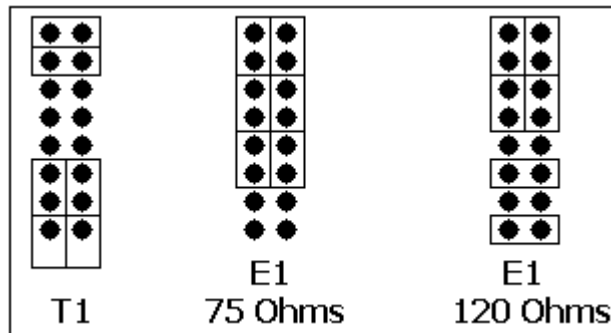

Figure 9-12.DSX/CEPT Module Jumper Settings (81130)

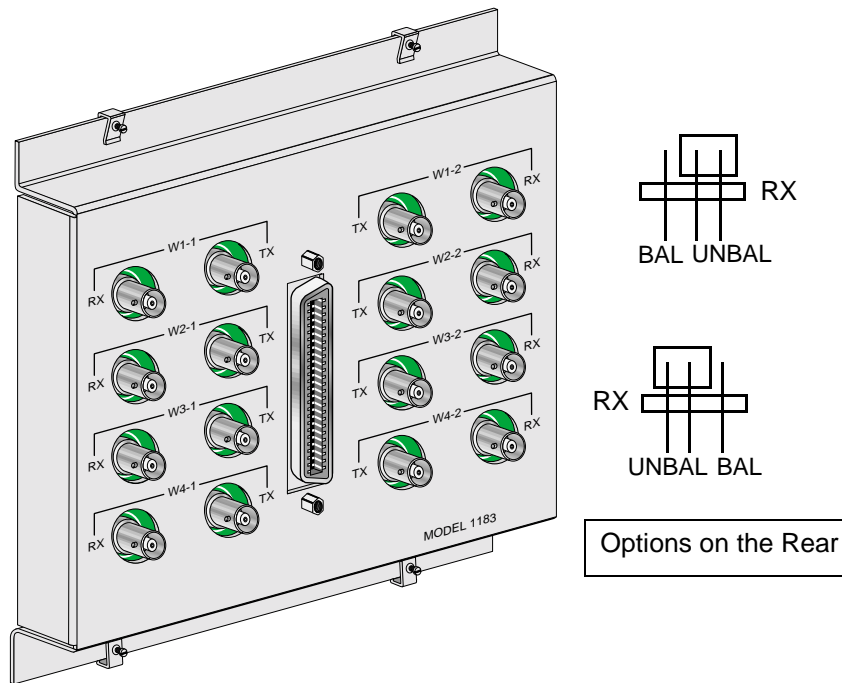

Figure 9-13.E1 Interface Adapter Panel (11830 or 1184)

For 120-ohm balanced E1 operation, set the jumpers on the adapter panel as shown in Figure 9-13. **Both** DSX/CEPT Modules should be set for balanced operation prior to installation.

For 75-ohm unbalanced E1, set the adapter panel jumpers to UNBAL **in one location only**, and set them to BAL in all other cases. When multiple DSX/CEPT modules with jumpers are installed, the unbalanced jumper should be set on the module closest to the E1 line. When the adapter panel is present, it is considered the unit closest to the E1 line. The corresponding jumpers on the rear of the panel are set to UNBAL while all other module jumpers are set to BAL.

9.3.2 CSU Module Description (81230)

The CSU module is required for Channel Service Unit (CSU) operation on a T1 line. This module mounts on the WAN SINGLE, WAN DUAL, and WAN-R cards, as shown in Figure 9-10. All WAN cards equipped with CSU modules also act as the "remote terminal" termination points for the Subscriber Loop Carrier (SLC-96) facilities defined in Bellcore publication TR-TSY-000008, Issue 2, August 1987.

9.3.2.1 CSU Module Installation

Install the CSU module on the associated WAN card by plugging its connector pins into the mating sockets of the WAN card, as shown in Figure 9-10. For a WAN DUAL or WAN-R card, you can install two modules.

9.3.2.2 CSU Module Jumper/Switch Settings

The CSU module does not have any jumpers or switches.

9.3.3 Installing the WAN Cards

After installing the proper modules on the WAN cards (not applicable on the 801070 and 801470 cards) and setting the proper jumper settings, insert the WAN cards into the system chassis. Each system can have up to four WAN cards, which go into slots W1 through W4.

For a system with redundant WAN cards, always insert a WAN-R card into slot W4. If you install the WAN-R card into any other WAN card slot, it will work as a regular WAN card (not as a redundant card). Also make sure that the WAN-R card has the same types of modules installed on it as the associated primary WAN cards, and that those modules are installed in the same positions (ports 1 and 2), as shown in Figure 9-10.

9.3.3.1 WAN-rr alarms

New in CPU-7 are WAN RR alarms. If the WAN card is in protection mode, then it effectively only would provide 1+1 protection for the card that had caused the protection activity, instead of providing n+1 protection for the three other WAN cards in the shelf. In order to flag this to the user, we have added a WAN RR alarm to the user interface and SNMP trap to notify that a WAN protection switch has taken place and the system is no longer providing 1+n protection.

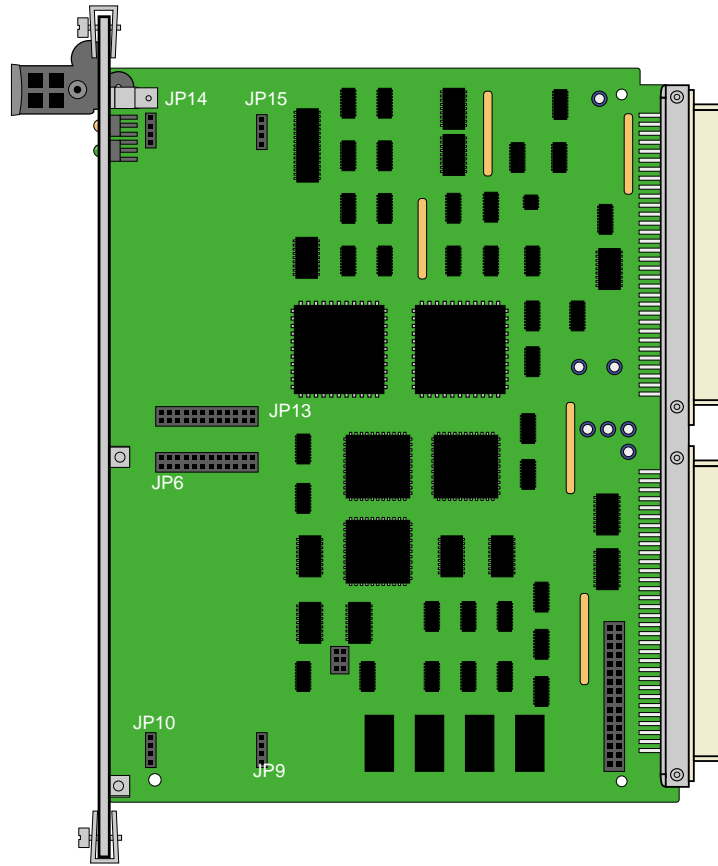

Figure 9-14.Installing DSX/CEPT Modules

9.4 WAN Card User Screens and Settings

9.4.1 T1 CSU and DSX Settings

The DSX/CEPT and CSU Modules for T1 operation have identical configuration parameters, which you must set on, the WAN Card Main Screen. To go to that screen, select the desired WAN card on the System Main Screen, then press <Enter>. Figure 9-15 shows a typical WAN Card Main Screen for T1 CSU or DSX operation.

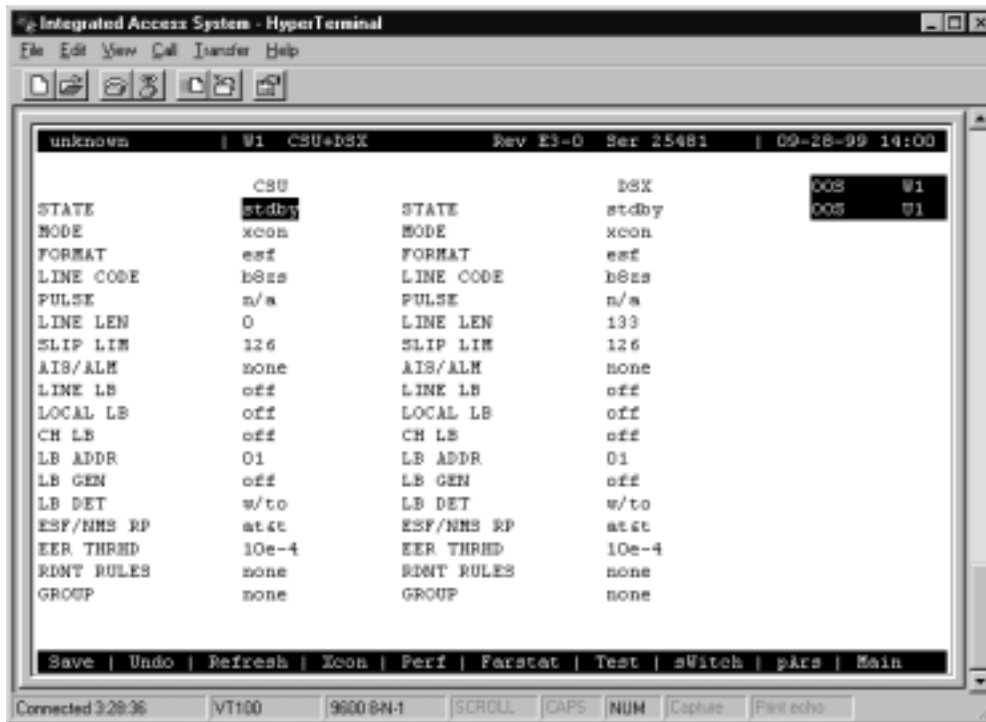

Figure 9-15. WAN Card Main Screen for T1 CSU and DSX

The headers of all WAN card screens show the types of modules installed on those cards. The above example shows a WAN DUAL card with a CSU module on port 1 and a DSX/CEPT module configured for T1 DSX operation on port 2. This card is installed in WAN card slot W1 of the system. Its screen header designation is therefore **W1 CSU+DSX**.

The DSX/CEPT and HDSL modules also have identical parameters. These are described in the next section of this chapter.

Table 9-2 lists several actions you can perform from the WAN Card Main Screen. These actions appear in the bottom-highlighted line of the screen. To perform an action, simply press the key corresponding to the capital letter of the desired action. For example, to save your parameter settings, press “s” to invoke the **Save** commands.

Table 9-2. T1 CSU and DSX Main Screen Actions

Action	Function
Save	Saves changes to settings
Undo	Returns all settings to the last saved state.
Refresh	Updates certain time-related information fields that are not automatically updated (e.g., performance and test data).
Xcon	Shows the cross-connect map for each WAN port.
Perf	Brings up the Performance Data Screen for the near-end system. See the Performance Data section of this chapter.
Farstat	Brings up the performance data for the far-end system. See the Far-End Data section of this chapter.
Test	Initiates and monitors testing of all WAN card ports. Refer to the Test section of this chapter.
sWitch	Allows you to switch WAN port operation to the redundant (WAN-R) card.
pArs	PARS (Premisys Automatic Rerouting System) feature protects the traffic of a failed T1/E1 transmission line in a ring network. The PARS feature is not supported in CPU-7.
Main	Returns to the System Main Screen. If changes are made to settings and not saved, you will be prompted to save or lose changes.

Table 9-3 lists the CSU/DSX settings on the screen, along with their possible and default values. For information about cross-connects and for the DS0 time slot map used to connect your WAN to voice and data user cards.

In addition to the Local and Line Loopbacks described below, a single or dual WAN card with a CSU Module will recognize and respond to industry-standard T1 loop-up and loop-down codes generated and applied from the network or a remote device. However, the WAN card will ignore those codes if it has a DSX/CEPT Module.

Table 9-3. T1 CSU and DSX Option Settings and Defaults

Parameter	User Options	Notes	Default
STATE	stdby actv		stdby
MODE	xcon	1	xcon
FORMAT	d4 esf slc96 slcd4		esf
LINE CODE	ami b8zs	2	b8zs
PULSE	n/a trnsp z15s		n/a
LINE LEN	0 7.5 15.0	3	0
SLIP LIM	126 138		126
AIS/ALM	none tcodr	4	none
LINE LB	off on		off
LOCAL LB	off on		off
CH LB	off clr		off
LB ADDR	01-24		01
LB GEN	off llb plb nlb		off
LB DET	w/to off on		w/to
ESF/NMS RP	none at&t ansi c-fdl c-b7r e-fdl	5	at&t
EER THRHD	10e-4 thru 10e-9 none		10e-4
RDNT RULES	n/a none OOS CGA	6	none
GROUP	none 1 2 3 4	7	none

Notes:

1. The only valid option for Cross-Connect systems is **xcon**.
2. These options are valid only if you have a CSU and the Line Code is **ami**. If you have a CSU and the Line Code is **b8zs**, then this setting will default to **n/a**. If you have a DSX module, then this setting will always default to **n/a**.
3. These options are valid only if you have a CSU. If you have a DSX module, then the possible options are **0** (default), **133**, **266**, **399**, **533**, **655**, and **csu**.
4. The settings for AIS/ALM are affected by the setting of Group.
5. If the format is d4 or slc96, the only option to appear will be **none**.
6. If there is no redundant WAN card in the appropriate slot the only option that will appear is **n/a**.
7. Selection of GROUP is a two-step process. After identifying the group number (1-4), the user must select the secondary group (A, B, or C). At which point TCO DR will then become available.

STATE

In the standby state, the WAN port is electrically disconnected from the network. Set this field to **stdby** (standby) while configuring WAN links, and then change it to **actv** (active) when starting normal operations. If the WAN is in loopback due to a command from a remote device, the loopback will be dropped if you switch to **stdby**.

MODE

In cross-connect systems, the Mode automatically defaults to (**xcon**).

FORMAT

The Format setting specifies the frame format to be used on the WAN link so that it matches the frame format used by the T1 carrier. Set the Format parameter based on the type of frame format the T1 carrier requires. If you are using an external Channel Service Unit (CSU), the frame format must match that of the CSU. The options are **d4** (normal superframe), **esf** (extended superframe), **slc96** (subscriber loop carrier) and **slcd4** (subscriber loop carrier - D4).

Table 9-4 lists the DS0 time slots and their corresponding SLC[®] assignments, based on Bellcore TR-TSY-000008.

LINE CODE

The Line Code setting matches the Line Code used by the T1 interface to that used by the T1 network. Set the Line Code to the type of Line Code used. If you are connected to an external CSU, the line code must match that of the CSU. The options are **ami** and **b8zs**.

PULSE

CSU modules with the Line Code configured for **ami** mode requires the WAN system or the attached customer equipment ensure pulse density (also known as ones density). In **z15s** mode, the system will monitor the outbound data stream and will place a "1" in the 16th bit position whenever it detects fifteen consecutive zeros. In the transparent mode (**trnsp**), the system will pass all incoming data (the DTE must provide 1s density). If the Line Code parameter for the CSU is **b8zs**, the Pulse option will default to **trnsp**. If the WAN link is equipped with a DSX plug-in module, this option will automatically default to **n/a**.

LINE LEN

The Line Length setting adjusts the T1 power level to compensate for the distance the signal must travel before it reaches the first T1 line repeater or other device. For a DSX interface, the options are **133**, **266**, **399**, **533**, and **655** feet. Or, choose **csu** to connect the DSX module to the equipment side of a collocated external CSU.

SLIP LIM

The Slip Limit defines how many bits of wander the WAN port will tolerate before forcing a frame slip. The options are **126** bits and **138** bits, which correspond to an older and a more recent version of the specification, respectively.

Table 9-4. DS0-to-SLC-96 Time Slot Conversion

Time Slot	SLC Channel Number			
	Shelf A	Shelf B	Shelf C*	Shelf D*
1	1	25	49	73
2	13	37	61	85
3	2	26	50	74
4	14	38	62	86
5	3	27	51	75
6	15	39	63	87
7	4	28	52	76
8	16	40	64	88
9	5	29	53	77
10	17	41	65	89
11	6	30	54	78
12	18	42	66	90
13	7	31	55	79
14	19	43	67	91
15	8	32	56	80
16	20	44	68	92
17	9	33	57	81
18	21	45	69	93
19	10	34	58	82
20	22	46	70	94
21	11	35	59	83
22	23	47	71	95
23	12	36	60	84
24	24	48	72	96

* Shelves C and D not supported in this release

AIS/ALM

The AIS/ALM (Alarm Indication Signal/Alarm) setting allows you to specify the type of “keep-alive” signal the system will generate on one T1/E1 link if the other one fails. The AIS/ALM setting depends on the Frame Format selected for this WAN card. Table 9-5 shows the AIS/ALM settings for cross-connect systems.

Table 9-5. AIS/ALM Settings

System	Frame Format	AIS/ALM
Cross-Connect	D4	none, tcodr
	ESF	none, frm, unfrm
	SLC-96	note, orb13, orb16

In a cross-connect system, the options available for D4 or ESF frame format are **none** (no AIS signal is generated) and **tcodr** (transcoder operations). You can choose **tcodr** only after selecting the Group option described later in this section. The options for SLC-96 frame format are **note** (network office terminating equipment), **orb16** (Office Repeater Bay–16 frames), and **orb13** (Office Repeater Bay–13 frames). The AIS/ALM option for the SLCD4 format defaults to **n/a**.

LINE LB

The Line Loopback setting loops the T1/E1 line back toward the network, as shown in Figure 9-16. This loopback also continues sending the incoming data toward the CPE. Choosing **on** allows you to test the end-to-end T1/E1 circuit path from the far end. Choosing **off** disables the loopback and restores the normal signal path in both directions. If the WAN is in loopback due to a remote device, the loopback will be dropped if you choose **on**.

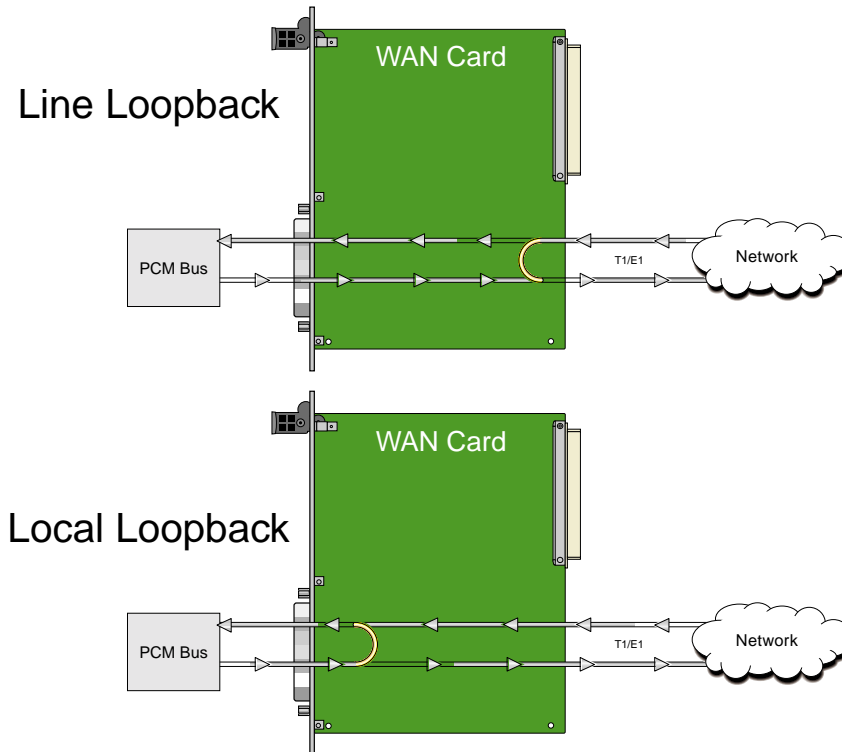

Figure 9-16. Line and Local Loopbacks

LOCAL LB

The Local Loopback setting allows you to loop the full T1/E1 line back toward the CPE, as shown in Figure 9-16. This loopback also continues sending CPE data toward the network. Choosing **on** allows you to test the local system. Choosing **off** disables the loopback and restores the normal signal path in both directions. If the WAN is in loopback due to a command from a remote device, the loopback will be dropped if you choose **on**.

CH LB

The Channel Loopback setting allows you to loop the data in an individual DS0 time slot on the WAN link toward the CPE (see Figure 9-17). However, you cannot use this feature to loop multiple time slots or any portions of them. Refer to the user card chapters for other loopback options that may allow you to loop part of a time slot or multiple time slots.

The loopback setting can be **off** or **clr** (clear). Clear means the entire 64 kbps clear-channel time slot will be looped back, but without the Robbed-Bit Signaling data that may normally be embedded in the time slot. If the WAN is in loopback due to a command from a remote device, the loopback will be dropped if you choose **clr**.

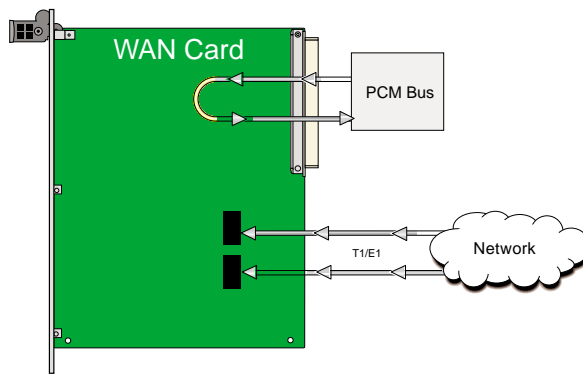

Figure 9-17.DS0 Time Slot Loopback

LB ADDR

The Loopback Address setting, when used in conjunction with the Channel Loopback setting, specifies which time slot will be looped back. Only one time slot may be looped back at a time for each WAN T1/E1 link. The options for T1 lines are **1** to **24**. For E1 lines, the options are **1** to **31**.

LB GEN

The Loopback Generate setting generates out-of-band diagnostic codes that are sent to the remote equipment. These codes are ANSI T1.403 compatible with T1 networks, and allow you to command a latching loopback at remote DS1 equipment. The options are **off**, **llb** (Line Loopback), **plb** (Payload Loopback), and **nlb** (Network Loopback). The **plb** setting is a loopback of the entire signal except the framing bits.

Selecting **off** generates a loopback deactivate command corresponding to the last activation command generated. e.g. if you send a **plb** command and then send an **off** command, the **off** command would be payload deactivate.

Note that the actual transmission of the command happens after you press ‘s’ for **Save**. If you have already sent one of the loopback activation commands, it is recommended that you send an **off** command before sending another loopback activation command. e.g. this set of selections **plb, off, llb, off** transmits the following commands: payload activate, payload deactivate, line activate, and line deactivate.

LB DET

This option allows the card to detect DS1 channel, and ANSI T1.403 loopbacks. When set to off, no T1 loopbacks can be detected. When set to on, T1 loopbacks will be detected and maintained until a loop down is detected. The with/time-out (w/to) is the same as on except that if no loop down is detected after 10 minutes, the loopback will self-terminate.

Currently WAN card with ESF Loopback is the only card that detects ANSI T1.403 loopback commands. The other WAN cards will only respond to “in-band” loopback codes. If the WAN is a loopback due to a command from a remote device, the loopback will be dropped if you switch to **off**.

ESF/NMS RP

This setting specifies the format in which performance statistics for the T1 link will be gathered and stored in the system. In ESF mode, these performance statistics are accessible to the carrier over the Facilities Data Link (FDL) as well as through the user interface. The options are **none**, **at&t**, **ansi**, **c-fdl**, **c-b7r** and **e-fdl**. The **at&t** option requires the statistics be gathered in accordance with AT&T Publication 54016 whereas the **ansi** option requires the ANSI T1.403 specification be used. Performance statistics are also available for D4 formatted T1 lines. See the “T1 Performance Monitoring” section later in this chapter for more detailed information on this topic.

The choice of **c-fdl** disables telco-side capability to access performance-monitoring information. The **c-fdl** option sends and receives network management information over the facility data link. The **c-b7r** option sends and receives the same information over time slot 24 on the T1 WAN link highlighted. The **e-fdl** option sends and receives T1 ESF-encapsulated network management information over the FDL.

EER THRHD

The Excessive Error Rate Threshold selects the error rate, which an alarm is declared. This setting interacts with the EER setting in the Alarm Filters of the system. The options are **10e-4** through **10e-9**, or **none**.

RDNT RULES

The selection of Redundancy Rules will define the method of determining what event will trigger a WAN port to switch to its redundant mate. The options are **none**, **OOS**, and **CGA**.

GROUP

The Group setting identifies a method of link-fail alarm propagation from upstream trunks to downstream tributaries when the system is configured for alarm transcoding.

The selection of a group is a two-step process. After identifying the group number (**1** to **4**), select the secondary group (**A** [child group], **B** [child group] or **C** [parent group]).

Figure 9-18 shows two system units with "parent-child" groupings. The child groups are designated as "A" and "B." The parent groups are designated "C".

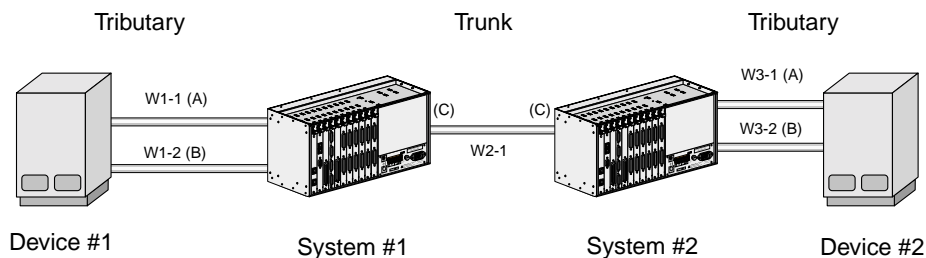

Figure 9-18.Using WAN Groups

The WAN links between the Device and the System Unit (A, B, A1, and B1) are called *tributaries*. The WAN link between the two SYS Units (C and C1) is referred to as a *trunk*.

In the normal condition (no WAN groups selected), a failure on any of the tributaries supplying Device 1 would be reported at SYS 1 and Device 1 only. A failure of the trunk from C to C1 would be reported at SYS 1 and 2 only.

When Groups are created at both system units, a trunk failure (C to C1) will inform all of the associated tributaries (A and B, A1 and B1) of that condition.

When groups are used in conjunction with the Network Management option (mentioned earlier) and the AIS/ALM is set to **tcodr**, a failure of any of the tributaries will propagate the failure through the trunk to the associated tributary at the other end (A to A1 or B to B1).

The following notification procedure is followed:

1. A Loss of Signal, Loss of Frame, Error Rate Exceeded, or AIS failure of the transmit leg of W1-1(A) occurs between Device 1 and SYS 1.

2. SYS 1 detects the failure on the receive leg and declares an alarm for W1-1(A).
3. SYS 1 sets the A Bit (Yellow Alarm) in the transmit leg of W1-1(A). Device 1 detects this condition and knows not to use W1-1(A).
4. SYS 1(C) sends an alarm message to SYS 2 (C1), telling it that W1-1(A) is either in a CGA_RED or AIS alarm.
5. SYS 2 sets the transmit leg of W3-1(A1) into AIS (CGA_RED). Device 2 detects this condition and knows not to use W3-1(A1).

When the original failure is corrected, the alarm is also cleared for downstream tributaries.

9.4.2 E1 CEPT Settings

Figure 9-19 shows the WAN Card Main Screen for E1 operation. This example shows a WAN-U card with two E1 modules in system chassis slot W1.



Figure 9-19. WAN Card Main Screen for CEPT/HDSL

Table 9-6 summarizes the actions you can perform from this screen, and Table 9-7 lists the CEPT settings controlled on the screen along with their possible and default values.

Table 9-6. E1 HDSL Screen Actions

Action	Function
Save	Saves changes to settings.
Undo	Returns all settings to the last saved state.
Refresh	Updates certain time-related information fields that are not automatically updated (i.e., performance and test data).
Xcon	Shows the time slot cross-connect map for each WAN port.
Perf	Brings up the Performance Data Screen. See the Performance Data section of this chapter.
Farstat	Shows the far-end network register data.
Test	Initiates and monitors testing of all WAN card ports. Refer to the Test section of this chapter.
sWitch	Allows you to switch WAN port operations to the redundant (WAN-R) card.
Hdsl	Brings up the HDSL Screen described later in this chapter. This command is shown only for a WAN-U card.
Main	Returns to the System Main Screen. If changes are made to settings and not saved, you will be prompted to save or abandon your changes.

Table 9-7. E1 Screen Option Settings and Defaults

Parameter	User Options	Notes	Default
STATE	stdby actv		stdby
MODE	xcon		xcon
FRAME	crc d-frm		crc
TS16	cas ccs nos		cas
EVEN BIT	norm inv		norm
AIS/ALM	none tcodr	1	none
LINE LB	off on		off
LOCAL LB	off on		off
CH LB	off clr		off
LB ADDR	01-31 (user-selectable)	2	01
LB GEN	off llb plb nlb		off
COM/NMS RP	none c-sa4 c-br7 e-sa4 (c-fdl)	3	none
EER THRHD	10e-4 through 10e-9 none		10e-4
RDNT RULES	n/a none OOS CGA	4	none
GROUP	none 1 2 3 4	5	none

Notes:

1. AIS/ALM will show **none** until the GROUP is selected.
2. The up and down arrow keys are used to scroll through the loopback address values.
3. The Farstat registers will not work properly for E1 operations unless the **c-sa4** option is selected for the COM/NMS RP parameter.
4. If there is no redundant WAN card in the appropriate slot, the only option that will appear is **n/a**.
5. Selection of GROUP is a two-step process. After identifying the group number (1-4), the user must select the secondary group (A, B or C).

STATE

In the standby state, the WAN port is electrically disconnected from the external network. Set State setting to **stdby** (standby) when setting up your WAN links, then changes it to **actv** (active) when starting normal operations.

MODE

In cross-connect systems, Mode automatically defaults to **xcon**.

FRAME

The Frame setting toggles the frame type from **crc** (Cyclic Redundancy Check, 4th level) to **d-frm** (Double Frame).

TS 16

The TS 16 setting changes the signaling usage of slot 16 for **cas** (Channel Associated Signaling), **ccs** (Common Channel Signaling) or **nos** (No Signaling). In the first two options, time slot 16 is used to carry signaling information for all channels on the E1. If **nos** is selected, then time slot 16 becomes available for user data.

EVEN BIT

Setting the Even Bit parameter for **inv** will cause the system to invert every even bit in every DS0 time slot. This setting should only be used if the entire E1 stream is composed of PCM voice, to ensure minimum-ones density.

AIS/ALM

The AIS/ALM (Alarm Indication Signal/Alarm) setting, allows the user to specify the type of “keep-alive” signal that the system will generate on one E1 should the other fail. After GROUP is selected, the two options for this setting are **none** and **tcodr** (for transcoder operations).

LINE LB

The Line Loopback setting controls looping of the full E1 line back to the network. When **on**, this setting allows end-to-end testing of the line.

LOCAL LB

The Loopback setting controls looping of the full E1 line back to the PCM bus. The options are **off** and **on**. When **on**, this setting allows testing of local equipment. The system generates a "Keep Alive–Type 1" pattern on the E1 line.

CH LB

The Channel Loopback setting allows you to place individual DS0 channels in loopback toward the PCM bus. A channel loopback loops a single DS0 channel and cannot be used to loop multiple DS0s or a portion of a DS0. Refer to user cards for other loopback options, which may allow you to loop part of a channel or multiple channels. The options are **on** and **off**.

LB ADDR

The Loopback Address setting, in conjunction with the Channel Loopback setting, specifies which channel is to be looped back. Only one channel may be looped back at any one time for each E1 link. The valid selections for E1 lines are **1-31**. Do not loop time slot 16 unless the E1 interface is in no signaling (**nos**) mode.

LB GEN

The Loopback Generate setting generates out-band diagnostic codes that are sent to the remote equipment. These codes are compatible with DDS networks and allow you to command a latching loopback at remote DDS equipment. The options are **off**, **llb** (Line Loopback), **plb** (Payload Loopback) and **nlb** (Network Loopback).

Selecting **off** generates a loopback deactivate command corresponding to the last activation command generated. e.g. if you send a **plb** command and then send an **off** command, the **off** command would be payload deactivate. Note that the actual transmission of the command happens after you press 's' for **Save**. If you have already sent one of the loopback activation commands, it is recommended that you send an **off** command before sending another loopback activation command. e.g. this set of selections **plb, off, llb, off** transmits the following commands: payload activate, payload deactivate, line activate, and line deactivate.

COM/NMS RP

The Communications/Network Management System Report setting tells the system where to send TCP/IP packets from the NMS configuration selected on the Interface card. The options are **none** (no NMS), **c-sa4** (use SA4 channel for NMS information), **c-b7r** (send NMS information to a B7R card on time slot 31), and **e-sa4** (send NMS information in a proprietary ESF format via the SA4 channel to a NTU).

EER THRHD

The Excessive Error Rate Threshold selects the error rate, which an alarm is declared. This setting interacts with the EER setting in the Alarm Filters of your system. The options are **10e-4** through **10e-9**, or **none**.

RDNT RULES

The selection of Redundancy Rules will define the method of determining what event will trigger a WAN port to switch to its redundant mate. The options are **none**, **OOS**, or **CGA**. See Chapter 3-C for more information on redundant WAN card operations. If there is no redundant WAN card in the appropriate slot, the only option that will appear is **n/a**.

GROUP

The Group setting identifies a method of link-fail alarm propagation from upstream trunks to downstream tributaries. Selection of group is a two-step process. After identifying the group number (1-4), the user must select the secondary group (A [child group], B [child group], or C [parent group]). The group setting is normally used for transcoder applications. See the groups diagram and discussion earlier in this chapter.

9.4.3 Cross-Connect (XCON)

The Cross-Connect (**Xcon**) command in the Main WAN screen allows you to view the time slot or DS0 assignments that have been set up in the system. Highlight the WANs on the card and press the “**x**” (**Xcon**) to select Cross-Connect. Either an E1 screen (Figure 9-20) or a T1 screen (Figure 9-21) will appear, depending upon the WAN highlighted. This is a display-only screen. Time slot and cross-connect configuration are discussed in the System Operations chapter of this manual.

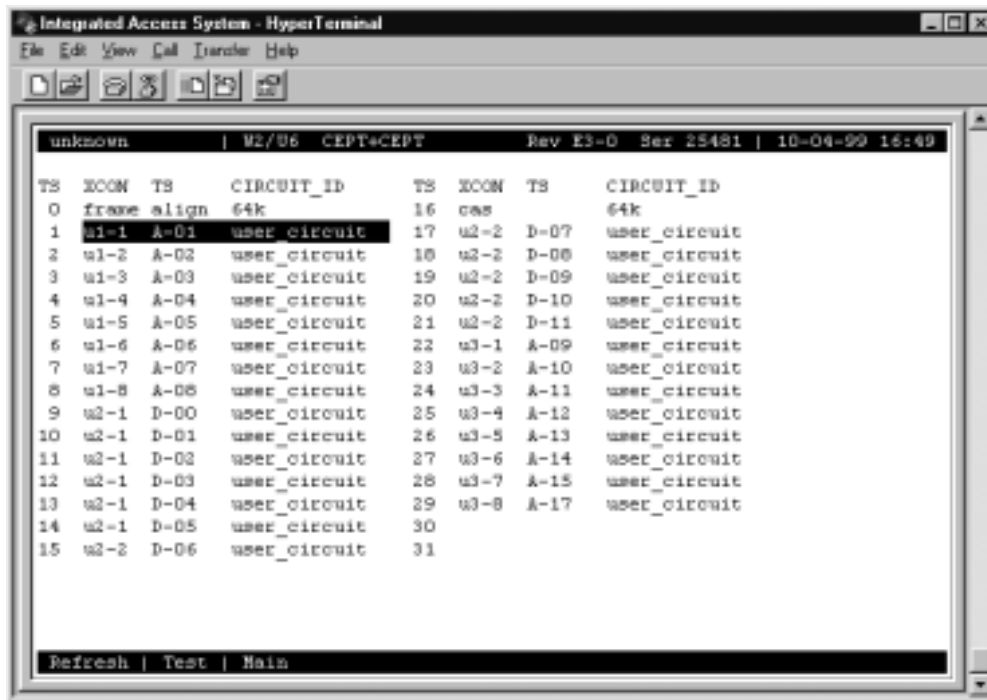

TS	XCON	TS	CIRCUIT_ID	TS	XCON	TS	CIRCUIT_ID
0	frame align		64k	16	cas		64k
1	u1-1	A-01	user_circuit	17	u2-2	D-07	user_circuit
2	u1-2	A-02	user_circuit	18	u2-2	D-08	user_circuit
3	u1-3	A-03	user_circuit	19	u2-2	D-09	user_circuit
4	u1-4	A-04	user_circuit	20	u2-2	D-10	user_circuit
5	u1-5	A-05	user_circuit	21	u2-2	D-11	user_circuit
6	u1-6	A-06	user_circuit	22	u3-1	A-09	user_circuit
7	u1-7	A-07	user_circuit	23	u3-2	A-10	user_circuit
8	u1-8	A-08	user_circuit	24	u3-3	A-11	user_circuit
9	u2-1	D-00	user_circuit	25	u3-4	A-12	user_circuit
10	u2-1	D-01	user_circuit	26	u3-5	A-13	user_circuit
11	u2-1	D-02	user_circuit	27	u3-6	A-14	user_circuit
12	u2-1	D-03	user_circuit	28	u3-7	A-15	user_circuit
13	u2-1	D-04	user_circuit	29	u3-8	A-17	user_circuit
14	u2-1	D-05	user_circuit	30			
15	u2-2	D-06	user_circuit	31			

Figure 9-20.E1 Cross-Connect Screen (display only)

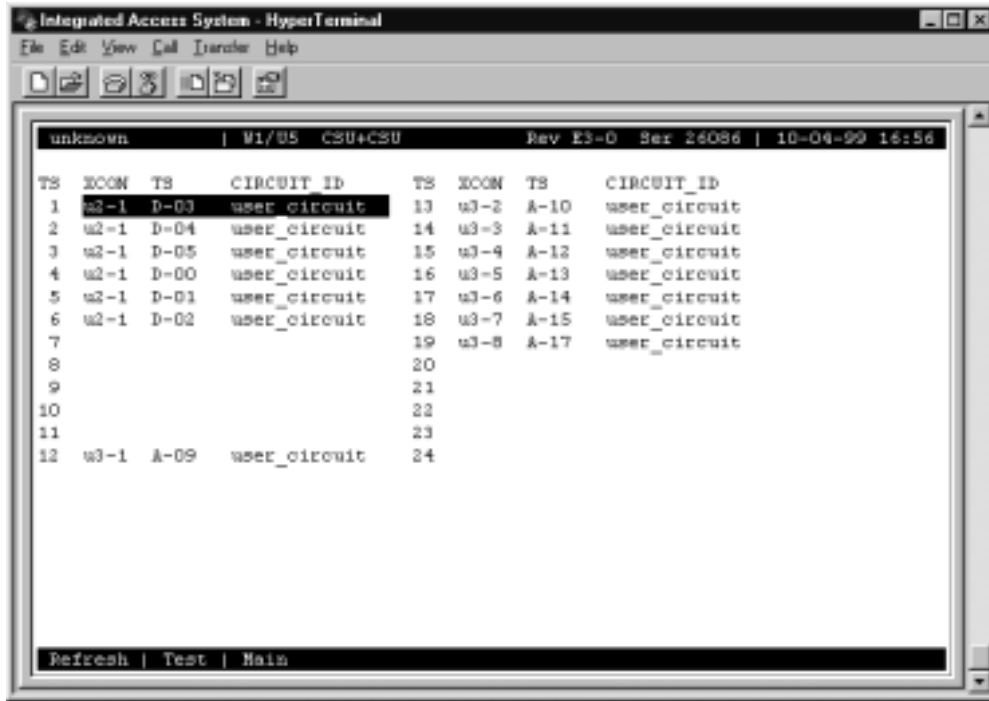

Figure 9-21.T1 WAN Cross-Connect Screen (display only)

9.4.4 Performance Data

All WAN cards gather performance data. The performance data for a T1 or E1 line is viewed by typing “**p**” in the WAN Card Main Screen, to invoke the **Perf** command. Performance data is accumulated for 15-minute increments that include the current period and the previous 96 periods (24 hours), which are accessed via the **pgUp** and **pgDn** commands of the Main Screen.

In the T1 environment, an error is defined as any CRC-6, Controlled Slip, or Out of Frame (OOF) error for **ESF** framing, and any Bipolar Violation (BPV), Controlled Slip, or OOF error for the D4 format. In an E1 environment, an error is defined as any CRC-4 error, Controlled Slip, or OOF error.

Figure 9-22 shows a typical T1 Performance Data Screen. The E1 screen is similar except for the actions on its bottom line, where **uSerregs** and **Networkregs** commands are not provided. The performance statistics are gathered and displayed in 15-minute intervals. Lines in each of the columns represent periods when no seconds have accumulated.

In the AT&T mode, two sets of registers accumulate performance data for T1 WAN links. The user registers and network registers are driven by the same errored events. However, they can be cleared separately. You can view both the user and network registers, but you can only clear the user registers. The network only has access to the network registers, and can only clear those registers. The ANSI and E1 WAN links have only one set of registers.

```

Integrated Access System - HyperTerminal
File Edit View Call Transfer Help
[Icons]
unknown | W1/05 CSU+08X Rev E3-0 Ser 26086 | 10-04-99 16:59
Unit 1 PERFORMANCE USER REGISTERS Sec. 015 of 900
      ES   UAS   SES   BES   LOFC  SLIP  DN   STATUS
CUR    1    0    1    0    0    1    1    .NT..B.
01     ----  ----  ----  ----  ----  ----  ----  .....
02     ----  ----  ----  ----  ----  ----  ----  .....
03     ----  ----  ----  ----  ----  ----  ----  .....
04     ----  ----  ----  ----  ----  ----  ----  .....
05     ----  ----  ----  ----  ----  ----  ----  .....
06     ----  ----  ----  ----  ----  ----  ----  .....
07     ----  ----  ----  ----  ----  ----  ----  .....
08     ----  ----  ----  ----  ----  ----  ----  .....
09     ----  ----  ----  ----  ----  ----  ----  .....
10     ----  ----  ----  ----  ----  ----  ----  .....
11     ----  ----  ----  ----  ----  ----  ----  .....
12     ----  ----  ----  ----  ----  ----  ----  .....
TOTAL  0    0    0    0    0    0    0    .....
STATUS: Y=YEL N=NOS T=Test L=LOS O=OOS B=BPV E=ERR
Refresh | pgUp | pgDn | uSerregs | Networkregs | Clearregs | Main

```

Figure 9-22. Typical Performance Data Screen

Table 9-8 lists the actions available from the Performance Data Screen.

Table 9-8. Performance Data Screen Actions

Action	Function
Refresh	Because statistics are not calculated in real time, the Refresh command must be used to update the screen with new information.
pgUp	Pages through the performance statistics for the current 15 minute period and periods 96-1.
pgDn	Pages through the performance statistics for the current 15 minute period and periods 1-96.
uSerregs	Allows you to view the User Registers. Not shown for E1 operations because it is the only set of registers for that mode.
Networkregs	Allows you to view the Network Registers. When you are viewing the network registers, the Clear Registers option disappears. (This action is not available in D4 mode or E1 operations.)
Clearregs	Clears the User Registers. Network statistics remain the same.
Main	Returns to the WAN Card Main Screen.

ES

An Errored Second (ES) is a second with one or more CRC-6 (ESF), BPV (D4/D-Frame), or CRC-4 (E1) errors, one or more Out-Of-Frame (OOF) errors, or one or more Controlled Slips.

UAS

An Unavailable Second (UAS) is any second during which service is unavailable. An unavailable signal state is declared after ten consecutive Severely Errored Seconds (SESs) are logged. An unavailable state is cleared after ten consecutive non-Severely Errored Seconds are logged. Unavailable Seconds are also accumulated if the card has an out-of-service (OOS) condition.

SES

A Severely Errored Second (SES) is any second with 320 or more CRC-6 (T1 ESF), BPV (T1 D4/D-frame), or CRC-4 (E1) errors. Or, an SES can be any second with one or more Out-Of-Frame (OOF) errors.

BES

A Bursty Errored Second (BES) is any second with more than one and fewer than 320 CRC-6 (ESF), BPV (D4/D-frame), or CRC-4 (E1) errors.

LOFC

The Loss of Frame Count (LOFC) is the number of times a Loss Of Frame (LOF) is declared. An LOF is declared after 2.5 seconds of a continuous Loss Of Synchronization (LOS) or Out-Of-Frame (OOF) condition. The LOF is cleared after no more than 15 consecutive seconds without another LOS or OOF.

SLIP

A Slipped Second is any second that contains one or more Controlled Slips. A Controlled Slip is the deletion or replication of a T1 or E1 frame by the receiving equipment.

DM

A Degraded Minute (DM) is any minute during the reporting period that has an error rate greater than 10^{-6} as described in ITU-T G.821. The count for this field is from 1 to 15, rather than 1 to 900 for the other fields.

STATUS

If one of the described errors occurs during any of the 15-minute intervals, the status column for that period would display the code for that error. The codes are displayed at the bottom of the screen. The values are **Y** (Yellow Alarm received), **N** (No Signal), **T** (Test Mode - line loopback, local loopback, payload loopback, or standby), **L** (Loss of Synchronization – 2 out of 4 frame bits in error), **O** (Out of Service), **B** (Bipolar Violation), and **E** (Excessive Error Rate).

9.4.5 Far-End Performance Data

The Far-End Performance Data Screen is similar to the Performance Data Screen. The same statistics are collected in a slightly different manner. Figure 9-23 shows a typical display of far-end network register data in the AT&T mode. To view the far-end performance data, press “**F**” (**Farstat** command) in the WAN Card Main Screen.

When **Farstat** is selected in the T1 AT&T mode, an FDL message is sent to the far end, requesting the network register data from there. This data is displayed on the local terminal. There will be a slight time delay in the data display.

When **Farstat** is selected in the ANSI T1.403 mode, the far end generates one-second performance reports and sends them to the local system, where they are then stored.

To view E1 far-end statistics, you must select **c-sa4** as the COM/NMS RP setting.

```

unknown | W2 H E1+H E1 Rev E3-0 Ser 26086 | 09-28-99 14:26
Unit 1 AT&T FAREND STATISTICS NETWORK REGISTERS Sec. 000 of 900 008 W2
ES UAS SES RES LOFC SLIP
CUR *****
01 *****
02 *****
03 *****
04 *****
05 *****
06 *****
07 *****
08 *****
09 *****
10 *****
11 *****
12 *****
TOTAL *****
Refresh | Clear | pgUp | pgDn | Main
Connected 35346 VT100 9600 8N-1 SCROLL CAPS NUM Capture Print echo

```

Figure 9-23. Typical Far-End Performance Data Screen



Note: Astericks (*) are displayed when performance data is unavailable.

Press “c” (Clear command) from the bottom line of this screen to send a FDL message to the far end and also clear the local display. The following message will now appear:

“Ok to clear performance (y/n)?”

Press “y” to clear the statistics, or “n” to leave the screen contents intact. To view the far-end information again, press “r” (restore) to send an FDL message and refresh the screen. Table 9-9 lists the actions available from the above screen.

Table 9-9. Far-End Performance Data Screen Actions

Action	Function
Refresh	Because data is not calculated in real time, the Refresh command must be used to update the screen with new information.
Clear	Clears the Far-End Network Registers display on the local terminal.
PgUp	Pages through the performance statistics for the current 15-minute period and periods 96-1.
PgDn	Pages through the performance statistics for the current 15-minute period and periods 1-96.
Main	Returns to the WAN Card Main Screen.

ES

An Errored Second (ES) is a second with one or more CRC-6 (ESF) or BPV (D4/D-Frame) errors, one or more OOFs, or one or more Controlled Slips.

UAS

An Unavailable Second (UAS) is any second during which service is unavailable. An unavailable signal state is declared after ten consecutive Severely Errored Seconds (SESs) are logged. An unavailable state is cleared after ten consecutive non-Severely Errored Seconds are logged. Unavailable Seconds are also accumulated if the card has an out-of-service (OOS) condition.

SES

A Severely Errored Second (SES) is any second with 320 or more CRC-6 (ESF) or BPV (D4/D-Frame) errors, or one or more OOF errors.

BES

A Bursty Errored Second (BES) is any second with more than one and fewer than 320 CRC-6 (ESF) or BPV (D4/D-Frame) errors.

LOFC

The Loss of Frame Count (LOFC) is the accumulation of the number of times a Loss Of Frame (LOF) is declared. An LOF is declared after 2.5 seconds of continuous Loss Of Synchronization (LOS) or OOF condition. An LOF is cleared after no more than fifteen consecutive seconds without an LOS or OOF condition.

SLIP

A Slipped Second is any second containing one or more Controlled Slips. A Controlled Slip is the deletion or replication of a DS1 frame by the receiving equipment.

9.4.6 Test Screen

Pressing “t” (Test command) in the WAN Card Main Screen brings up the screen shown in Figure 9-24. From this screen, you can create test situations between WAN cards or between a single WAN card and data test equipment at a remote site. Table 9-10 lists the actions you can perform from the bottom line of this screen. Table 9-11 lists the settings controlled on this screen along with their possible values.



Figure 9-24. Typical WAN Card Test Screen

Table 9-10. Test Screen Actions

Action	Function
Save	Saves changes to settings.
Undo	Returns all settings to the last saved state.
Refresh	Updates certain time-related information fields that are not automatically updated (i.e., performance and test data).
Insert Err	Allows you to manually insert a single bit error into the data signal. This does not cause a CRC error.
Clear	Clears the Test Screen and resets all counters to zero.
Main	Returns to the WAN Card Main Screen. If changes are made to settings and not saved, you will be prompted to save or abandon those changes.

Table 9-11. WAN Card Test Screen Options

Parameter	User Options	Notes	Default
BERT	off mark space 1:1 1:7 3:24 qrss lp-up lp-dn	1	off
SYNC	information only—no user options		
BE	information only—no user options		
ES	information only—no user options		
SES	information only—no user options		
CSES	information only—no user options		
OSS	information only—no user options		
BER	information only—no user options		
ELAP	information only—no user options		
LB STATE	information only—no user options		

Notes:

1. The **lp-up** (loop-up) and **lp-dn** (loop down) codes are not supported for CEPT or HDSL WANs. Turning any of these tests on or off will cause a temporary interruption of data transmission on the DS0 time slots as well as on the FDL bit of the corresponding port.

BERT

The Bit Error Rate Tester (BERT) sends a data pattern and measures the bit error rate (BER) on the selected WAN port. The patterns that can be selected are **off**, **mark** (all ones), **space** (all zeros), **1:1** (0101), **1:7** (0100 0000), **3:24** (this pattern requires 3 bytes to display), **qrss** (quasi-random signal source), **lp-up** (which sends a T1 loop-up code to the remote end) and **lp-dn** (which sends a loop-down code to the remote end). The last two options are not available for WAN cards with CEPT or HDSL modules.

SYNC

The Synchronization (SYNC) field tells you if the integrated BERT has achieved synchronization either with itself via a remote loopback or with the remote test equipment. Since this is an information-only field, there are no user-selectable parameters.

BE

The Bit Error (BE) field shows the total number of bit errors logged. Since this is an information-only field, there are no user-selectable parameters.

ES

The Errored Seconds (ES) field shows the total number of seconds in which any errors were detected. Since this is an information-only field, there are no user-selectable parameters.

SES

The Severely Errored Seconds (SES) field shows the total number of seconds in which the bit error rate exceeded one bit per thousand (1×10^{-3}). Since this is an information-only field, there are no user-selectable parameters.

CSES

The Consecutive Severely Errored Seconds (CSES) field is triggered by the occurrence of ten consecutive Severely Errored Seconds. Once triggered, the CSES field will increment (by one) for each elapsed second until the system logs ten consecutive non-Severely Errored Seconds. Since this is an information-only field, there are no user-selectable parameters.

OSS

The Out of Synchronization Seconds (OSS) field shows the number of seconds that the WAN BERT has been out of synchronization. Since this is an information-only field, there are no user-selectable parameters.

BER

The Bit Error Rate (BER) field shows the rate at which errors are being logged. The system calculates BER by dividing the number of bit errors (BE) by the total number of bits transmitted during the test. Since this is an information-only field, there are no user-selectable parameters.

ELAP

The Elapsed time setting shows the running tally of the total number of seconds during the test. Since this is an information-only field, there are no user-selectable parameters.

LB STATE

The Loopback State setting changes when a WAN unit is both present and operational. This includes loopbacks caused by commands from remote devices as well as loopbacks caused by local settings. The field will show **plb** (payload loopback) when the entire signal, *excluding the framing bit*, is looped back. The field will show **llb** (line loopback) when the entire signal is looped back. It will show **none** if the WAN port is not in loopback.

9.5 WAN Card Error Messages

Refer to Appendix B in the System Reference Guide for further information on Error Messages regarding this card.

9.6 WAN Card Troubleshooting

The WAN card (or a T1 or E1 port on it) may be faulty if a CGA-Red alarm is in progress on either port of the card. This alarm occurs if the incoming network signal is lost, or if the WAN port is out of frame with that signal. To isolate the trouble, proceed as follows:

1. See if similar alarms are also present on any other T1/E1 lines and WAN cards in the system. If so, the trouble may be with the Interface card, which connects the T1 and E1 signals from the WAN cards to the external network. If the trouble is only on one T1 or E1 line connected to the WAN card, continue with step 2.
2. Perform a local T1 or E1 signal loopback toward the CPE, and see if the CGA alarm clears after about 10 to 30 seconds. If it does, the WAN card is good; go to step 3. Otherwise, go to step 4.
3. Check the local network equipment receiver, cabling to the Interface card at the local system, and the far-end system or network transmitter.
4. Replace the WAN card with an identical WAN card. Be sure to install the same types of plug-in modules and that the jumpers on the cards are identical on the new WAN card before plugging it in.
5. If the WAN card is determined to be faulty, replace it and return the faulty unit for repair to the location specified by your distributor.

9.7 WAN Card Specifications

WAN Cards (Models 801060, 801065, 801070, 801460 and 801470 T1/E1)

Physical

Model	Number of Ports	Number of Cards	Physical I/F	Electrical I/F
801060, 801065, 801460, 801560	2	1 to 4	Through 893x70 I/F card	81130 (T1-DSX/E1-CEPT) 81200 (T1-CSU) - 1 per port
801070, 801470	2	1 to 4	Through 893x70 I/F card	On-board

Performance and Test Options

Loopbacks	Line, Local Channel, Loopback Generation and Detection, ESF
T1	FDL in accordance with AT&T 54016 or ANSI T1.403
E1	National Bit Supporting (G.704)

T1/DSX Interface

Bit Rate and Tolerance	1.544Kbps + 32 ppm
No. of T1 WAN Links per module	1
Max. No. per WAN card	2
Electrical Interface	Per ANSI T1.102/T1.403, DSX-1 100 ^{1/2} balanced
Transmission Range	Software Selectable: 0, 133, 266, 499, 533 or 655 ft. (200 m), csu (csu - allows connection to the equipment side of a co-located external CSU over a short-distance, four-wire cable)
Line Coding	Software Selectable AMI or B8ZS
Frame Format	Software Selectable - D4, ESF, SLC 96, Subscriber Loop Carrier D4
D4 Framing	Normal Superframe
ESF Framing	Extended Superframe
Impedance	100 OHMs
Subscriber Loop Carrier 96	As per TR-TSY-000008 Mode 1 Supports logical shelf A, logical shelf B or logical shelf group AB only Supports POTS, CLASS services, CENTREX services, Loop and Ground Start FXS and FX trunks and DID circuits Does not support Multi-Party or Coin Phone lines
Subscriber Loop Carrier D4	Supports SP/UVG signaling Supports shelf group B only
Voice Channel Signaling	AT&T PUB 43801, AT&T 62411, ITU-T Q.421, Q.422 using Robbed-bit method
Error Detection	

Frame Format	Error Scheme
ESF	CRC-6, Controlled Slip, Out of Frame
D4, SLC96, SLCD4	BiPolar Violation, Controlled Slip, Out of Frame

Alarm Indication	As per Bellcore TR-TSY-000191
SLIP Limit	Software Selectable: 126 bits or 138 bits
Equalization	Software Selectable: Adjustable line build out (LBO) settings for 133, 266, 399, 533, 655 ft, csu (CSU option provides connection to equipment side of co-located external CSU)
Power Levels	Complies with ANSI T1.403 and ITU-T G.703
Output Jitter	Complies with ITU-T G.824
Input Jitter and Wander	Complies with ITU-T G.824

CSU Interface

Bit Rate and Tolerance	1.544 Mbps + 32 ppm
No. of T1 WAN Links per module	1
Max. No. per WAN card	2
Electrical Interface	Per ANSI T1.102/T1.403, DSX-1 100 ¹ / ₂ balanced
Transmission Range	Software Selectable - 0 dB, 7.5 dB, 15 dB 3000 feet to 6000 feet with 40 dB cable loss (@ 5000 ft. or 1500 m) Actual range depends on cable characteristics although software selectable ranges of 0 dB, 7.5 dB and 15 dB are provided. (0 - allows connection to the network side of a co-located external CSU over a short-distance, four-wire cable)
Line Coding	Software Selectable AMI or B8ZS
Frame Format	Software Selectable - D4, ESF, SLC96, Subscriber Loop Carrier D4
D4 Framing	Normal Superframe
ESF Framing	Extended Superframe
Subscriber Loop Carrier 96	As per TR-TSY-000008 Mode 1 Supports logical shelf A, logical shelf B or logical shelf group AB only Supports POTS, CLASS services, CENTREX services, Loop and Ground Start FXS and FX trunks and DID circuits Does not support Multi-Party or Coin Phone lines
Subscriber Loop Carrier D4	Supports SP/UVG signaling Supports shelf group B only
Voice Channel Signaling	AT&T PUB 43801, AT&T 62411, ITU-T Q.421, Q.422 using Robbed-bit method

Error Detection

Frame Format	Error Scheme
ESF	CRC-6, Controlled Slip, Out of Frame
D4, SLC96, SLCD4	BiPolar Violation, Controlled Slip, Out of Frame

Alarm Indication	As per Bellcore TR-TSY-000191
SLIP Limit	Software Selectable: 126 bits or 138 bits
Equalization	Software Selectable with settings for 0, 7.5 or 15.0 dB
Power Levels	Complies with ANSI T1.403 and ITU-T G.703
Output Jitter	Complies with ITU-T G.824
Input Jitter and Wander	Complies with ITU-T G.824

E1 Interface

Bit Rate and Tolerance	2.048 Mbps \pm 50 ppm									
No. of E1 WAN Links per module	1									
Max. No. per WAN card	2									
Electrical Interface	G.703 balanced 120 W or unbalanced 75 W Prior to Rev F0 - Jumper Selectable: 75 $\frac{1}{2}$ unbalanced or 120 $\frac{1}{2}$ balanced. Rev F0 and above - Jumper Selectable: 75 $\frac{1}{2}$ unbalanced or 120 $\frac{1}{2}$ balanced. (Balanced mode operation may be achieved via the 1183 or 1184 Distribution Panel).									
Transmission Range	2.0 km on 22 AWG									
Line Coding	High Density Bipolar of order 3 (HDB3)									
Frame Format	ITU-T G.704 - Double Frame or CRC-4 Multiframe Format									
Signaling	If voice signaling is required, it is transported in time slot 16 Software Selectable: cAS, CCS or none CAS Signaling Protocols: AT&T 43801, AT&T 62411, ITU-T Q.42									
Signaling Channels	ITU-T G.704 supporting ABCD signaling									
Error Detection	CRC-4, Controlled Slip, Out of Frame									
Alarm Indication	ITU-T G.732									
Pulse Shape	Per G.703 Figure 15 (1991)									
Pulse Amplitude	Per G.703 Table 6 (1991)									
	<table border="1"> <thead> <tr> <th></th> <th>75$\frac{1}{2}$ unbalanced</th> <th>120$\frac{1}{2}$ balanced</th> </tr> </thead> <tbody> <tr> <td>mark/pulse</td> <td>2.37 V</td> <td>3 V</td> </tr> <tr> <td>space/no pulse</td> <td>0 \pm 0.237</td> <td>0 \pm 0.3 V</td> </tr> </tbody> </table>		75 $\frac{1}{2}$ unbalanced	120 $\frac{1}{2}$ balanced	mark/pulse	2.37 V	3 V	space/no pulse	0 \pm 0.237	0 \pm 0.3 V
	75 $\frac{1}{2}$ unbalanced	120 $\frac{1}{2}$ balanced								
mark/pulse	2.37 V	3 V								
space/no pulse	0 \pm 0.237	0 \pm 0.3 V								
Nominal Pulse Width	244 ns									
Output Jitter	As per G.823									
Input Jitter and Wander	As per G.823									

Standards Compatibility

AT&T	TR43801 TR54016	Digital Channel Bank Requirements and Objectives Requirements for Interfacing Digital Terminal Equipment to Service Employing the Extended Superframe Format
Bellcore	TR62411 TR-TSY-000008	Accunet 1.5 Service, Description and Interface Specifications Digital Interface Between the SLC 96 Digital Loop Carrier System and a Local Digital Switch (Issue 2 08/87)
	TR-TSY-000191 GR-63-CORE Issue 1	Alarm Indication Signal, Requirements and Objectives Network Equipment-Building System (NEBS) Requirements: Physical Protection
ANSI	T1.101 T1.107 T1.403 T1.408	Synchronization Interface Standards for Digital Networks Digital Hierarchy - Formats Specifications ISDN, Network-to-Customer Installation -DS1 Metallic I/F ISDN Primary Rate
ITU-T	G.703 G.704 G.732 G.735	Physical/Electrical Characteristics of Hierarchical Digital I/F Synchronous Frame Structure Used At Primary and Secondary Hierarchical Levels Characteristics Of Primary PCM Multiplexed Equipment Operating at 2048 Kbit/sec. Characteristics Of Primary PCM Multiplexed Equipment Operating at 2048 Kbit/sec. and Offering Synchronous Digital Access at 384 Kbit/sec. and/or 64 Kbit/sec.

	G.736	Characteristics of A Synchronous Digital Multiplex Equipment at 2048 Kbits/sec.
	G.823	The Control of Jitter and Wander Within Digital Networks which are based on the 2048 Kbits/sec Hierarchy.
	G.824	The Control of Jitter and Wander Digital which are based on the 1544 Kbits/sec Hierarchy.
	Q.421	Digital line signaling code
	Q.422	Clauses for exchange line signaling equipment
ETSI	ETR 152	Reference: RTR/TM-03036 - Transmission and Multiplexing (TM); High bitrate Digital Subscriber Line (HDSL) transmission system on metallic local lines; HDSL core specification and applications for 2048 kbit/sec. based access digital sections including HDSL dual-duplex Carrierless Amplitude Phase Modulation - Edition 2 1995-06 - 158 Pages
UL/CSA	UL 1950 C22.2, No. 950	UL Standard for Safety of Information Technology Equipment Safety of information technology equipment including electrical business equipment.
CEN	EN 50 081-1	Electromagnetic compatibility generic emission Part 1 Residential, commercial and light industry.
	EN 50 082-1	Electromagnetic compatibility generic immunity standard Part 1 Residential, commercial and light industry.
	EN 60 950/A2	Safety of information technology equipment including electrical business equipment.

Chapter 10

Alarm Cards

10.1 Introduction

This chapter provides installation, configuration, and troubleshooting information for the Alarm card. The card is labeled as the ALR 4+4 on the faceplate ejector.

The Alarm card allow the system to report alarms to external alarm annunciators and other systems. Each card also receives alarms reported by external devices. Each card has switches for outbound alarms, and sensors that detect incoming alarms from the external equipment.

Only one Alarm card can reside in the Integrated Access System at a time. These cards are discussed below.

Each card has two alarm notification modes. The "Switch/Act On" (outbound) function allows you to report internal system alarms to external devices, such as buzzers, bells, and lights. The "Sensor/Trig On" (inbound) function allows you to receive external alarms through sensors on the card.

10.2 Alarm Card Descriptions

10.2.1 ALR 4+4 Card Description (840160)

The ALR 4+4 Card has four outbound alarm switches and four inbound alarm sensors. The outbound switches report internal alarms to external devices by triggering form-C relay contact closures (120 VAC, 0.5A). The inbound sensors report external alarms to the system. All external alarms reported by sensors are listed in the alarm history file.

An Integrated Access System with an ALR 4+4 Card can respond to four external alarms for control of environmental and security conditions, and also provide four internal alarms to outside alarm indicators. For example, a critical alarm can illuminate a red light at the office.

Each inbound alarm sensor has the capability of responding to one external condition. The alarms appear on the screen in the alarm section, showing the alarm as a SENSOR alarm and includes the slot number and sensor number of the condition (e.g., SENSOR U7-4).

The inbound alarm sensors can use either 12V or 48V. Both JP1 and JP2 jumpers should be set for the proper voltage. The inbound sensors are isolated from ground.

Each outbound "floating" relay has normally open contacts and normally closed contacts. It responds to major, critical, minor, and informational alarms, and activates an external device. Two relays are provided for each Alarm Card port. The relays are dual-pole, double-throw.

10.2.1.1 Card Jumper/Switch Settings

The US/Euro jumper pair on the ALR 4+4 card must be configured to the same setting as that of the chassis. The factory default setting for cards and chassis is **US** position.

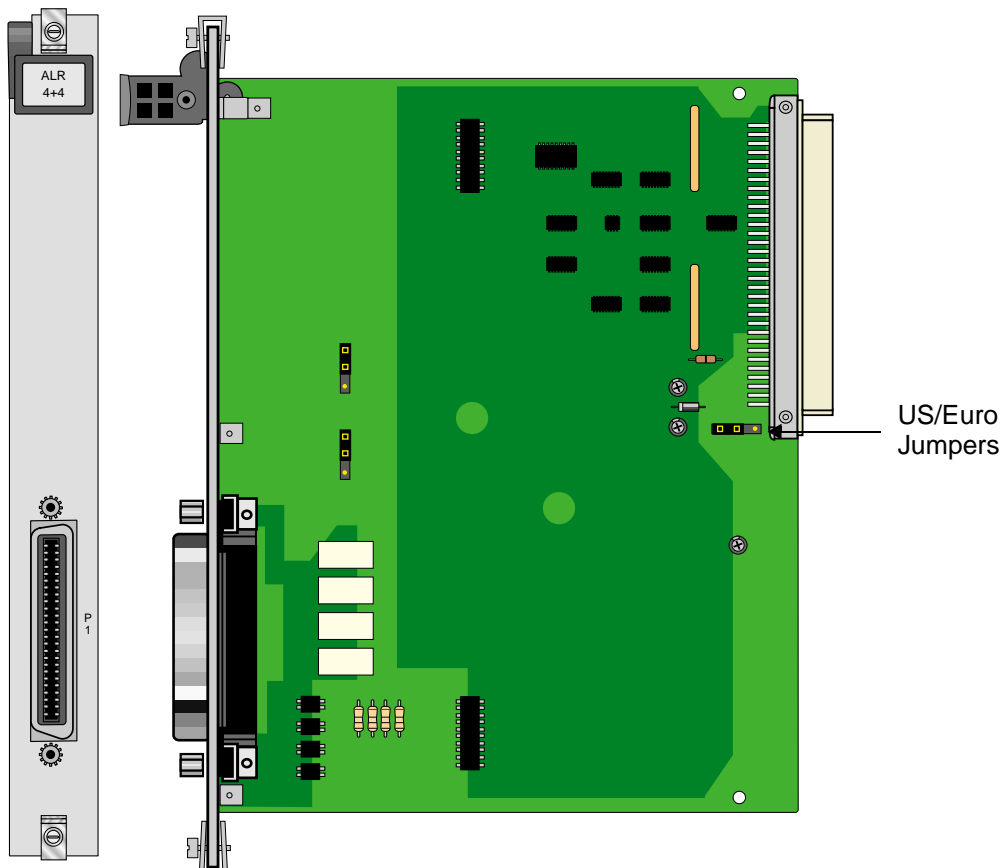

Figure 10-1.ALR 4+4 Card

10.2.1.2 Installing the Alarm Card

The Alarm card can be installed in any user card slot. These slots are U1 to U8 on the two-sided chassis and front-loading chassis with power supplies on top, and P1 to P4 or W1 to W4 on the front-loading chassis with power supplies on the side.

10.3 Alarm Card User Screens and Settings

10.3.1 Alarm Filter Screen Sensor Setting

First, make sure the master setting for all alarm sensors is set properly as the **SENSOR** variable in the Alarm Filter Screen. To set this variable, first select **Alarms** from the System Main Screen, then choose **Filters**. This will display a list of alarm filters, as shown in Figure 10-2.

In this menu, use the arrow keys to highlight the first column of the **SENSOR** line. Pressing <Enter> displays the options **ignore**, **log**, and **report**. The option chosen here will act as the highest-level option for all alarm card sensors. If this variable is set to **ignore**, *any alarm conditions on the alarm card will be ignored*, even if you set them up individually to **log** or **report**.

Likewise, if you set this variable to **log**, all sensors on the Alarm card that are set to anything other than **ignore** will be logged but not reported. For this reason, it is crucial that the **SENSOR** variable be set to **report** (see Figure 10-2).

Filter Name	Description	1	2	3
OOS	Out of Service	log	major	acc-off
NOS	No Signal	log	minor	acc-off
LOS	Loss of Sync	log	minor	acc-off
YEL	Yellow Alarm	log	minor	acc-off
AIS	Alarm Info Signal	log	minor	acc-off
CGA_RED	Carrier Group - Red	log	major	acc-off
CGA_YEL	Carrier Group - Yellow	log	major	acc-off
EER	Excessive Error Rate	ignore	minor	acc-off
SENSOR	Alarm card sensor	log	minor	acc-off
DCHAN	D-chan out of service	ignore	minor	acc-off
SWITCH	Switch to redundant card	report	major	acc-off
UCA	User card/port alarm	ignore	minor	acc-off
RESET	System reset	report	major	acc-off
ACO	Alarm Cut-Off	log	minor	n/a
SYNC	Clock Sync Alarm	ignore	minor	acc-off
EER-3	Error rate above 10e-3	ignore	minor	acc-off
PLC_OOF	DS3 PLCP Out of Framing	ignore	minor	acc-off
PLC_LOF	DS3 PLCP Loss of Frame	ignore	minor	acc-off
PLC_YEL	DS3 PLCP Yellow Alarm	ignore	minor	acc-off

Figure 10-2. Alarm Filter Screen

10.3.2 ALR 4+4 Card Main Screens

Figure 10-3 shows the ALR 4+4 Card Main Screen. To go to this screen, highlight the Alarm card in the System Main Screen and press <Enter>.



Figure 10-3. ALR 4+4 Card Main Screen

The bottom highlighted line of the screen shows several actions that you can perform from this screen. To perform an action, simply press the uppercase letter on your keyboard that corresponds to the desired action. Table 10-1 lists these actions, and Table 10-2 summarizes the card configuration option settings and default values. Each parameter is also described in the following paragraphs.

Table 10-1. ALR 4+4 Card Main Screen Actions

Action	Function
Save	Saves changes to settings.
Undo	Returns all settings to the last saved state.
Refresh	Updates certain time-related information fields that are not automatically updated on screen (i.e., alarm data).
Main	Returns to the System Main Screen. If changes are made to settings and not saved, you will be prompted to save or lose changes.

Table 10-2. ALR 4+4 Card Option Settings and Defaults

Parameter	User Options	Default
SWITCH	stdby actv	stdby
ACT ON	minor major any	minor
SENSOR	stdby actv	stdby
TRIG ON	close open	close

SWITCH

The Switch setting indicates that the outbound alarm switch is **actv** (on) or **stdby** (off).

ACT ON

The Act On parameter defines the type of system alarm that will cause the switch to trigger. Program each alarm switch to trigger on **minor** (information and minor) alarms, **major** (major and critical) alarms, or **any** alarm message.

SENSOR

The Sensor setting indicates the inbound alarm sensor is **actv** (on) or **stdby** (off).

TRIG ON

The Trigger On parameter defines if the sensor should report an external alarm upon sensing the opening (**open**) or the closure (**close**) of the C-form contact to which it is connected.

MAJOR =

The Major = accumulation register shows the current number of reported alarms designated as Major or Critical.

MINOR =

The Minor = accumulation register shows the current number of reported alarms designated as Minor or Informational.

10.4 Alarm Card Error Messages

Refer to Appendix B in the System Reference Guide for further information on Error Messages regarding this card.

10.5 Alarm Card Troubleshooting

Alarm card problems could indicate a number of possible causes. Typically, a problem is indicated by the loss of an incoming alarm signal on a sensor port or the lack of a contact closure/open in response to an internal alarm. Steps designed to isolate the source of the problem and return the card to normal operation are detailed below. When troubleshooting Alarm card problems, you should follow this general sequence:

1. Verify that the US/EUR jumper is correctly positioned on the Alarm card to match the US/EUR jumper on the chassis. Also verify that the voltage level selected is the same on JP1 and JP2.
2. Verify that the Alarm card sensor filter (SENSOR) is set to either **log** or **report** in the Alarm Filters Menu. This menu is accessed by selecting "Alarms" from the Main Screen (not the Alarm Card Screen), and then selecting "Filters." Column 1 lists the filter setting (ignore, log, or report). You can change the filter setting by highlighting the item you wish to change and pressing the <Enter> key. Use the arrow keys to highlight a new filter setting and press the <Enter> key again. If you are satisfied with your selections, remember to "Save" before exiting the screen. If you make any changes and then attempt to exit the screen without saving, you will be prompted "Ok to lose changes (y/n)?" You must select "y" or "n". If you select "y", any changes will be lost and all selections will revert to the last saved state.
3. On the Alarm card menu, verify that the switch/sensor in question is set to active (**actv**). If set correctly and the problem is with a switch (contact), go to step 4. If the problem is with a sensor, go to step 6.
4. Verify that the amphenol cable is connected correctly to the Alarm card. At a cross-connection point between the Alarm card and the external "scan point", open the circuit under test. Connect a Volt-Ohmmeter set to read resistance across the Alarm card contact in question. If no alarm of the type (Major, Minor or Any) that the contact is programmed to act upon is present, and it is a normally open (NO) contact, the meter will read infinite resistance. If you are testing a normally closed (NC) contact, the meter will read 0 ohms resistance.
5. Generate an alarm of the type (Major, Minor or Any) that the contact is programmed to act upon. The Volt-Ohmmeter should detect a resistance change from 0 to infinite or infinite to 0, depending on the type of contact (NO or NC). If no change is detected, the switch port may be defective.

6. Verify the amphenol cable is connected correctly to the Alarm card. At a cross-connection point between the Alarm card and the external equipment, open the circuit under test. Connect a short across the Alarm card sensor input in question. A SENSOR alarm should be reported. If no alarm is reported, the sensor port may be defective.

7. If the Alarm card is determined to be faulty, replace it and return the faulty unit for repair to the location specified by your distributor.



Note: Refer to the Alarm Card Filters table located in the System Configuration and Operation Chapter of the System Reference Manual.

Chapter 11

Voice Cards

E&M Card

11.1 Introduction

This chapter provides switch settings, connector pinouts, configuration, and troubleshooting information for the E&M Voice Cards. These cards are identified as the E&M 2W*8 (810860) and E&M 4W*8ER (811960) and on their faceplate ejectors.

The E&M cards manage the flow of toll-grade voice traffic through the integrated access system. Each card encodes an analog (voice, VF) signal to a digital bitstream at the local integrated access system for transmission over a T1 or E1 network. Each card also decodes the digital signal to analog at the remote system. Both cards support E&M signaling types I, II, IV, and V.

Each card connects to eight CPE voice circuits from a PBX or other user facility. Normal E&M, Transmission-Only, and E&M R2 signaling are supported. The E&M cards also can use the voice compression features of an ADPCM card.

11.2 E&M Card Descriptions

11.2.1 E&M 2W*8 Card Description (810860)

The E&M 2W*8 card has eight voice ports, each with 600-ohm terminating impedance.



Notice!

UL STATEMENT

**OPERATION OF THIS INTERFACE IS LIMITED TO INTRA-BUILDING
CONNECTIONS ONLY**

11.2.1.1 Card Jumper/Switch Settings

The E&M 2W*8 card has four switches (S1 through S4) that you must set before inserting the card into the chassis. These switches establish the type of E&M the card will use on all eight ports. Figure 11-1 shows these switches, Table 11-1 defines their purposes, and Table 11-2 lists the settings for each signaling type.

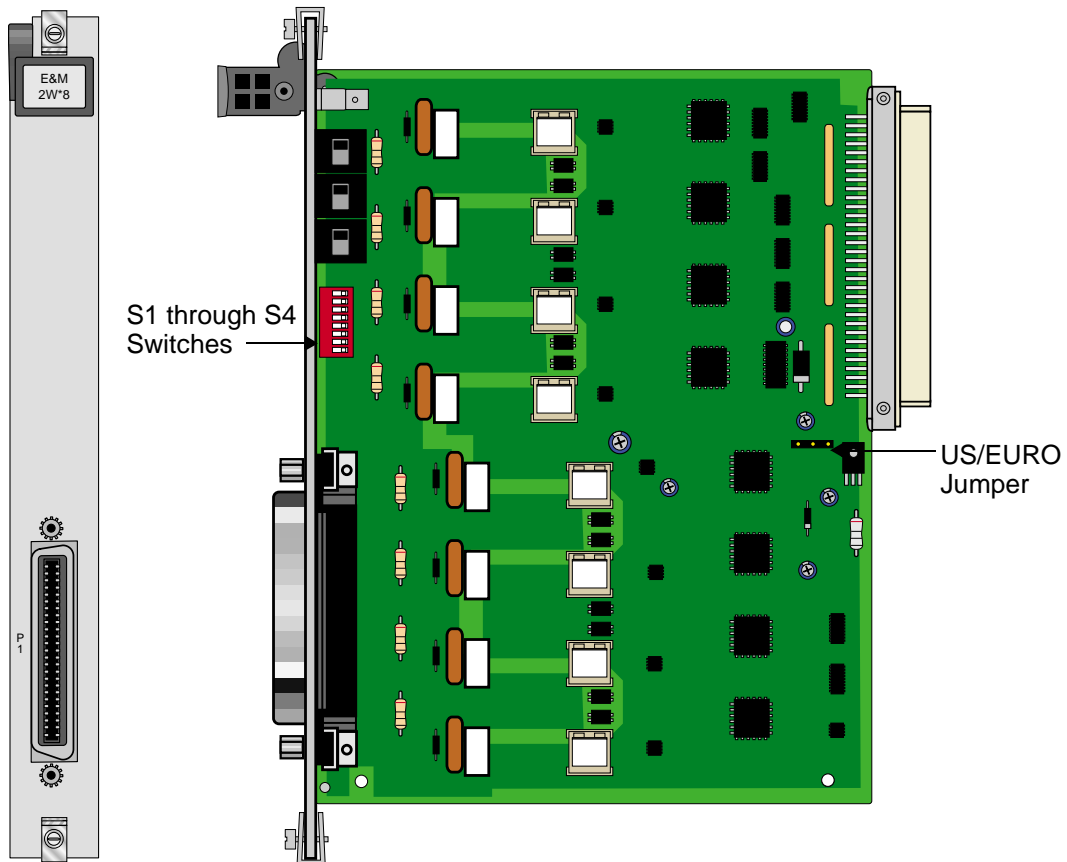

Figure 11-1. Typical E&M Card Switches

Table 11-1. Typical E&M Card Switch Definitions

Switch	Definition
S1	Source of the E (recEive or Earth) lead; can be internal (INT) or external (EXT).
S2	Type of internal source for the E lead; either battery (-48 VDC) or ground (GND).
S3	Type of internal source for the M (transMit or Magnetic) lead; either battery (-48 VDC) or ground (GND).
S4	Normal state of the E lead; either grounded (ON) or open (OFF). Each card port number is designated on the eight-position DIP switch. All eight switches must be set to the same position (all ON or all OFF).

Table 11-2. Typical E&M Card Switch Settings

E&M Type	Direction	S1	S2	S3	S4 (all switches)
I	Normal E&M*	INT	GND	GND	OFF
	Trunk**	INT	BAT	BAT	ON
II	Normal E&M*	EXT	BAT	GND	OFF
	Trunk**	EXT	GND	BAT	OFF
IV	Normal E&M*	EXT	GND	BAT	OFF
	Trunk**	EXT	GND	BAT	OFF
V	Normal E&M*	INT	GND	BAT	OFF
	Trunk**	INT	GND	BAT	OFF
Factory Settings (default)		INT	GND	GND	OFF

*Indicates that the port is attached to a device that generates signaling, such as a PBX.

**Indicates that the port is attached to a device that does not generate signaling, such as a channel bank. In this case, the integrated access system emulates a PBX and generates signaling. This configuration is also known as a Tandem E&M or Pulse Link Repeater (PLR) application.

11.2.1.2 Installing the E&M 2W*8 Card

Insert the E&M 2W*8 card into any user card slot. These slots are U1 to U8 on the two-sided chassis or the front-loading chassis with power supplies on top or P1 to P4 and W1-W4 on the front-loading chassis with power supplies on the side. This card allows you to connect the system to eight 2-wire voice circuits with E&M signaling.

11.2.2 E&M 4W*8 ER Card Description (811960)

The E&M 4W*8 ER card is functionally similar to the E&M 4W*8 card. Unlike that card, though, the ER-type card provides an extended transmit TLP range (-17.5 to +14.5 dB) for dedicated 4-wire modem applications. This range is required for data speeds of 19.2 kbps and higher.



Notice!

UL STATEMENT

**OPERATION OF THIS INTERFACE IS LIMITED TO INTRA-BUILDING
CONNECTIONS ONLY**

11.2.2.1 Card Jumper/Switch Settings

The E&M 4W*8 ER card has four switches (S1 through S4) that you must set before inserting the card into the chassis. These switches establish the type of E&M signaling the card will use on all eight ports. Figure 11-1 shows these switches, Table 11-1 defines their purposes, and Table 11-2 lists the settings for each signaling type.

11.2.2.2 Installing the E&M 4W*8 ER Card

Insert the E&M 4W*8 ER card into any user card slot. These slots are U1 to U8 on the two-sided chassis or the front-loading chassis with power supplies on top or P1 to P4 and W1-W4 on the front-loading chassis with power supplies on the side. This card allows you to connect the system to eight 4-wire voice circuits with E&M signaling.

11.3 E&M Card User Screens and Settings

11.3.1 E&M Card Main Screen

You must configure the E&M card for operation after installing it in the system chassis. This is done from the E&M Main Card Screen, which is shown in Figure 11-2. To go to that screen, highlight the desired card on the System Main Screen, then press <Enter>. The E&M Card Main Screen shows numerous columns of settings, each for one port of the card.

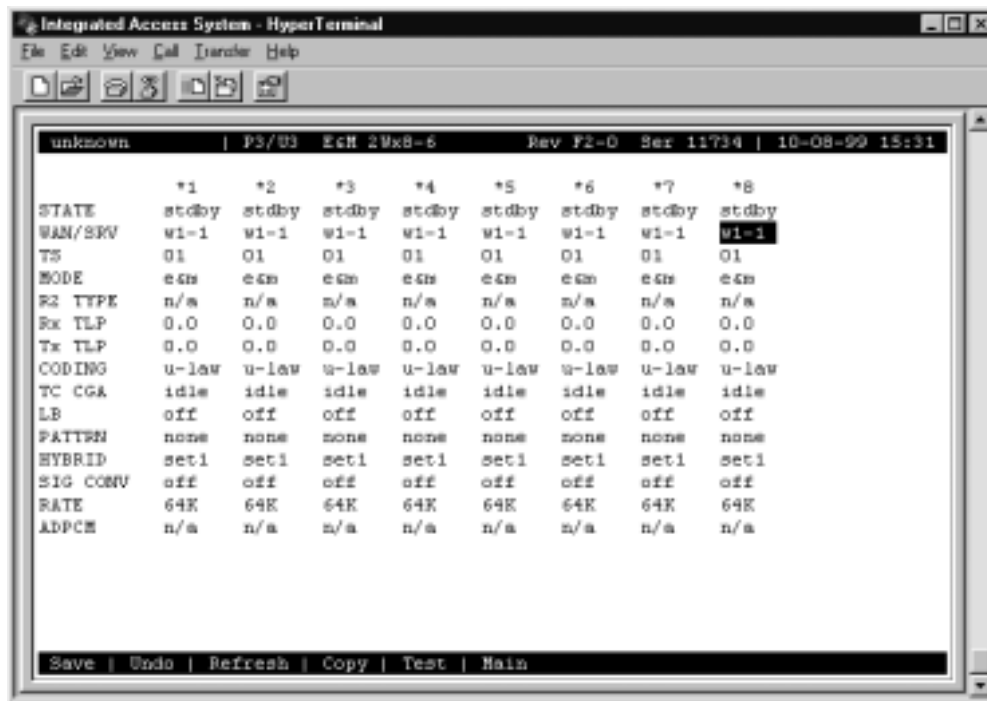

Figure 11-2. Typical E&M Card Main Screen

The bottom highlighted line of this screen shows various actions that you can perform from this screen. You perform the desired action by pressing the associated uppercase letter key. Table 11-3 summarizes these actions. For example, after you configure the E&M card ports, press “s” to save your settings.

Table 11-3. Main Screen Actions

Action	Function
Save	Saves changes to settings.
Undo	Returns all settings to the last saved state.
Refresh	Updates certain time-related information fields that are not automatically updated (i.e., test status).
Copy	Copies the contents of the current column to the next column. Useful if you change a lot of entries in one column and wants to repeat those changes in subsequent columns.
Test	Goes to the Test Screen, from which you can test the E&M card ports. Refer to the Test section of this chapter.
Main	Returns to the System Main Screen. If you make changes to settings and do not save them, you will be prompted to save or lose changes.

Table 11-4 summarizes the configuration settings for the E&M card, along with the available and factory-default option settings. The parameters and settings are also described in the following paragraphs.

Table 11-4. Main Screen Option Settings and Defaults

Parameter	User Options	Notes	Default
STATE	stdby actv		stdby
WAN/SRV	none wan serv user	1	w1-1
TS	01-24 01-31	2	01
MODE	e&m to e&mR2 R2mod		e&m
R2 TYPE	n/a (when MODE is set to e&mR2 or R2mod the default is sl-1)	3	n/a
Rx TLP	-16.3 dB to +7.5 dB		0
Tx TLP	-16.3 dB to +7.5 dB	4	0
CODING	u-law a-law a-inv	5	u-law
TC CGA	idle busy		idle
LB	off dgtl anlg		off
PATTRN	none D-mW quiet		none
HYBRID	n/a set1 to set8 user		n/a
SIG CONV	off on		off
RATE	64K 24K,1 32K,1 40K,1 24K,2 32K,2 40K,2		64K
ADPCM	n/a P1 P2 P3		n/a

Notes:

1. Choosing **wan** allows you to choose a WAN port (w1-1 through w4-2). Choosing **serv** lets you choose an ATM or FRS server card in slot P1, P2, or P3, followed by a logical port on that card. The **user** option is not used. See the WAN/SRV paragraph that follows.
2. Time slot 16 is not available if the port is assigned to an E1 WAN link whose time slot 16 is programmed for **cas** or **ccs**.
3. The default is **sl-1** if the Mode is set to **e&mR2** or **R2mod**.

4. The extended setting range for the 811960 card is from **-16.3** to **+7.5 dB**.
5. The default coding is **a-inv** for E1 and **u-law** for T1.

Choosing a Rate other than **64K** allows you to select an ADPCM slot.

STATE

The State setting determines whether the port is active or inactive. An inactive port does not occupy a time slot on a WAN link. Set this field to **stdby** (standby) for ports that will not be used or that are not yet configured. Or, set it to **actv** (active) for ports that are ready for use.

WAN/SRV

The WAN/SRV setting identifies the WAN link or server card assigned to this port. If you choose **wan**, you also must select the desired port (w1-1 through w4-2) of a WAN card for transmission over a T1 or E1 link. Or, choose **serv** to assign the card port to a server card in the system. This can be an ATM or FRS card, which resides in chassis slot P1, P2, or P3. You must then choose a logical port on that card. The **user** option is not used.

It is not necessary to assign all ports of the same E&M card to the same WAN link or server card, or to contiguous time slots on a WAN link.

TS

The TS setting identifies the time slot on the WAN link to which this port is assigned. This value is from **1** to **24** for T1 links and **1** to **31** for E1 links. However, time slot 16 is not available for E1 links that are programmed for CAS or CCS signaling. For a display of available time slots, refer to the cross-connect map for the WAN link selected.

MODE

The Mode setting specifies whether or not a port uses E&M signaling, or if it operates in the Transmission-Only (TO) mode. Use the **to** mode if you are connecting the port to a four-wire, dedicated-line modem that does not require E&M signaling. The signaling type for all eight ports of an E&M card is defined by setting hardware switches S1 through S4 as described earlier in this chapter. Select **e&m** for standard Type I, II, IV, or V signaling. Select **e&mR2** for symmetrical R2 signaling for calls originating from either the digital or analog side. The **R2mod** setting provides modified R2 signaling for Motorola paging terminal equipment.

R2 TYPE

The R2 Type setting is reserved for future use; its setting is always set to **n/a** and cannot be changed. when the Mode is set to **e&m** or **to**. The signaling type for all eight E&M ports is established by setting hardware switches S1 through S4 as described earlier. If the Mode selected for the port is **e&mR2** or **R2mod**, the R2 Type automatically defaults to **sl-1**.

Rx TLP

The Receive Transmission Level Point (TLP) setting controls the amount of gain or loss added to a signal after it is decoded to analog. To increase the signal level, set the Rx TLP field to a positive number (i.e., the larger the number, the more gain is added). To decrease the signal level, set the Rx TLP field to a negative number (i.e., the more negative the number, the more the signal level is decreased). For example, an incoming signal at -5 dBm can be increased to -2 dBm by setting Rx TLP to **+3 dB**. The Rx TLP range is **-16.3 dB** to **+7.5 dB**.

Tx TLP

The Transmit TLP setting controls the amount of gain or loss added to the voice signal coming in from the local CPE before it is encoded to digital PCM. To increase the incoming signal level, set the Tx TLP field to a negative value (i.e., the more negative the number, the more gain is added). To decrease the signal level, set the Tx TLP setting to a positive number (i.e., the more positive the number, the more the signal level is decreased). For example, an incoming signal at -16 dBm can be increased to 0 dBm by setting Tx TLP to **-16 dB**. For the E&M 4W*8 Card, the Tx TLP range is **-16.5 dB** to **+7.3 dB**. For the E&M 4W*8 ER E&M Card, this range is **-17.5 dB** to **+14.5 dB**.

CODING

The Coding field sets the PCM companding (coding) method used for a port. Generally, the North American T1 environment uses **u-law** (mu-law) coding, and the International E1 environment uses either **a-law** or **a-inv** (inverted A-law) coding. The **a-inv** setting provides a higher ones density on an E1 line than **a-law**. The coding default setting is defined by the type of associated WAN card.

TC CGA

The Trunk Conditioning during Carrier Group Alarm setting defines whether the E&M card port should be placed in the **idle** or **busy** mode upon declaration of a Carrier Group Alarm (CGA) on the WAN link to which the port is assigned. The TC CGA setting has no effect on Transmission-Only circuits, for which the **to** signaling mode is used.

In most cases, you should set this parameter to **busy**. If a call is in progress when the CGA alarm is received, the system holds the call for two seconds, drops it, and then buses out the port to the attached PBX for the duration of the alarm. Once the alarm clears, the system automatically places the port back in the **idle** mode, thereby making it available to the attached PBX.

LB

The LB setting allows you to loop a port back toward the network and far end for testing and troubleshooting. Figure 11-3 shows the available loopbacks. The **dgtl** (digital) loopback sends the incoming digital signal from the network back toward the far end, without decoding it. The **anlg** (analog) loopback sends the decoded analog signal back to the far end. To disable either loopback after testing, set this field to **off**.

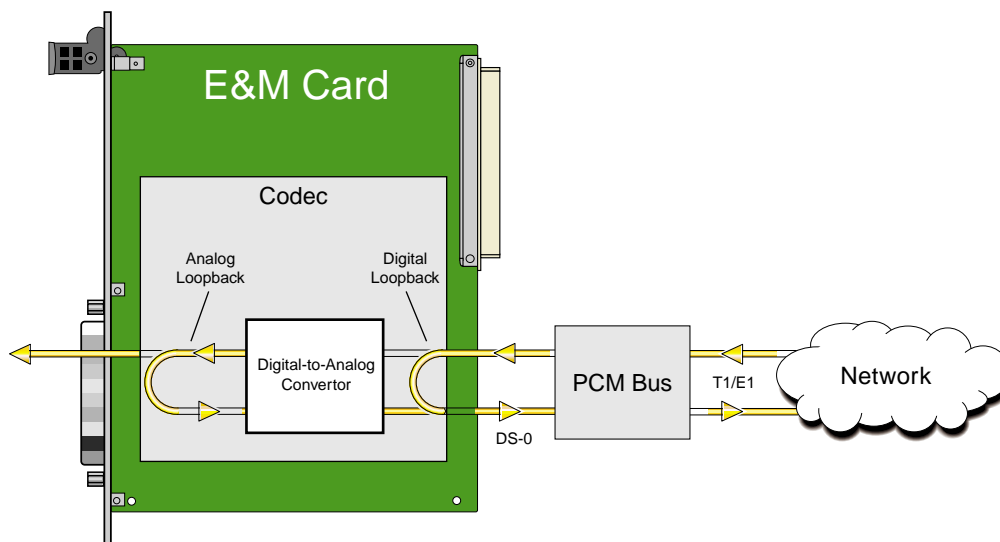

Figure 11-3.E&M Card Loopbacks

PATTRN

The Pattern is the outgoing test pattern to be sent to the selected port by the system. You can send a different pattern to each port. The **none** setting disables the test pattern. The **D-mW** (Digital milliwatt) option sends a 1 kHz tone at 0.0 dBm. The setting of the Rx TLP field adjusts the D-mW signal level before sending the signal to the CPE. The **quiet** option places a 600-ohm termination on the line so that no analog signal is sent (idle mode).

HYBRID

Available for the two-wire 8108 E&M card only, the Hybrid option assigns a three byte pattern to define the adjustment for return loss (similar to Build Out Capacitors). The default, **set1**, balances to the ideal termination of 600Ω @ 2.15mF. The other settings are reserved for future use.

SIG CONV

The Signaling Conversion parameter allows you to change the transmit ABCD signaling bits from ITU (E1) to ANSI (T1) standards. This conversion is completed regardless of the associated type of WAN (CSU/DSX or CEPT).

Select **off** if ANSI signaling is used, or select **on** to convert the transmit signaling from ANSI to ITU according to the Interface Card Conversion Table for E&M signaling. This setting also converts the receive signaling from ITU to ANSI format.

RATE

The Rate parameter allows you to use the voice compression capabilities of an ADPCM card. If that card is not present in the system, the Rate is set to **64k** and cannot be changed. The **64k** setting (default) is the normal encoding/decoding rate for voice circuits.

ADPCM voice channels are assigned in pairs by designating two voice ports (E&M, FXO or FXS) to the same WAN link and time slot, and then selecting rate settings for the pair that add up to 64 kbps. The following pairing combinations are possible:

24K,1+40K,2 (24 kb coding on one side of the time slot and 40 kb coding on the other side of the same time slot)

32K,1+32K,2 (32 kb encoding on each side of a time slot)

40K,1+24K,2 (40 kb coding on one side of the time slot and 24 kb coding on the other side)

Number **1** after the rate setting assigns that portion of the voice port pair to the odd side of the ADPCM pair. Number **2** after the rate setting assigns that portion of the voice port pair to the even side of the ADPCM pair.

For more information about voice port assignments to a time slot and ADPCM card.

ADPCM

The ADPCM parameter lets you assign the current port to an ADPCM card in the system. The default setting is **n/a** and only changes when a Rate smaller than **64k** is selected (see above). You can then select which ADPCM card to use for the port (this assignment is made by chassis slot number). The options are slots **P1**, **P2**, and **P3**.

11.3.2 Test Screen

The Test Screen (Figure 11-4) facilitates testing and maintenance by allowing you to monitor and set the status of the analog signals and/or the A, B, C, and D signaling bits of all E&M circuits on the card. In cross-connect systems, the test option can also send test patterns and tones towards the CPE and network sides of the system.

The Test Screen also shows the signaling type assigned to the card via the switch settings described earlier.

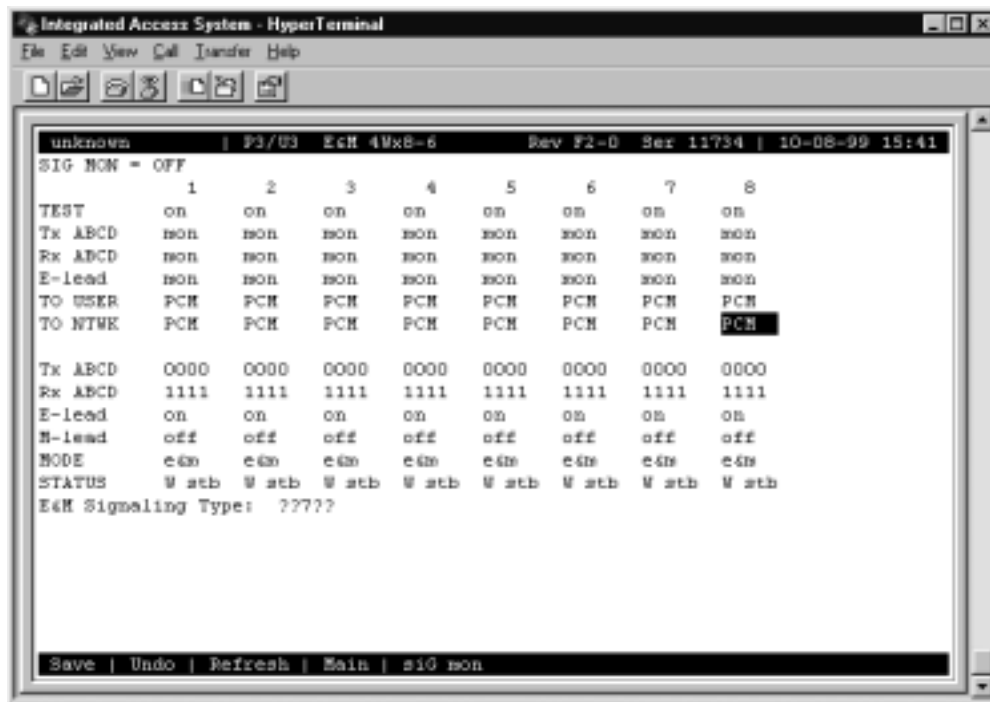

Figure 11-4. Typical E&M Card Test Screen

Table 11-6 lists various operations you can perform from this screen. These appear in the bottom highlighted line of the Test Screen.

Table 11-5. Test Screen Actions

Action	Function
Save	Saves changes to settings.
Undo	Returns all settings to the last saved state.
Refresh	Updates certain time-related information fields that are not automatically updated (i.e., test status).
Copy	Copies the settings of one port to another port that requires the same settings.
Main	Returns to the E&M Card Main Screen. If changes are made to settings and not saved, you will be prompted to save or lose changes.

Table 11-6 summarizes the available test parameters and option settings. The following paragraphs also describe these parameters and settings in detail.

Table 11-6. Test Screen Option Settings and Defaults

Parameter	User Options	Default
TEST	off on	off
Tx ABCD	mon set	mon
Rx ABCD	mon set	mon
E-lead	mon set	mon
TO USER	PCM 300Hz 1kHz 3kHz quiet	PCM
TO NTWK	PCM 300Hz 1kHz 3kHz quiet	PCM
Tx ABCD	Status information only; not user-editable	n/a
Rx ABCD	Status information only; not user-editable	n/a
E-lead	Status information only; not user-editable	n/a
M-lead	Status information only; not user-editable	n/a
MODE	Status information only; not user-editable	n/a
STATUS	Status information only; not user-editable	n/a

SIG MON

The Signaling Monitor feature works with the user card alarm system to detect excessive signaling bit transitions. The system will generate alarms if the number of transitions of any signaling bit in transmit or receive direction for an active port exceeds 255 in any four second interval. The options are **off** and **on**, and they are toggled by pressing “g”.

TEST

The Test parameter shows if the port is in test mode or not. Inactive ports and ports that are assigned to inactive WANs will show a test status of **n/a**. The test status options for active ports are **off** and **on**.

Tx ABCD

The Transmit ABCD setting allows you to either monitor the status of the ABCD signaling bits being transmitted towards the network or set a specific ABCD pattern for testing the transmit side of the circuit. The options for this field are **mon** (monitor) or **set**. Choosing **set** will bring up a four digit field for users to input the ABCD pattern they want to transmit. Any four digit combination of ones and zeros is acceptable for this setting.

Rx ABCD

The Receive ABCD setting allows users either to monitor the status of the ABCD signaling bits being received from the network or to set a specific ABCD pattern for testing the receive side of the circuit.

The options for this field are **mon** (monitor) or **set**. Choosing **set** will bring up a four-digit field for you to specify the ABCD pattern you want to receive. Any four digit combination of ones and zeros is acceptable in this field. The Rx ABCD bits cannot be set in bus-connect systems and the only option is **mon** (monitor).

E LEAD

The E-lead setting allows you to either monitor or set the E-lead state. The options for this field are **mon** (monitor) or **set**. Choosing **set** will bring up the options **off** (which drops the E lead) and **on** (which raises the E lead).

TO USER

In cross-connect systems only, the **To User** parameter allows you to break the circuit and send a 0dB test tone toward the user side of the system. The options for this field are **PCM, 300Hz, 1 kHz, 3 kHz** and **quiet**. Selecting **PCM** causes the PCM signal received from the network to continue to be sent to the user port in the normal manner.

This parameter is not supported in bus-connect systems and will always appear as **n/a**.

TO NTWK

In cross-connect systems only, the **To Network** parameter allows you to break the circuit and send a 0dB test tone toward the network side of the system. The options for this field are **PCM, 300Hz, 1 kHz, 3 kHz** and **quiet**. Selecting **PCM** causes the PCM signal received from the user port to continue to be sent to the network in the normal manner.

This parameter is not supported in bus-connect systems and will always appear as **n/a**.

Tx ABCD

The Transmit ABCD information field shows the current values of the ABCD bits that are being transmitted to the network. If TX ABCD in the top half of the screen is changed via the **set** function mentioned above, and the settings are saved by the **Save** command in the Test Screen, the new bit pattern chosen will be reflected here.

Rx ABCD

The Receive ABCD information field shows the current values of the ABCD signaling bits that are received from the network. If RX ABCD in the top half of the screen is changed via the **set** function mentioned above, and the settings are saved by the **Save** command in the Test Screen, the new bit pattern chosen will be reflected here.

E-Lead

The E-lead information field shows the current status of the E-lead of this port. The settings are either **on** or **off**.

M-Lead

The M-lead information field shows the current status of the M-lead of this port. The settings are either **on** or **off**.

MODE

The Mode informational field shows the current mode of the port that was selected on the main E&M card screen. Valid settings are **e&m**, **to**, **e&mR2**, and **R2mod**.

STATUS

The Status information field shows the current status of the port. Table 11-7 describes the conditions reported by this field.

Table 11-7. Status Information Field Settings

Setting	Meaning
stdby	The E&M port is in standby.
W stb	The WAN card to which the E&M port is assigned is in standby.
W tst	The WAN card to which the E&M port is assigned is under test.
W OOS	The WAN card to which the E&M port is assigned is Out Of Service.
noWAN	No WAN card is configured in the slot to which the E&M port is assigned.
OOS	The E&M card is out of service.
call	Call set-up is in progress.
busy	Call is in progress.
idle	No call is in progress; circuit is available.
TC	The E&M circuit is undergoing Trunk Conditioning because a CGA alarm is in progress on the associated WAN port.
test	The port is under test (i.e., you are actively controlling the circuit by setting values for Tx ABCD, Rx ABCD, or E-lead).
maint	Maint is a status that tells that a specific port is under maintenance.

E&M Signaling Type

This field shows the card's current on-board switch settings, which define the type of E&M signaling used on each port. If necessary, remove the card and reset the switches as previously described until the desired signaling type appears in the screen. The E&M Signaling types are I, II, IV, and V, followed by a "-t" if the card is optioned to provide trunk signaling.

11.3.3 Loopback Screen

The Loopback (Figure 11-5) facilitates loopback detection by allowing the user to enable/disable automatic time out and also get the loopback status of the channel. This feature will provide the digital loopback (both audio and signaling) when activated by a 2713 Hz tone level and duration. When a validated tone is detected the channel disconnects the user and provides loopback of signals received from the network. This loopback is performed at “equal level” without inserting any gain or loss in the path. In addition a “make busy” signal is be applied toward the user. Table 11-8 shows the Loopback screen of actions.

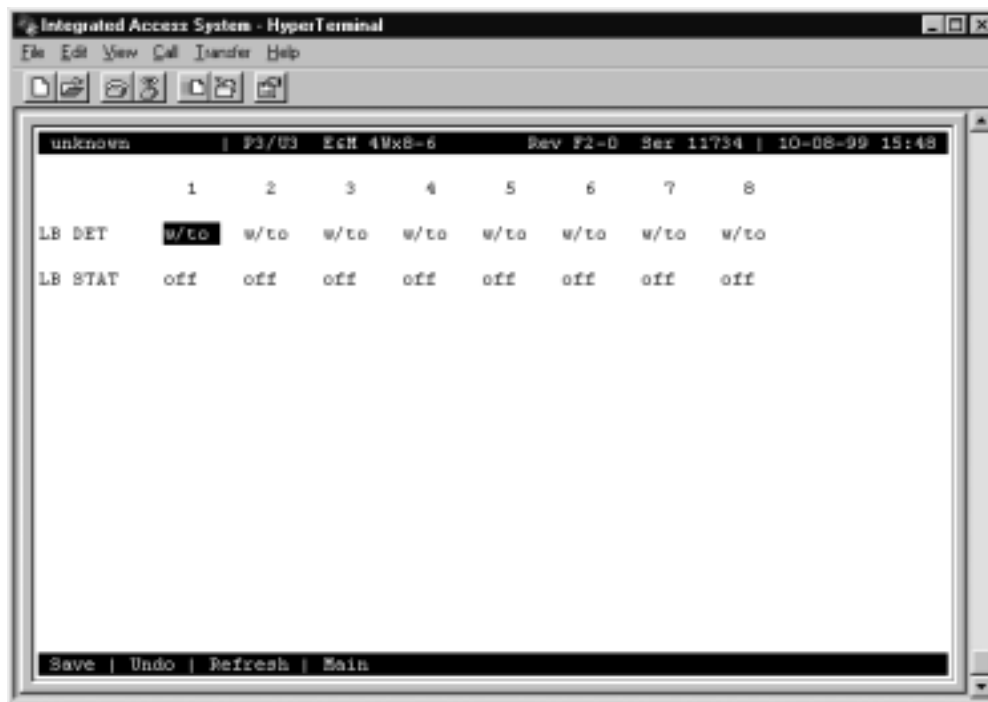

Figure 11-5. Typical E&M Loopback Screen

Table 11-8. Loopback Screen of Actions

Action	Function
Save	Saves changes to settings.
Undo	Returns all settings to the last saved state.
Refresh	Updates certain time-related information fields that are not automatically updated (i.e., loopback status).
Main	Returns to the E&M Card Main Screen. If changes are made to settings and not saved, you will be prompted to save or lose changes.

Table 11-9 summarizes the available loopback parameters and option settings. The following paragraphs also describe these parameters and settings in detail.

Table 11-9. Loopback Screen Option Settings and Defaults

Parameter	User Options	Default
LB DET	w/to on off	w/to
LB STAT	This is information only - no user input is allowed	

LB DET

The user can either enable or disable the loopback detection. The options available are **w/to**, **on** and **off**. The **w/to** option indicates the loopback detection is ON and 20 minute timeout is enabled. The **on** option indicates the loopback detection is ON and timeout is disabled. The **off** option is used for loopback detection is disabled. The default setting is **w/to**.

LB STAT

This is information only - no user input is allowed. This tells the user if a particular port is in loopback state or not.

11.4 E&M Card Error Messages

Refer to Appendix B in the System Reference Guide for further information on Error Messages regarding this card.

11.4.1 E&M Card Troubleshooting

The E&M card may be faulty if a voice signal is not received at one end of a circuit, or if E&M signaling is not detected. The following are possible causes:

- Faulty receiving CPE at the near end (where the problem was first noticed)
- Faulty transmitting CPE at the far (opposite) end
- Faulty cabling between the CPE and E&M card at either end
- Faulty E&M card at either end
- T1 or E1 network failure
- Improper card configuration at either end (e.g., time slot and/or WAN assignments)

First, verify that the T1 or E1 network has not failed. Check for a CGA-Red alarm on the associated WAN port at the end where the incoming VF signal loss is first noticed. The CGA indicates that the incoming network signal was lost (or that the receiving WAN port is out of frame). During the CGA, all voice ports with time slots on that WAN port will also be disabled, and the associated far-end WAN port will be in a CGA-Yellow alarm state. If the network is faulty, you must clear that trouble to restore your circuits.

If the network is okay, verify that the proper WAN ports and time slots are assigned to the associated E&M voice ports at both ends, as previously outlined in this chapter. In a point-to-point network, the near-end and far-end E&M ports should both be assigned the same WAN port and time slot number. Also make sure the other parameters (such as the transmit and receive TLPs) are set properly at both ends.

If the E&M card port parameters are correct at both ends, and if the network is okay, the trouble is isolated to the E&M card or the associated port. Proceed as follows:

1. At the far end, activate an analog loopback on the E&M card port.
2. Send a 0 dBm (digital milliwatt) test signal toward the CPE at that end. That signal will be substituted for the normal signal coming from the far-end CPE; it will be sent back to the CPE at your end via the loopback path.
3. Check your CPE for this signal. If it is present, the far-end CPE or cabling to the far-end E&M card is probably faulty. Disable the loopback and test signal there, and fix the problem. If you still don't receive a signal, go to step 4.

4. At your end, go to the E&M Card's Main Screen and send a digital milliwatt test tone (0 dBm) toward the CPE. If you still don't receive a signal, check the cabling from the E&M card to your CPE, and check the CPE itself. If those items are okay, replace the E&M card at your end.

5. If the E&M card is determined to be faulty, replace it and return the faulty unit for repair to the location specified by your distributor.

11.5 E&M Card Specifications

E&M Cards (810860 and 811960)

Physical Interface (Models 810860 and 811960)

Number of Ports	8
Connectors	1 female 50-pin telco connector

Transmission Performance

Performance	Exceeds requirements of ITU-T G.712 (4-wire) and IT-T G.713 (2-wire)
-------------	--

Signaling

Signaling Types	Switch selectable per card Types I, II, IV and V
Signal Modes	Normal (toward user) and Trunk/Tandem (toward CO) Software selectable per port Transmit Only (to) Standard Type I, II, IV or V E&M (e&m) Symmetrical R2 signaling (e&mr2) Modified R2 (r2mod)

VF Transmission Characteristics

Nominal Transmit TLP	Software selectable Model 8108 -16.5 dB to +7.3 dB in steps of 0.1 dB Model 8115 and 8119 -17.5 dB to +14.5 dB in steps of 0.1 dB
Nominal Receive TLP	Software selectable All Models -16.3 dB to +7.5 dB in steps of 0.1 dB
Termination Impedance	with 2.16 μ f capacitor in series 600 Ohms
PCM Encoding	Software selectable μ -law A-law A-law bit inverted

Attenuation Versus Frequency as per AT&T TR43801 - Relative to 1 kHz with 0 dBm0 input

Frequency	Transmit (A to D)	Receive (D to A)
200 Hz	-0.25 to +3.0 dB	-0.25 to +2.0 dB
300 to 3000 Hz	-0.25 to +0.5 dB	-0.25 to +0.5 dB
3200 Hz	0.25 to +0.75 dB	-0.25 to +0.75 dB
3400 Hz	-0.25 to +1.5 dB	-0.25 to +1.5 dB

Return Loss	Against 600 Ohms, in series with 2.6 μ f with additional 25 Ohms resistor between the channel unit and the return loss measurement set.
Model 810860 2-wire	Echo 28dB min. Singing 20dB min.
Model 811960 4-wire	1kHz 28dB min. 300 to 3000 Hz 23dB min.
4W Return Loss (at 1 kHz)	>20dB Typical > 27dB
2W Return Loss (at 1 kHz)	>15dB Typical > 20dB

Relative Transhybrid Loss Model 810860	Against 600 Ohms, in series with 2.16 μ f termination. Echo 34dB Singing 20dB	
Idle Channel Noise (rcv and xmt)	< -65 dBm0p. Typically < -70 dBm0p or < 20 dBmnc0	
Interchannel Crosstalk	Typical < -75 dBm0 using 7 adjacent channels being distributed with a signal of 0.0 dBm0.	
Total Distortion including Quantization (Signal to Distortion Ratio) Input Frequencies 1004-1020 Hz		
Input Level	Rcv or Xmt	Overall
-30 to 0 dBm0	≥ 35 dB	≥ 33.9 dB
-40 dBm0	≥ 20 dB	≥ 27.6 dB
-45 dBm0	≥ 25 dB	≥ 23 dB
Absolute group delay	< 600 microseconds	
Group Delay Distortion vs. frequency	within boundaries of ITU-T Rec. G.712 Figure 2	
Longitudinal Balance	>46 dB Typical > 50 dB	
Variation of Gain with Input Level	within boundaries of ITU-T Rec. G.713 Figure 7 (2 wire) within boundaries of ITU-T Rec. G.712 Figure 7 (4 wire) Typical gain variation is within ± 0.25 dB from +3 to -50 dBm0	

Diagnostic Capabilities

Diagnostics	Analog loopback Digital loopback "Make Busy" signaling control
-------------	--

Standards Compatibility

Bell System	TR43801
ITU-T	Recommendations G.711, G.712 and G.714
FCC Rules and Regulations	Part 68, and Part 15 - Subpart J

Chapter 12

FXS Card

12.1 Introduction

This chapter provides connector pinout, configuration, and troubleshooting information for the Foreign Exchange - Station (FXS) Voice Cards. These are labeled as the FXS 2W*4-6 and FXS 2W*8-6 cards on their faceplate ejectors.

These cards manage the flow of FXS voice traffic over the network. Each card encodes analog (voice, VF) signals to a digital bitstream at the local system for transmission over a T1 or E1 network. It also decodes the digital signals to analog at the remote system.

Each FXS card has two-wires interfaces that support FXS, Private Line Automatic Ringdown (PLAR), Foreign Exchange Station Defined Network (FXSDN), Dial-Pulse Originating (DPO), and Wink-start operations. The FXS cards also can use the voice-compression features of an ADPCM card.

12.2 FXS Card Description

12.2.1 FXS 2W*8-6 Card Description (812960)

The FXS 2W*8-6 Card has eight ports and provides a 600-ohm terminating impedance on each port. All FXS features are supported by this card.



Notice!

UL STATEMENT

OPERATION OF THIS INTERFACE IS LIMITED TO INTRA-BUILDING CONNECTIONS ONLY

12.2.1.1 Card Jumper/Switch Settings

The FXS 2W*8-6 Card has two sets of jumpers on the motherboard. The jumper JP1 (US/EUR) has two settings. One set is for US domestic applications and the other is for European applications. The default position is U.S.

JP2 (LL/SL) has two settings. One position should be set to SL (Short Loop) for loops not exceeding 700 Ohms, and the other position should be set to LL (Long Loop) for loops comprised between 700 and 1800 Ohms. The default position is LL.



Note: Tip to Ring voltage on short loop option is -33 volts, while the long loop option is -48 volts.

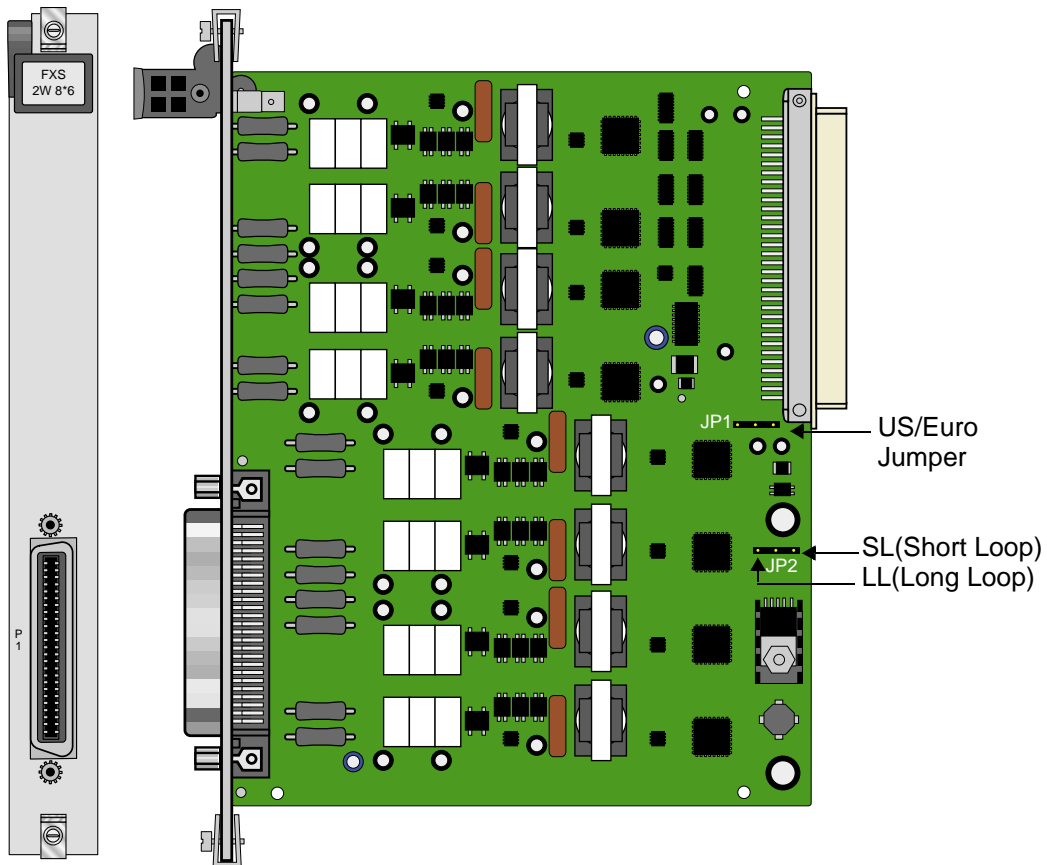

Figure 12-1.FXS 2W*8-6 Card Jumpers Settings

12.2.1.2 Installing the FXS 2W*8-6 Card

Install the FXS 2W*8-6 Card in any user card slot. These slots are U1 to U8 on the two-sided chassis and front-loading chassis with power supplies on top, or P1 to P4 and W1 to W4 on the front-loading chassis with power supplies on the side.

12.3 FXS Card User Screens and Settings

12.3.1 FXS Card Main Screen

You must configure the FXS card for operation after installing it into the system chassis. This is done from the FXS Card Main Screen (see Figure 12-2). To go to that screen, highlight the desired card in the System Main Screen and press <Enter>. This screen shows one configuration column for each port on the card.

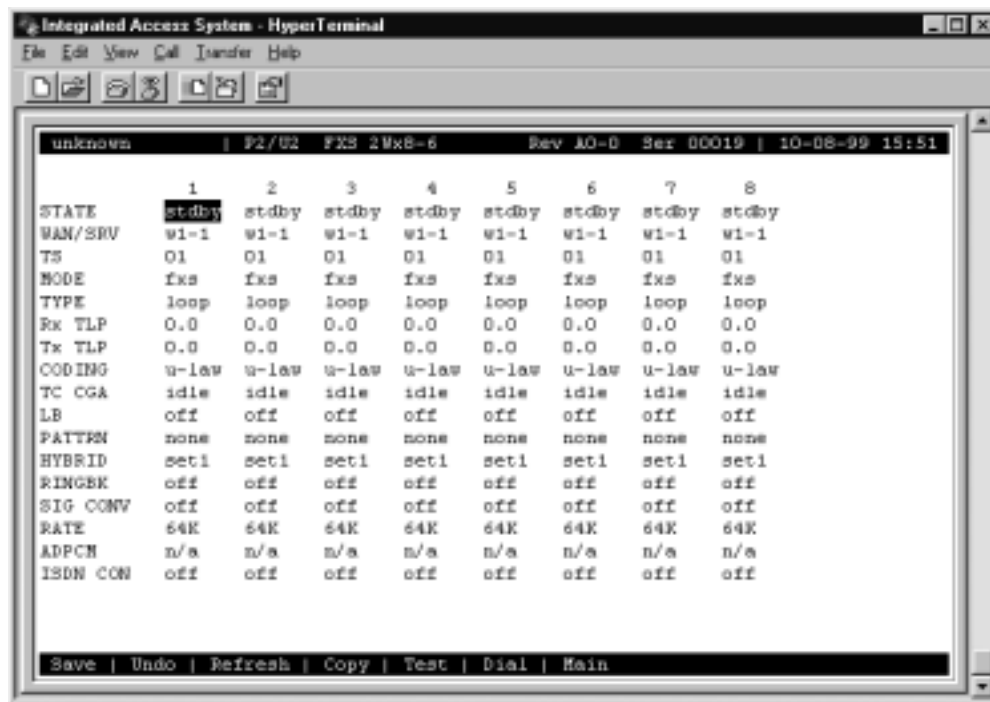

Figure 12-2. Typical FXS Card Main Screen

The bottom highlighted line of this screen shows various actions that you can perform from this screen. You perform the desired action by pressing the associated uppercase letter key. Table 12-1 summarizes these actions. For example, after you configure the FXS card ports, press “s” to save your settings.

Table 12-1. Main Screen Actions

Action	Function
Save	Saves changes to settings.
Undo	Returns all settings to the last saved state.
Refresh	Updates certain time-related information fields that are not automatically updated (i.e., test status).
Copy	Copies the contents of the current column to the next column. Useful if you change a lot of entries in one column and want to repeat those changes in subsequent columns.
Test	Initiates and monitors testing of all FXS card ports. Refer to the Test section of this chapter.
Dial	Primary or Hunt Group telephone number entry menu.
Main	Returns to the System Main Screen. If changes are made to settings and not saved, you will be prompted to either save or lose your changes.

Table 12-2 summarizes the configuration settings for the FXS cards, along with the available and factory-default option settings. The parameters and settings are also described in the following paragraphs.

Table 12-2. Main Screen Option Settings and Defaults

Parameter	User Options	Notes	Default
STATE	stdby actv		stdby
WAN/SRV	none wan serv user	1	w1-1
TS	01-24 01-31	2	01
MODE	fxs fxsdn wink plar dpo slc96		fxs
TYPE	loop lp-fd gs gs-i gs-a 1s-R2 1sR2e R1.5i R1.50 sp	3	loop
Rx TLP	-10.0 dB to +2.0 dB		0.0
Tx TLP	-10.0 dB to +5.0 dB		0.0
CODING	u-law a-law a-inv	4	u-law
TC CGA	idle busy		idle
LB	off dgtl anlg		off
PATTERN	none D-mW quiet		none
HYBRID	set1 to set8 user	5	set1
RINGBK	off on		off
SIG CONV	off on		off
RATE	64K 24K,1 32K,1 40K,1 24K,2 32K,2 40K,2	6	64K
ADPCM	n/a P1 P2 P3		n/a
ISDN CON	off on		off

Notes:

19. Choosing **wan** allows you to choose a WAN port (w1-1 through w4-2). Choosing **serv** lets you choose an ATM or FRS server card in slot P1, P2, or P3, followed by a logical port on that card. *If your system has the FRS card installed and you want to use voice compression you need to install the Low Bit Rate Voice (LBRV) card. However, if your*

system has the ATM card installed you can proceed directly with voice compression (there is no need for the LBRV Card to be installed.) The **user** option is not used. See the WAN/SRV paragraph that follows.

20. Time slot 16 is not available if the port is assigned to an E1 WAN link whose time slot 16 is programmed for CAS or CCS.
21. These options are only valid if the Mode is set to **fxs**. If the Mode is **fxsdn**, the Type options are the same as above with the addition of **fgd**, **boa**, and **lp-sr**. If the Mode is **plar**, the Type options are **d3** or **d4**. If the Mode is **dpo**, the Type setting will automatically default to **dpo**. If the Mode is **wink**, the Type options are **loop**, **lp-fd**, **gs**, **gs-i**, and **gs-a**.
22. The default is **a-inv** for E1 and **m-law** for T1. These values will change depending upon the WAN link selected.
23. The default (**set1**) is the only active option. It balances to the ideal termination of 600 ohms + 2.15 uF. The other settings are reserved for future use.
24. Choosing a Rate other than 64K allows you to select an ADPCM.

STATE

The State setting determines whether the port is active or inactive. An inactive port does not occupy a time slot on a WAN link. Set the State setting to **stdby** (standby) for ports that are not to be used or that have not yet been configured. Set it to **actv** (active) for ports that are ready for use.

WAN/SRV

The WAN/SRV setting identifies the WAN link or server card assigned to this port. If you choose **wan**, you also must select the desired port (w1-1 through w4-2) of a WAN card for transmission over a T1 or E1 link. Or, choose **serv** to assign the card port to a server card in the system. This is an ATM or FRS card, which resides in chassis slot P1, P2, or P3. You must then choose a logical port on that card. The **user** option is not used.

It is not necessary to assign all ports of the same FXS card to the same WAN link or server card, or to contiguous time slots on a WAN link.

TS

The TS setting identifies the time slot on the WAN link to which this port is assigned. Values range from **1** to **24** for T1 links and **1** to **31** for E1 links. Time slot 16 is not available on E1 links that are programmed for **cas** or **ccs** signaling. For a display of the available time slots, refer to the cross-connect map for the WAN link; see Chapter 4, *System Configuration and Operation* in the System Reference Guide for information about viewing cross-connect maps.

MODE

The Mode setting should be determined by the type of equipment to which the user is connecting the port. All options use two-wire balanced connections. The **fxs** (Foreign Exchange Station) option allows users to connect the system to a two-way (both inbound and outbound calls) PBX trunk or a key system trunk. The system requires a ringing generator for this option. The **fxsdn** (Foreign Exchange Station-Defined Network) option provides access to new services offered by advanced networks from many major carriers. The system requires a ringing generator for this option. The **wink** option uses the same type of signaling as **fxsdn** and provides a 150-millisecond delay, then a 200-millisecond "wink" back to the central office when the FXS card sees an off-hook condition from the central office. The system requires a ringing generator for this option.

The **plar** (private line automatic ringdown) option provides point-to-point unswitched connections between two telephone sets. This configuration is usually not attached to an exchange or switch; rather it provides a "hot line" between two locations. The unit requires a ringing generator for this option.

The **dpo** (Dial Pulse Originating) option allows the unit to attach to out-going one-way trunks from a PBX, key system, or a telephone set. This option is very similar to the **fxs** option; however, the system does not require a ringing generator.

The **slc96** (Subscriber Loop Carrier 96) option connects the card to one-way outgoing trunks from a PBX, CENTREX, key system, or telephone set to an SLC[®]-96 channel. The **slc96** mode also must be active on the associated WAN card.

TYPE

The Type setting matches the signaling behavior of the FXS equipment to the remote switch. Use the **loop** (loop-start) option with POTS stations and simple PBX trunks. Use the **lp-fd** (loop-start with Forward Disconnect) option when connecting to automated answering equipment. Use the **gs** (ground-start) option with two-way PBX trunks. This setting helps prevent glaring and call collisions. Use **gs-i** (ground-start immediate) for equipment requiring a fast response time to the station or PBX. Use **gs-a** (ground-start automatic) for equipment requiring fast-response time to the central office. Use **ls-R2** for CCITT signaling used internationally (immediate R2) which provides immediate seizure acknowledgment to the network. Your selection must match the behavior of both the station equipment and remote central office or PBX.

The **lsR2e** R2 Signaling for Ericsson switch for incoming and outgoing call modes. The tables below represent FXS **ls-R23** signaling modes.

FXS-LS-R2E Office Originate - Incoming Calls (ls-R2e)

In this case, RxAB is Forward signaling. TxAB is Backward signaling. See Table 12-3.

Table 12-3. Incoming Calls (ls-R2e)

State	T/R Stat	T/R Cntl	TxAB	RxAB	Note
Idle/Released	Open	TgRb	10	10	
Seized	Open	Ringer	10	00*	Ringer 2s on, 4s off
Seizure Ack	Open or Loop		10	00	N/A
Answered	Loop*	TbRb	00	00	
Clear Forward	Loop	TgRb	00	10*	No action
Idle/Released	Open*	TgRb	10	10	
Clear Back	Open*	TgRb	10	00	
Idle/Released	Open	TgRb	10	10*	
Blocked	Open or Loop		11	10	N/A

FXS-LS-R2E Station Originate - Outgoing Calls (ls-R2e)

In this case, RxAB is forward signaling, RxAB is Backward signaling. See Table 12-4.

Table 12-4. Outgoing Calls (ls-R2e)

State	T/R Stat	T/R Cntl	TxAB	RxAB	Note
Idle/Released	Open	TgRb	10	10	
Seized	Loop*	TgRb	00	10	
Seizure Ack.	Loop	TgRb	00	10	N/A
Answered	Loop	TbRg	00	00*	Battery Reversal
Clear Forward	Open*	TbRg	10	00	
Idle/Released	Open	TgRb	10	10*	
Clear Bcak	Loop	TgRb	00	10*	Battery Normal
Idle/Released	Open*	TgRb	10	10	
Blocked			10	11	N/A

The **R1.5 Signaling** is a special state machine for Russia to support **R1.5** signaling. The IDLE signaling is asymmetrical which means that the state machines have to distinguish the direction of a call. Therefore there are different modes for incoming and outgoing calls that can be used for a call in one direction. The two new types are supported in FXS Mode only

and the types are **R1.5i** and **R1.5o**. **R1.5i** is for incoming calls (Office Originate) and **R1.5o** is for outgoing calls (Station Originate). The following tables below represent the FXS R1.5i and R1.5o signaling.

FXS-LS-R1.5 Office Originate - Incoming Calls (R1.5i)

In this case calls can only be originated from the network (incoming calls) RxAB is Forward signaling. TxAB is Backward signaling. See Table 12-5.

Table 12-5. Incoming Calls (R1.5i)

State	T/R Stat	T/R Cntl	TxAB	RxAB	Note
Idle/Released	Open	TgRb	01	11	
Seized	Open	Ringer	01	10*	Ringer 2s on, 4s off
SeizureAck	Open or Loop		11*	10	Automatic Ack. (200ms min)
Answered	Loop*	TgRb	10	10	
Clear Forward	Loop	TgRb	10	11 or 00*	
Released	Open*	TgRb	00	11	For 200 ms
Idle	Open	TgRb	01	11	Automatic in 200 ms
Clear Back	Open*		00	10	
Idle/Release	Open	TgRb	01	11*	
Blocked	Open or Loop		11*	11	Test mode

FXS-LS-R1.5 Station Originate - Outgoing Calls (R1.5o)

In this case calls can only be originated from the station or PBX ports (outgoing calls), TxAB is Forward signaling, RxAB is Backward Signaling. See Table 12-6.

Table 12-6. Outgoing Calls (R1.5o)

State	T/R Stat	T/R Cntl	TxAB	RxAB	Note
Idle/Released	Open	TgRb	11	01	
Seized	Loop*	TgRb	10	01	
Seizure Ack.	Loop	TgRb	10	11*	CO Ack.
Pulse Dial Break	Break*	TgRb	00	11	
Answered	Loop	TgRb	10	10*	
Busy	Loop	TgRb	10	00*	
Clear Forward	Open*	TgRb	11	10 or 00	
Clear Back	Open	TgRb	11	00*	Optional
Idle/Released	Open	TgRb	11	01 or 10 or 11*	
Clear Back	Loop	TgRb	10	00*	
Clear Forward	Open*	TgRb	11	00	Optional
Idle/Released	Open*	TgRb	11	01*	
Blocked		TgRb	11	11*	Blocked at CO

Use **sp** for Single Party signaling in an ESF (Extended SuperFrame) mode along with Feature Group "D" high-speed modem services that require special software. The choice of **boa** (bill on answer) sends a signal back to the office when the customer answers the phone, to start billing for the call. An additional choice of **lp-sr** (loop-start short ring). Same as loop option except the ringing time is 1 second ON and 2 second OFF instead of 2 second ON and 4 second OFF (using existing option **loop/lp-fd**).

Selecting the **plar** option for the Mode of this port causes the system to offer **d3** and **d4**, which are the two common PLAR types. Both of these meet the pre-1988 and post-1988 specifications for PLAR circuits. If you select **dpo** as the Mode, the Type automatically defaults to **dpo**.

If **slc96** is selected for Mode, the two options supported are **sp** (single-party POTS) and **uvg** (universal voice-grade).



CAUTION!

Before activating this port, verify the behavior expected by both the station equipment and remote central office equipment, and be sure the systems are properly configured.

Rx TLP

The Receive Transmission Level Point (TLP) setting controls the amount of gain or loss added to the incoming signal after it is decoded to analog. To increase the signal level, set the Rx TLP setting to a positive value (i.e., the larger the number, the more gain is added). To decrease the signal level, set the Rx TLP setting to a negative value (i.e., the more negative the number, the more the signal level is decreased). For example, an incoming signal at -5 dBm can be increased to -3 dBm by setting Rx TLP to **+2 dB**. The Rx TLP range is **-10.0 dB** to **+2.0 dB**.

Tx TLP

The Transmit TLP setting controls the amount of gain or loss added to a voice signal from the CPE before it is encoded to digital PCM. To increase the signal level, set the Tx TLP setting to a negative value (i.e., the more negative the number, the more gain is added). To decrease the signal level, set the Tx TLP setting to a positive value (i.e., the more positive the number, the more the signal level is decreased). For example, an incoming signal at -5 dBm can be increased to -2 dBm by setting the Tx TLP to **-3 dB**. The Tx TLP range is **-10.0 dB** to **+5.0 dB**.

CODING

The Coding setting sets the PCM companding method used for a port. Generally, the North American T1 environment uses **m-law** coding, and the International E1 environment uses **a-law** or **a-inv** (inverted A-law) coding. The **a-inv** setting provides a higher ones density than **a-law**. The default coding setting is determined by the type of associated WAN card.

TC CGA

The Trunk Conditioning during Carrier Group Alarm setting defines whether the FXS port should be forced **idle** or **busy** upon declaration of a Carrier Group Alarm (CGA) on the WAN link to which the port is assigned. In most cases, you should set this parameter to **busy**. If a call is in progress when the CGA alarm is received, the system will hold the call for two seconds, drop it, and then busy out the port to the attached PBX for the duration of the alarm. Once the alarm clears, the system will automatically place the port back in the **idle** mode, making it available to the PBX.

LB

The Loopback field lets you loop the port back toward the network and far end. The **dgtl** (digital) loopback sends the incoming digital DS0 signal back to the far end without decoding it. The **anlg** (analog) loopback sends the decoded analog signal back to the far end after decoding and then re-encoding it. Figure 12-3 shows the loopback options, which allow you to test and troubleshoot the FXS card. To disable a loopback, set this field to **off**.

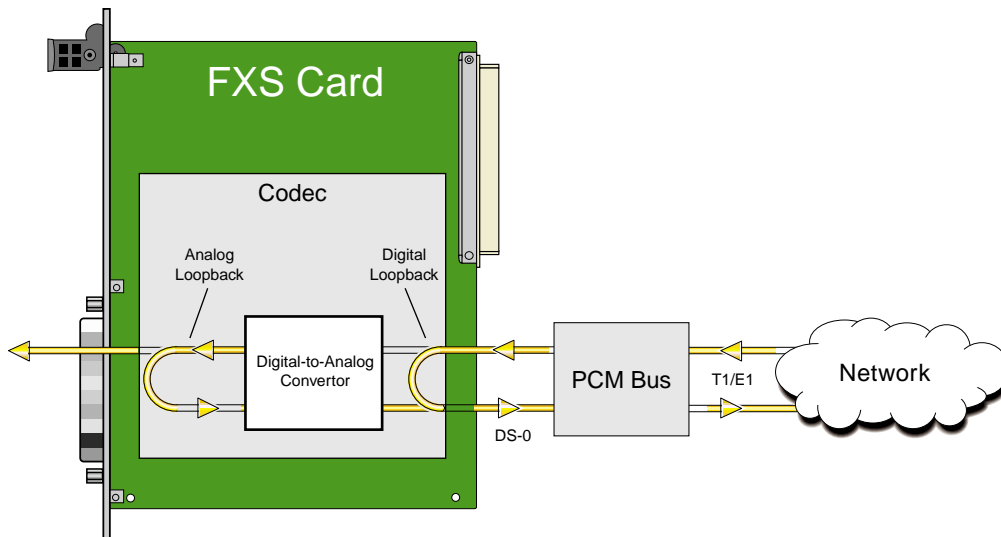

Figure 12-3.FXS Card Loopbacks

PATTRN

The Pattern field selects an outgoing test pattern for the current card port. The test pattern is generated by the system and sent to the selected port. You can select a different pattern for each port. The **none** option disables the test pattern. The **D-mW** (Digital milliwatt) option sends a 1 kHz tone at 0.0 dBm. The setting of the Rx TLP setting affects the D-mW signal level. The **quiet** option places a 600-ohm termination on the line so that no analog signal is sent (idle mode).

HYBRID

The Hybrid option assigns a three byte pattern to define the adjustment for return loss (similar to Build Out Capacitors). The default, **set1**, balances to the ideal termination of 600 ohms + 2.15 uF. The other settings are reserved for future use.

RINGBK

The ringback setting specifies whether a ringback tone is generated by the system and sent towards the network. Turn this option **off** when the network service does not provide an audible ringing tone to the calling party.

SIG CONV

The Signaling Conversion parameter allows you to change the transmit ABCD signaling bits from CCITT (E1) to ANSI (T1) standards. This conversion is completed regardless of the type of WAN card (CSU/DSX *or* CEPT) to which the FXS card is attached.

The options are **off** if ANSI signaling is used and **on** to convert transmit signaling from ANSI to CCITT format according to the Interface Card Conversion Table for FXS signaling. This setting also converts receive signaling from CCITT to ANSI.

RATE

The Rate parameter allows you to use the voice compression capabilities of an ADPCM card. If that card is not present in the system, the Rate stays at **64k** and cannot be changed. The **64k** option is the normal encoding/decoding rate for voice circuits.

ADPCM voice channels are assigned in pairs by designating two voice ports (E&M, FXO, or FXS) to the same WAN link and time slot, and selecting rate settings for the pair that add up to 64 kbps. The following combinations are possible:

- **24K,1+40K,2** (24 kb coding on one side of the time slot and 40 kb coding on the other side of the same time slot)
- **32K,1+32K,2** (32 kb encoding on each side of a time slot)
- **40K,1+24K,2** (40 kb coding on one side of the time slot and 24 kb coding on the other side)

Number **1** after the rate setting assigns that portion of the voice port pair to the odd side of the ADPCM pair. Number **2** after the rate setting assigns that portion of the voice port pair to the even side of the ADPCM pair.

The number **1** after the rate setting assigns that portion of the voice port pair to the odd side of the ADPCM pair. The number **2** after the rate setting assigns that portion of the voice port pair to the even side of the ADPCM pair.

For more information about voice port assignments to the ADPCM card, please consult the ADPCM section of the *Server Card Reference Guide*.

ADPCM

The ADPCM parameter lets the user choose which ADPCM card to place this E&M port. The default setting is **n/a** and only changes when a Rate smaller than **64k** is selected (see above). The user is then allowed to select which ADPCM card to use for the port (this assignment is made by chassis slot number). The options are slots **P1**, **P2**, and **P3**.

ISDN CON

The ISDN Connect parameter displays whether the ISDN connection is on or off. The default setting is always off.

12.3.2 Test Screen

The Test option facilitates testing and maintenance by allowing you to monitor and set the status of the analog interface leads, and to monitor or set the value of the A, B, C, and D signaling bits of all FXS circuits on that card. In cross-connect systems, the test option also allows you to apply test patterns and tones towards the user and network sides of the system.

Figure 12-4 shows the FXS Card Test Screen parameters, Table 12-7 lists some actions you can perform from this screen, and Table 12-8 shows the settings for each parameter.

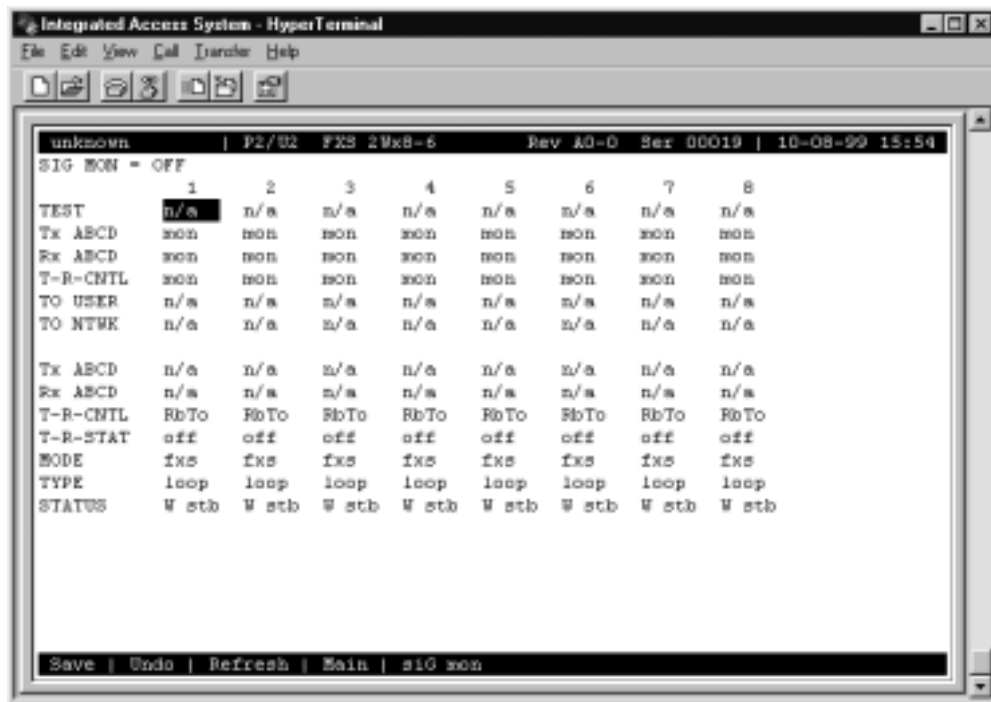

Figure 12-4. Typical FXS Card Test Screen

Table 12-7. Test Screen Actions

Action	Function
Save	Saves changes to settings.
Undo	Returns all settings to the last saved state.
Refresh	Updates certain time-related information fields that are not automatically updated (i.e. performance and test data).
Main	Returns to the FXS Card Main Screen. If changes are made to settings and not saved, you will be prompted to save or lose changes.
siGmon	Used with the user card alarm system to notify you of excessive signaling bit transitions.

Table 12-8. Test Screen Option Settings and Defaults

Parameter	User Options	Default
SIG MON	off on	off
TEST	off on	off
Tx ABCD	mon set	mon
Rx ABCD	mon set	mon
T-R-CNTL	mon set	mon
TO USER	PCM 300Hz 1kHz 3kHz quiet	PCM
TO NTWK	PCM 300Hz 1kHz 3kHz quiet	PCM
Tx ABCD	Status information only; not editable	n/a
Rx ABCD	Status information only; not editable	n/a
T-R-CNTL	Status information only; not editable	n/a
T-R-STAT	Status information only; not editable	n/a
MODE	Status information only; not editable	n/a
TYPE	Status information only; not editable	n/a
STATUS	Status information only; not editable	n/a

SIG MON

The Signaling Monitor feature works with the user card alarm system to detect excessive signaling bit transitions. The system will generate alarms if the number of transitions of any signaling bit in transmit or receive direction for an active port exceeds 255 in any four second interval. The options are **off** and **on**, and they are toggled by pressing “**g**” (**siGmon** command) in the Test Screen.

TEST

The Test parameter shows if the port is in test mode or not. Inactive ports and ports that are assigned to inactive WANs will show a test status of **n/a**. The test status options for active ports are **off** and **on**.

Tx ABCD

The Transmit ABCD setting allows the user to either monitor the status of the ABCD signaling bits being transmitted towards the network or set a specific ABCD pattern for testing the transmit side of the circuit. The options for this field are **mon** (monitor) or **set**. Choosing **set** will bring up a four digit field for users to input the ABCD pattern they want to transmit. Any four-digit combination of ones and zeros is acceptable for this setting.

Rx ABCD

The Receive ABCD setting allows the user to either monitor the status of the ABCD signaling bits being received from the network or set a specific ABCD pattern for testing the receive side of the circuit. The options for this field are **mon** (monitor) or **set**. Choosing **set** will bring up a four digit field for users to input the ABCD pattern they want to receive. Any four digit combination of ones and zeros is acceptable.

T-R-CNTL

The Tip and Ring Control setting allows you to either **mon** (monitor) or **set** (set) the state of the Tip and Ring leads of an FXS port. Choosing **set** will display the following options (**b** = battery, **o** = open, **g** = ground):

- **RbTo** (-48V is applied to the Ring lead and the Tip lead is open)
- **TbRo** (-48V is applied to the Tip lead and the Ring lead is open)
- **RbTg** (-48V is applied to the Ring lead and the Tip lead is grounded)
- **TbRg** (-48V is applied to the Tip lead and the Ring lead is grounded)

TO USER

In cross-connect systems only, the To User parameter allows you to break the circuit and send a 0 dB test tone on the user side of the system. The options for this field are **PCM**, **300Hz**, **1kHz**, **3kHz**, and **quiet**. Choose **PCM** if you do not want to inject a tone toward the CPE. In this case, the PCM signal received from the network is still sent to the CPE in the normal manner.

TO NTWK

In cross-connect systems only, the To Network parameter allows you to break the circuit and send a 0dB test tone on the network side of the system. The options for this field are **PCM**, **300Hz**, **1kHz**, **3kHz**, and **quiet**. Choose **PCM** if you do not want to inject a tone toward the network. In this case, the PCM signal received from the CPE is still sent to the network in the normal manner.

Tx ABCD

The Transmit ABCD informational field shows the current values of the ABCD bits that are being transmitted to the network. If TX ABCD in the top half of the screen is changed via the **set** function mentioned above, and the settings are saved by the Save command in the Menu of Actions, the new bit pattern chosen will be reflected here.

Rx ABCD

The Receive ABCD informational field shows the current values of the ABCD signaling bits that are received from the network. If RX ABCD in the top half of the screen is changed via the **set** function mentioned above, and the settings are saved by the Save command in the Menu of Actions, the new bit pattern chosen will be reflected here.

T-R-CNTL

The Tip and Ring Control informational field shows the current status of the Tip and Ring leads of the FXS port from the perspective of the system. The possible values are as follows (**b** = battery, **o** = open, **g** = ground):

- **RbTo** (-48V is applied to the Ring lead and the Tip lead is open)
- **TbRo** (-48V is applied to the Tip lead and the Ring lead is open)
- **RbTg** (-48V is applied to the Ring lead and the Tip lead is grounded)
- **TbRg** (-48V is applied to the Tip lead and the Ring lead is grounded)
- **ring** (the ringing voltage is applied between Tip and Ring)

T-R-STAT

The Tip and Ring Status informational field describes what the attached device is doing with the Tip and Ring leads of the FXS port. The possible values are:

- **loop** (attached device is connecting Tip and Ring together)
- **rgnd** (the Ring lead is grounded by the attached device)
- **open** (Ring lead is not connected to either the Tip lead or to ground)

MODE

The Mode informational field shows the current mode of the port that was selected on the main FXS card Screen. Valid settings are **fxs**, **fxsdn**, **wink**, **plar**, **dpo**, or **slc96**.

TYPE

The Type informational field shows the current status of the signal field selected on the main FXS card screen for this port. Valid settings for **fxs** and **wink** modes are **loop** (loop start), **lp-fd** (loop start–forward disconnect), **gs** (ground start), **gs-i** (ground start immediate) and **gs-a** (ground start automatic). Valid settings for **fxsdn** modes are **loop** (loop start), **lp-fd** (loop start–forward disconnect), **gs** (ground start), **gs-i** (ground start immediate), **gs-a** (ground start automatic) and **fgd** (Feature Group "D"). Valid settings for the **plar** mode are **d3** and **d4**. The only valid setting for the **dpo** mode is **dpo** (dial pulse originating).

STATUS

The Status field shows the current status of the port. Table 12-9 lists and describes all of the possible conditions reported by this field.

Table 12-9. Status Information Field Settings

Setting	Meaning
stdby	The FXS port is in standby.
W stb	WAN card to which the FXS port is assigned is in standby.
W tst	WAN card to which the FXS port is assigned is under test.
W OOS	WAN card to which the FXS port is assigned is out of service.
noWAN	There is no WAN card configured in the slot to which the FXS port is assigned.
call	Call set-up is in progress.
busy	Call is in progress.
idle	No call is in progress (port is available for a call).
TC	The port is in Trunk Conditioning because a CGA alarm occurred on the associated WAN port.
test	A test is in progress on the port (i.e., you are actively controlling the circuit by setting values for Tx ABCD or Rx ABCD).
maint	The port is in a maintenance condition.

12.4 FXS Error Messages

Refer to Appendix B in the System Reference Guide for further information on Error Messages regarding this card.

12.5 FXS Card Troubleshooting

The FXS card may be faulty if a voice signal is not received at one end of a circuit, or if signaling is not detected. The following are possible causes:

- Faulty receiving CPE at the near end (where the problem was first noticed)
- Faulty transmitting CPE at the far (opposite) end
- Faulty cabling between the CPE and FXS card at the near end
- Faulty cabling between the CPE and FXS or FXO card at the far end
- T1 or E1 network failure
- Improper card configuration at either end (e.g., time slot and/or WAN port assignments)

First, verify that the T1 or E1 network has not failed. Check for a CGA-Red alarm on the associated WAN port at the end where the incoming VF signal loss is first noticed. The CGA indicates that the incoming network signal was lost (or that the receiving WAN port is out of frame). During the CGA, all voice ports with time slots on that WAN port will also be disabled, and the associated far-end WAN port will be in a CGA-Yellow alarm state. If the network is faulty, you must clear that trouble to restore your circuits.

If the network is okay, verify that the proper WAN ports and time slots are assigned to the associated FXS and FXO voice ports at both ends, as previously outlined in this chapter. In a point-to-point network, the near-end and far-end FX card ports should both be assigned the same WAN port and time slot number. Also make sure the other parameters (such as the transmit and receive TLPs) are set properly at both ends.

If the FX card port parameters are correct at both ends, and if the network is okay, the trouble is isolated to the FXS card or the associated port. Proceed as follows:

1. At the far end, activate an analog loopback on the FX card port.
2. Send a 0 dBm (digital milliwatt) test signal toward the CPE at that end. That signal will be substituted for the normal signal coming from the far-end CPE; it will be sent back to the CPE at your end via the loopback path.
3. Check your CPE for this signal. If it is present, the far-end CPE or cabling to the far-end FX card is probably faulty. Disable the loopback and test signal there, and fix the problem. If you still don't receive a signal, go to step 4.

4. At your end, go to the FXS Card Main Screen and send a digital milliwatt test tone (0 dBm) toward the CPE. If you still don't receive a signal, check the cabling from the FXS card to your CPE, and check the CPE itself. If those items are okay, replace the FXS card at your end.

5. If the FXS card is determined to be faulty, replace it and return the faulty unit for repair to the location specified by your distributor.

12.6 FXS Card Specifications

FXS Cards (812960 2-wire)		
Number of Ports		
Models 812960	8 ports	
Physical Interface		
Connector	1 female 50-pin telco connector	
Transmission Performance		
Performance	Exceeds requirements of ITU-T Rec. G.713	
Signaling Modes		
Model 812X Signaling Modes	Software selectable on a per port basis Foreign Exchange Station (FXS) Loop Start and Ground Start Foreign Exchange Station - Defined Network (FXSDN) Private Line Automatic Ringdown (PLAR) Dial Pulse Originating (DPO)	
Termination Impedance		
Model 812960	600 Ohms with 2.16 μ F	
VF Transmission Characteristics		
Nominal Transmit TLP	-10.0 dB to +5.0 dB in steps of 0.1 dB	
Nominal Receive TLP	-10.0 dB to +2.0 dB in steps of 0.1 dB	
PCM Encoding	Software selectable on a per port basis	
Attenuation Versus Frequency Relative to 1 kHz with 0 dBm0 input		
Frequency	Transmit (A to D)	Receive (D to A)
200 Hz	-0.25 to +3.0 dB	-0.25 to +2.0 dB
300 to 3000 Hz	-0.25 to +0.5 dB	-0.25 to +0.5 dB
3200 Hz	0.25 to +0.75 dB	-0.25 to +0.75 dB
3400 Hz	-0.25 to +1.5 dB	-0.25 to +1.5 dB
Return Loss (at 1 kHz)	\geq 28 dB	
Transhybrid Loss	34dB	
Idle Channel Noise (rcv and xmt)	< -65 dBm0p Typical < -70 dBm0p or < 20 dBrcn0	
Interchannel Crosstalk	Typical < -75 dBm0 using 7 adjacent channels being disturbed with a signal of 0.0 dBm0	
Total Distortion including Quantization (Signal to Distortion Ratio) Input Frequencies 1004-1020 Hz		
Input Level	Rcv or Xmt	Overall
-30 to 0 dBm0	\geq 35 dB	\geq 33 dB
-40 dBm0	\geq 29 dB	\geq 27 dB
-45 dBm0	\geq 25dB	\geq 22 dB
Absolute group delay	< 750 microseconds	
Group Delay Distortion vs. frequency	within boundaries of ITU-T Rec. G.713 Figure 2	
Longitudinal Balance	Nominal > 46 dB Typical > 50 dB	
Variation of Gain with Input Level	within boundaries of ITU-T Rec. G.713 Figure 7	

Chapter 13

FXO Card

13.1 Introduction

This chapter provides installation, configuration, and troubleshooting information for the Foreign Exchange - Office (FXO) Card, which is identified as a FXO 2W*8-6 card on its faceplate ejector.

The FXO 2W*8-6 Card manages the flow of FXO voice traffic through the integrated access system. Each card encodes analog (voice, VF) signals to a digital bitstream at the local system for transmission over a T1 or E1 network. It also decodes the digital signals to analog at the remote system.

The card has a two-wire interface and supports Foreign Exchange - Office (FXO), Manual Ringdown (MRD), Foreign Exchange Office-Defined Network (FXODN), and Dial-Pulse Terminating (DPT) operations.

The FXO card also can use the voice compression features of an ADPCM card.

13.2 FXO Card Descriptions

13.2.1 FXO 2W*8-6 Card Description (813970)

The FXO 2W*8-6 Card is a eight-port voice card with a 600-ohm terminating impedance on each port. All FXO features are supported by this card.



Notice!

UL STATEMENT

**OPERATION OF THIS INTERFACE IS LIMITED TO INTRA-BUILDING
CONNECTIONS ONLY**

13.2.1.1 Card Jumper/Switch Settings

The FXO 2W*8-6 Card has eight sets of jumpers that you must set before inserting the card into a system chassis. Figure 13-1 shows these jumpers, which allow you to configure individual ports of the card for either FXO or MRD operation.

To set up a port for MRD operation, insert shorting jumpers vertically between pins 1 and 2 for that port, as shown. Each port has two associated jumpers. To use FXO operation on any port, remove its associated jumpers.

Note that jumper position numbers 1 and 2 are not marked on the card. They are shown in Figure 13-1 for your convenience.

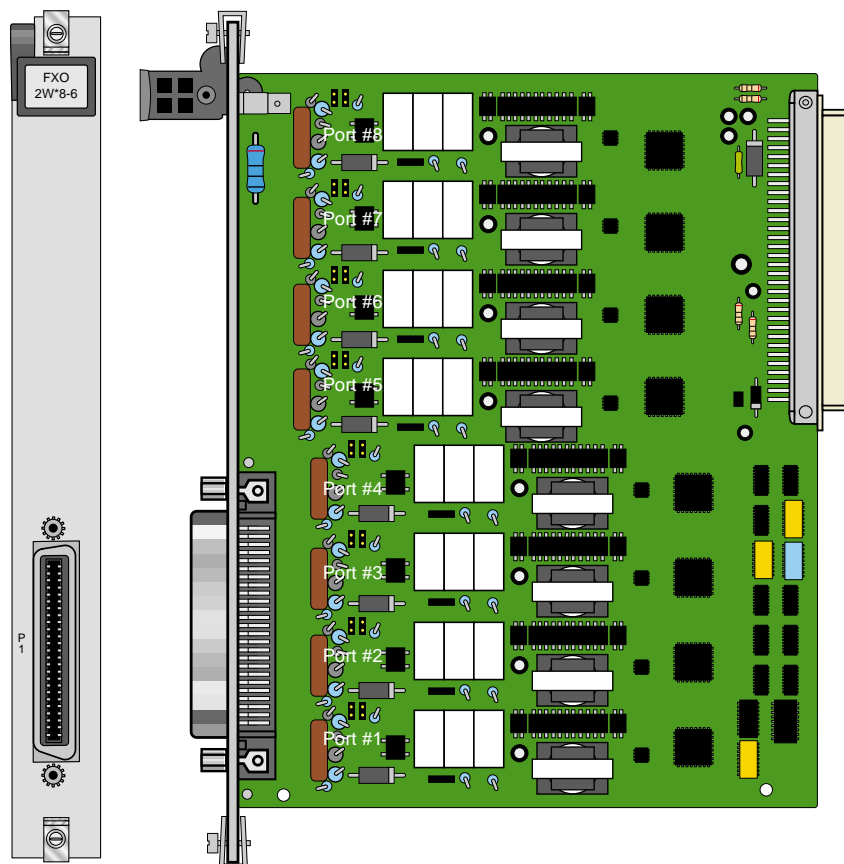

Figure 13-1.FXO 2W*8-6 Card Jumper Settings

13.2.1.2 Installing the FXO 2W*8-6 Card

Install the FXO 2W*8-6 card in any user card slot. These slots are U1 to U8 on the two-sided chassis and front-loading chassis with power supplies on top, or P1 to P4 and W1 to W4 on the front-loading chassis with power supplies on the side.

13.3 FXO Card User Screens and Settings

13.3.1 FXO Card Main Screen

The FXO Card must be configured for operation after installing it into the system chassis. This is done from the FXO Card Main Screen (see Figure 13-2). To go to that screen, highlight the desired card in the System Main Screen and press <Enter>. This screen shows one configuration column for each port on the card.

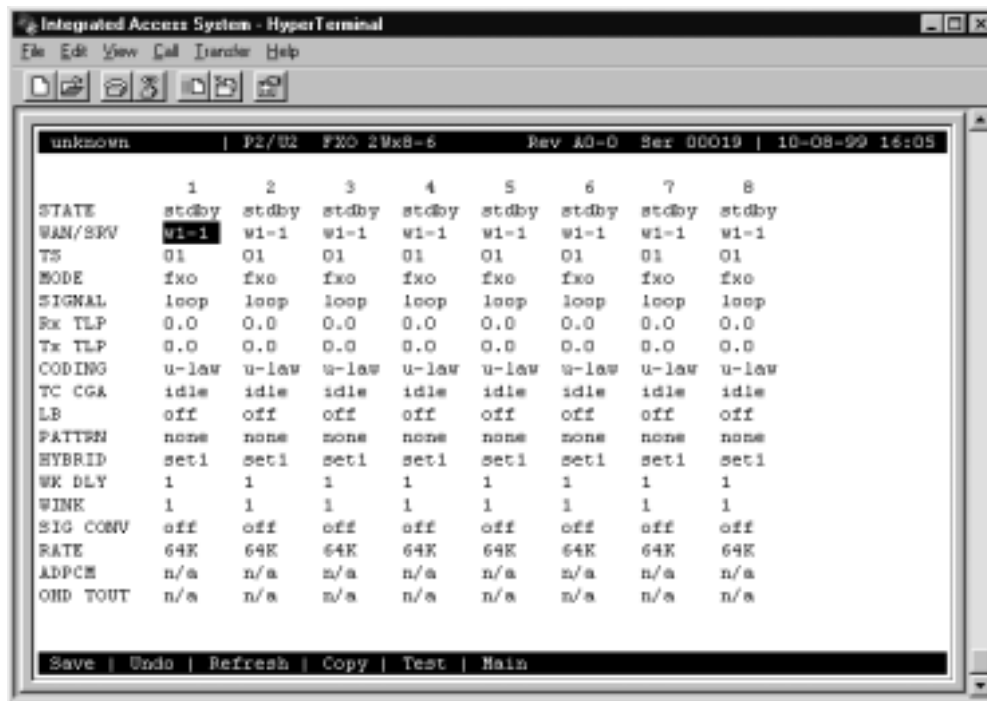

Figure 13-2. Typical FXO Card Main Screen

The bottom highlighted line of this screen shows various actions that you can perform from the screen. You perform the desired action by pressing the associated uppercase letter key. Table 13-1 summarizes these actions. For example, after you configure the FXO card ports, press “s” to save your settings.

Table 13-1. Main Screen Actions

Action	Function
Save	Saves changes to settings.
Undo	Returns all settings to the last saved state.
Refresh	Updates certain time-related information fields that are not automatically updated (i.e., test status).
Copy	Copies the contents of the current column to the next column. Useful if you change a lot of entries in one column and want to repeat those changes in subsequent columns.
Test	Initiates and monitors testing of all FXO card ports. Refer to the Test section of this chapter.
Main	Returns to the System Main Screen. If changes are made to settings and not saved, you will be prompted to save or lose changes.

Table 13-2 summarizes the configuration settings for the FXO card, along with the available and factory-default option settings. The parameters and settings are also described in the following paragraphs.

Table 13-2. Main Screen Option Settings and Defaults

Parameter	User Options	Notes	Default
STATE	stdby actv		stdby
WAN/SRV	none wan serv user	1	w1-1
TS	01-24 01-31	2	01
MODE	fxo fxodn dpt mrd		fxo
SIGNAL	loop gs lp-fd 1s-R2 gs-a lp-em	3	loop
Rx TLP	-10.0 dB to +2.0 dB		0.0
Tx TLP	-10.0 dB to +5.0 dB		0.0
CODING	u-law a-law a-inv	4	u-law
TC CGA	idle busy		idle
LB	off dgtl anlg		off
PATTERN	none D-mW quiet		none
HYBRID	set1 to set8 user	5	set1
WK DLY	00-99	6	0
WINK	00-199	6	0
SIG CONV	off on		off
RATE	64K 24K,1 32K,1 40K,1 24K,2 32K,2 40K,2	7	64K
ADPCM	n/a P1 P2 P3		n/a
OHD TOUT	1600ms - 3300ms	8	3300ms

Notes:

1. Choosing **wan** allows you to choose a WAN port (w1-1 through w4-2). Choosing **serv** lets you choose an ADPCM server card in slot P1, P2, or P3, followed by a logical port on that card. *If your system has the FRS card installed and you want to use voice compression you need to install the Low Bit Rate Voice (LBRV) card. However, if your system has the ATM card installed you can proceed directly with voice compression (there is no need for the LBRV Card to be installed.)* The **user** option is not used. See the WAN/SRV paragraph that follows.

2. Time slot 16 is not available if the port is assigned to an E1 WAN link whose time slot 16 is programmed for **CAS** or **CCS**.
3. These options are only valid if the Mode selected is **fxo**, or **fxodn**. If the mode is **dpt**, then the Signal options are **dpt** (default), **R2**, **i-R2** or **dp-em**. If the Mode is **mrd**, then the Signal setting will automatically default to **mrd**. CallerID can be activated or deactivated using the SIGNAL configuration for each port. For more information on CallerID, refer to “SIGNAL” on page 6.
4. The default is **a-inv** for E1 and **m-law** for T1. These values will change depending upon the WAN link selected.
5. The default, **set1**, is the only active option. It balances to the ideal termination of 600 ohms + 2.15 uF. The other settings are reserved for future use.
6. These settings should be used with **fxodn** and **dpt** modes only.
7. Choosing a Rate other than **64K** allows you to select an ADPCM slot.
8. This option can be edited only when OHD signal type is selected. This value can have a range of 1600ms - 3700ms. This value tells how long the system should be in ONHOOKDATA state. This is a user-defined value to accommodate different ring cadence. The default value is **3700ms**.

STATE

The State setting determines whether the port is active or inactive. An inactive port does not occupy a time slot on a WAN link. Set the State setting to standby (**stdby**) for ports you are not using or have not yet configured. Set it to active (**actv**) for ports that are ready for use.

WAN/SRV

The WAN/SRV setting identifies the WAN link or server card assigned to this port. If you choose **wan**, you also must select the desired port (w1-1 through w4-2) of a WAN card for transmission over a T1 or E1 link. Or, choose **serv** to assign the card port to a server card in the system. This can be an ATM or FRS card, which resides in chassis slot P1, P2, or P3. You must then choose a logical port on that card. The **user** option is not used.

It is not necessary to assign all ports of the same FXO card to the same WAN link or server card, or to contiguous time slots on a WAN link.

TS

The TS setting identifies the time slot on the WAN link to which this port is assigned. Values range from **1-24** for T1 links and **1-31** for E1 links. Time slot 16 is not available on E1 links that are programmed for **cas** or **ccs** signaling. For a display of the available time slots, refer to your cross-connect map for the WAN link.

MODE

The Mode setting should be determined by the type of equipment to which you connect the port. All options use two-wire balanced connections. The **fxo** (Foreign Exchange Office) option allows you to connect the system to a 2 way PBX trunk (both inbound and outbound calls) or a key system trunk. The **fxodn** (Foreign Exchange Office-Defined Network) option provides access to new services offered by advanced networks from many major carriers. The **dpt** (Dial Pulse Terminating) option allows the unit to attach to incoming one-way trunks from a PBX, key system, or a telephone set. This option is similar to the **fxo** option.

The **mrd** (manual ringdown) option provides point-to-point unswitched connections between two telephone sets. This configuration is usually not attached to an exchange or switch; rather it provides a “hot line” between two locations. *The system requires hardware changes and a ringing generator for this option (see instructions later in this chapter).*

SIGNAL

The Signal setting matches the signaling behavior of the FXO equipment and the remote switch. Use the **loop** (Loop Start) option with telephone sets and simple PBX trunks. Use the **gs** (Ground Start) option with two-way PBX trunks because it helps to prevent glaring or call collisions. Use the **lp-fd** (Loop Start–Forward Disconnect) option with automated answering equipment. The **R2** option is provided for a CCITT R2 interface. The selection you choose must match the behavior of the station equipment and the remote central office or PBX equipment. Use **gs-a** (ground-start automatic) for equipment requiring fast-response time to the central office. Use the **lp-em** option for (Loop Start). Use the **ohd** option for On-Hook Data Data Transmission between first and second ring (example: CallerID). The selection must match the behavior of both the station equipment and remote central office or PBX. The **ohd** option is limited in its capabilities. If the line goes off-hook before or during the data transmission, data transmission shall be pre-empted or stopped and normal call completion treatment shall be provided. There should be at least a 5 second delay between two different phone calls so that the integrated access system can distinguish between 2 different phone calls and silence between ringing pattern of one call.

If you selected the **dpt** option for the Mode of any port, then the three options that are supported under Signal are **dpt** for standard Dial Pulse Termination signaling used in North America, **R2** for CCITT signaling used internationally, **i-R2** (immediate R2) which provides immediate seizure acknowledgment to the network and **dp-em** (Dial Pulse

Electromechanical) used for timing relays that are specific to Russia. If you selected **mrd** as the Mode, then Signal will automatically default to **mrd**. If you select **fxodn** in Mode the options are **loop**, **gs**, **lp-fd**, **R2**, **gs-a** and **lp-em**. For **fxo** the additional option is **ls-R2**.



CAUTION!

Before activating a port, verify the behavior expected by both the station equipment and the remote central office equipment and ensure that you have the system properly configured.

Rx TLP

The Receive Transmission Level Point setting controls the amount of gain or attenuation added to signals after they are decoded to analog signals. To increase the signal level, set the Rx TLP setting to a positive number (i.e., the larger the number, the more gain is added). To decrease the signal level, set the Rx TLP setting to a negative number (i.e., the more negative the number, the more the signal level is decreased). For example, an incoming signal at -5 dBm can be increased to -3 dBm by setting Rx TLP to +2 dB. Acceptable values range from **-10.0 dB to +2.0 dB**.

Tx TLP

The Transmit Transmission Level Point setting controls the amount of gain or attenuation added to signals after they are received from the local analog port and before they are encoded to digital PCM signals. To increase the signal level, set the Tx TLP setting to a negative number (i.e., the more negative the number, the more gain is added). To decrease the signal level, set the Tx TLP setting to a positive number (i.e., the more positive the number, the more the signal level is decreased). For example, an incoming signal at -5 dBm can be increased to -2 dBm by setting Tx TLP to -3 dB. Acceptable values range from **-10.0 dB to +5.0 dB**.

CODING

The Coding setting sets the PCM companding method used for a port. Generally, the North American T1 environment uses **m-law** coding. The International E1 environment uses **a-law** or **a-inv** (inverted A-law) coding, and **a-inv** provides a higher ones density than **a-law**. The coding default is determined by the type of card in the WAN port you select.

TC CGA

The Trunk Conditioning during Carrier Group Alarm setting defines whether the FXO port should be placed in **idle** or **busy** mode upon declaration of a Carrier Group Alarm (CGA) on the WAN link to which the port is assigned. In most cases, you should set this parameter to

busy. If a call is in progress when the CGA alarm is received, the system will hold the call for two seconds, drop it and then busy out the port to the attached PBX for the duration of the alarm. Once the alarm clears, the system will automatically place the port back in **idle** mode thereby making it available to the attached PBX.

LB

The Loopback field lets you loop the port back toward the network and far end. The **dgtl** (digital) loopback sends the incoming digital DS0 signal back to the far end without decoding it. The **anlg** (analog) loopback sends the decoded analog signal back to the far end after decoding and then re-encoding it. Figure 13-3 shows the loopback options, which allow you to test and troubleshoot the FXS card. To disable a loopback, set this field to **off**.

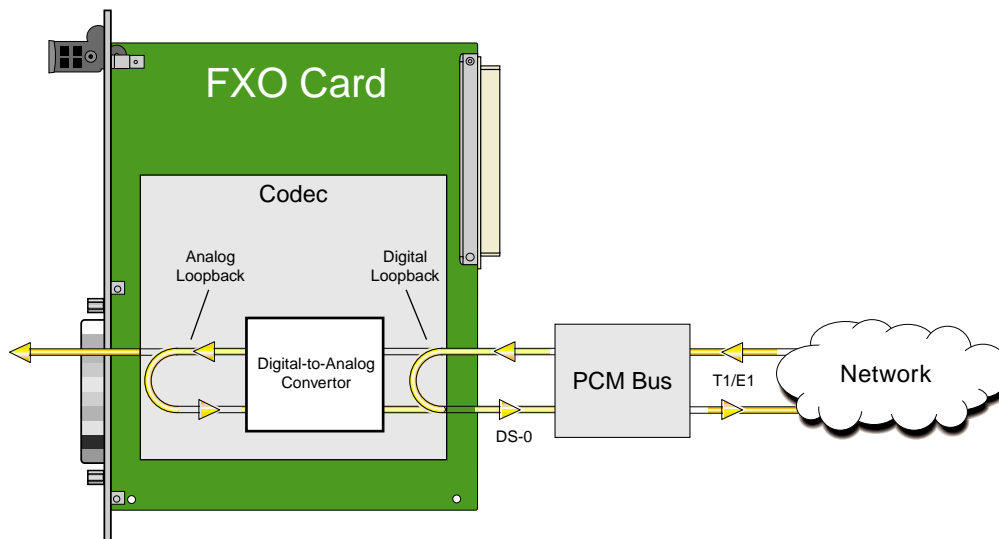

Figure 13-3.FXO Card Loopbacks

PATTRN

The Pattern setting sets the outgoing test pattern for this analog port. The pattern, generated by the system, is sent only to the currently selected port. The **none** option disables sending a test pattern. The **D-mW** (Digital milliwatt) option sends a 1 kHz tone at 0.0 dBm. The Rx TLP setting affects the D-mW signal level. The **quiet** option places a termination on the line so that no analog signal is sent.

HYBRID

The Hybrid option assigns a three-byte pattern to define the adjustment for return loss (similar to Build-Out Capacitors). The default, **set1**, balances to the ideal termination of 600 ohms + 2.15 uF. The other settings are reserved for future use.

WK DLY

The Wink Delay setting allows you to set the wink delay time. The options are units of 100 milliseconds. Settings are **1-99** (100 milliseconds to 9.9 seconds). The Wink Delay and Wink options are applicable to CCITT systems for determining the delay of the R2 state machine. They should only be used with modes **fxodn** and **dpt (R2 and i-R2)**.

WINK

The Wink setting allows you to set the wink duration time. The options are units of 100 milliseconds. Settings are **1-99** (100 milliseconds to 9.9 seconds). This option is only applicable with modes **fxodn** and **dpt (R2 and i-R2)**.

SIG CONV

The Signaling Conversion parameter allows you to change the ABCD signaling bits from CCITT (E1) to ANSI (T1) standards. This conversion is completed regardless of the type of WAN aggregate (CSU/DSX **or** CEPT) to which it is attached. The options are **off** (which means that ANSI signaling is used) and **on** (which converts transmit signaling from ANSI to CCITT format according to the Interface Card Conversion Table for FXO signaling, and also converts receive signaling from CCITT to ANSI).

RATE

The Rate parameter allows you to use the voice compression capabilities of the ADPCM resource card. If that card is not present in the system, changes cannot be made to this setting. The **64K** option (default) does not use ADPCM resources (it is the normal operation rate for voice circuits).

ADPCM voice channels are assigned in pairs by designating two voice ports (E&M, FXO or FXS) to the same WAN link and time slot and selecting rate settings for the pair that add up to 64kbps (i.e. [24K,1+40K,2],[32K,1+32K,2] and [40K,1+24K,2]). The numeral 1 after the rate setting assigns that portion of the voice port pair to the odd side of the ADPCM pair. The numeral 2 after the rate setting assigns that portion of the voice port pair to the even side of the ADPCM pair.

For more information about voice port assignments to the ADPCM card, please consult the ADPCM section of the manual.

ADPCM

The ADPCM parameter lets you choose the ADPCM card on which to place this FXO port. The default setting is **n/a** and only changes when a Rate smaller than **64k** is selected (see above). You can then select which ADPCM card to use for the port (assignment is made by chassis slot number). The options are **P1**, **P2**, and **P3**.

OHD TOUT

The On-Hook Data Timeout parameter lets you choose a value range of 1600ms - 3300ms. This value tells how long the system should be in ONHOOKDATA state. The default value is **3300ms**.

13.3.2 Test Screen

The Test option facilitates testing and maintenance by allowing you to monitor and set the status of the analog interface leads as well as monitoring and setting the value of the A, B, C and D signaling bits of all FXO circuits on that card. In cross-connect systems only, the test option also allows you to apply test patterns and tones towards the user and network sides of the system.

Figure 13-4 shows a typical FXS Card Test Screen, Table 13-3 lists some actions you can perform from this screen, and Table 13-4 shows the option settings and defaults for each parameter.

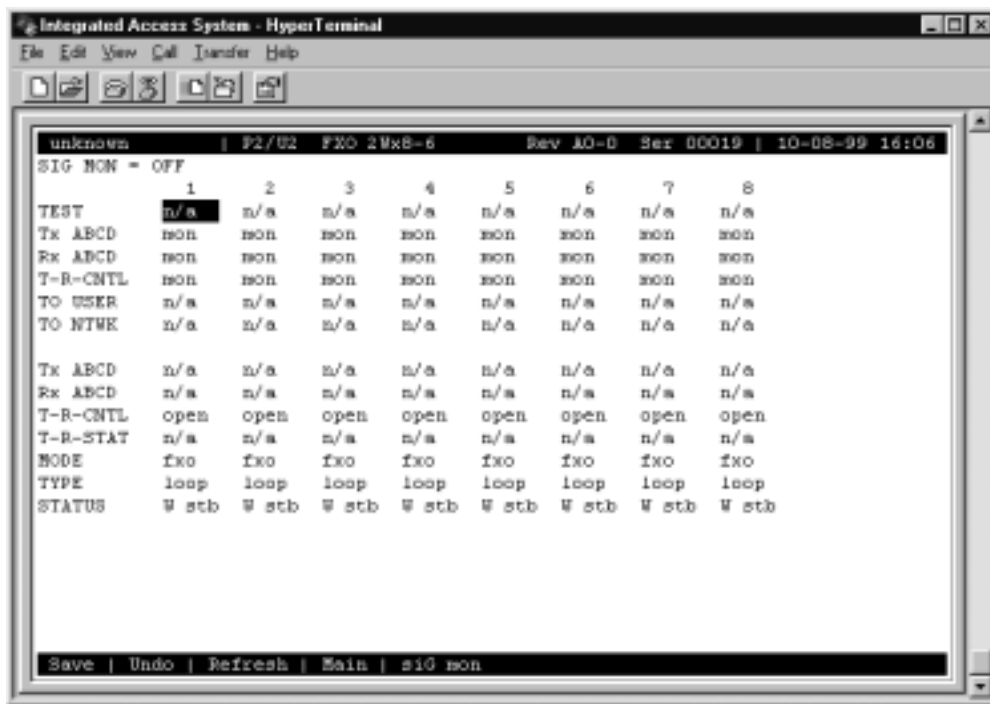

Figure 13-4. Typical FXO Card Test Screen

Table 13-3. Test Screen Actions

Action	Function
Save	Saves changes to settings.
Undo	Returns all settings to the last saved state.
Refresh	Updates certain time-related information fields that are not automatically updated (i.e., test data).
Main	Returns to the FXO Card Main Screen. If changes are made to settings and not saved, you will be prompted to save or lose changes.
siG mon	Used with the user card alarm system to notify you of excessive transitions of signaling bits.

Table 13-4. Test Screen Option Settings and Defaults

Parameter	User Options	Default
SIG MON	off on	off
TEST	off on	off
Tx ABCD	mon set	mon
Rx ABCD	mon set	mon
T-R-CNTL	mon set	mon
TO USER	PCM 300Hz 1kHz 3kHz quiet	PCM
TO NTWK	PCM 300Hz 1kHz 3kHz quiet	PCM
Tx ABCD	Status information only; not editable	n/a
Rx ABCD	Status information only; not editable	n/a
T-R-CNTL	Status information only; not editable	n/a
T-R-STAT	Status information only; not editable	n/a
MODE	Status information only; not editable	n/a
TYPE	Status information only; not editable	n/a
STATUS	Status information only; not editable	n/a

SIG MON

The Signaling Monitor feature works with the user card alarm system to detect excessive signaling bit transitions. The system will generate alarms if the number of transitions of any signaling bit in transmit or receive direction for an active port exceeds 255 in any four second interval. The options are **off** and **on**, and they are toggled by pressing “g” (**siGmon** command) in the Test Screen.

TEST

The Test Parameter shows if the port is in the test mode or not. Inactive ports and ports that are assigned to inactive WANs will show a test status of **n/a**. The test status options for active ports are **off** and **on**.

Tx ABCD

The Transmit ABCD setting allows you to either monitor the status of the ABCD signaling bits being transmitted towards the network or set a specific ABCD pattern for testing the transmit side of the circuit. The options for this field are **mon** (monitor) or **set**. Choosing **set** will bring up a four digit field for you to input the ABCD pattern you want to transmit. Any four digit combination of ones and zeros is acceptable for this setting.

Rx ABCD

The Receive ABCD setting allows you to either monitor the status of the ABCD signaling bits being received from the network or set a specific ABCD pattern for testing the receive side of the circuit. The options for this field are **mon** (monitor) or **set**. Choosing **set** will bring up a four-digit field for you to input the ABCD pattern you want to receive. Any four digit combination of ones and zeros is acceptable for this setting.

T-R-CNTL

The Tip and Ring Control setting allows you to either monitor (**mon**) or set (**set**) the state of the Tip and Ring leads of an FXO port. Choosing **set** will bring up the following options:

- **loop** (the Tip and Ring leads are tied together)
- **open** (the Ring lead is not connected to either Tip or ground)

TO USER

In cross-connect systems only, the To User parameter allows you to break the circuit and send a 0dB test tone toward the user side of the system. The options for this field are **PCM**, **300Hz**, **1 kHz**, **3 kHz** and **quiet**. Selecting **PCM** means that you do not want to inject a tone toward the user and that the PCM signal received from the network should continue to be sent to the user port in the normal manner.

TO NTWK

In cross-connect systems only, the To Network parameter allows you to break the circuit and send a 0dB test tone toward the network side of the system. The options for this field are **PCM**, **300Hz**, **1 kHz**, **3 kHz** and **quiet**. Selecting **PCM** means that you do not want to inject a tone toward the network and that the PCM signal received from the user port should continue to be sent to the network in the normal manner.

Tx ABCD

The Transmit ABCD information field shows the current values of the ABCD bits that are being transmitted to the network. If TX ABCD in the top half of the screen is changed via the **set** function mentioned above, and the settings are saved by the Save command in the Menu of Actions, the new bit pattern chosen will be reflected here.

Rx ABCD

The Receive ABCD information field shows the current values of the ABCD signaling bits that are received from the network. If RX ABCD in the top half of the screen is changed via the **set** function mentioned above, and the settings are saved by the Save command in the Menu of Actions, the new bit pattern chosen will be reflected here.

T-R-CNTL

The Tip and Ring Control information field shows the current status of the Tip and Ring leads of the FXO port from the perspective of the system. The possible values are:

- **loop** (the Tip and Ring leads are tied together)
- **open** (the Ring lead is not connected to either the Tip or to ground)
- **rgnd** (the Ring lead is grounded)
- **lpgnd** (the Tip and Ring leads are tied together and the Tip is grounded)
- **ring** (ringing voltage is being applied between the Tip and Ring)

T-R-STAT

The Tip and Ring Status information field describes what the attached device is doing with the Tip and Ring leads of the FXO port. The possible values are:

- **ring** (attached device is applying ringing voltage between Tip and Ring)
- **TbRg** (attached device is applying -48V battery to Tip and grounding Ring)
- **ToRo** (attached device is leaving both the Tip and Ring leads open)
- **TgRo** (attached device is grounding the Tip lead and is leaving the Ring lead open)
- **RbTg** (attached device is applying -48V battery to Ring and grounding Tip)
- **RbTo** (attached device is applying -48V battery to Ring and leaving Tip open)
- **TgR*** (attached device is grounding Tip, and the Ring lead state is unknown)
- **ToR*** (attached device is leaving Tip open, and the Ring lead state is unknown)
- **RoT*** (attached device is leaving Ring open, and the Tip lead state is unknown)
- **n/a** (information is not available)

MODE

The Mode information field shows the current mode of the port that was selected on the main FXO card Screen. Valid settings are **fxo**, **fxodn**, **dpt** or **mrld**.

TYPE

The Type information field shows the current status of the signal field selected on the main FXO card screen for this port. Valid settings for both **fxo** and **fxodn** modes are **loop** (loop), **gs** (ground start), **lp-fd** (loop start-forward disconnect) and **R2** (R2). Valid settings for the **dpt** mode are **dpt** (dial pulse terminating), **R2** (R2), **i-R2** (immediate R2), and **dp-em** (Dial Pulse Electromechanical). The only valid setting for the **mrd** mode is **mrd** (manual ringdown).

STATUS

The Status information field shows the current status of the port Table 13-5 lists and describes all of the possible conditions that are reported in this field.

Table 13-5. Status Information Field Settings

Setting	Meaning
stdby	The FXO port is in standby.
W stb	The WAN card to which the FXO port is assigned is in standby.
W tst	The WAN card to which the FXO port is assigned is under test.
W OOS	The WAN card to which the FXO port is assigned is out of service.
noWAN	No WAN card is configured in the slot to which the FXO port is assigned.
call	Call setup is in progress.
busy	Call is in progress.
idle	No call in progress (port is available for a call).
TC	Port is in Trunk Conditioning because a CGA alarm occurred on the associated WAN port.
test	Port is under test (i.e., you are actively controlling the circuit by setting values for Tx ABCD or Rx ABCD).
maint	The port is in a maintenance condition.

13.4 FXO Card Error Messages

Refer to Appendix B in the System Reference Guide for further information on Error Messages regarding this card.

13.5 FXO Card Troubleshooting

The FXO card may be faulty if a voice signal is not received at one end of a circuit, or if signaling is not detected. The following are possible causes:

- Faulty receiving CPE at the near end (where the problem was first noticed)
- Faulty transmitting CPE at the far (opposite) end
- Faulty cabling between the CPE and FXO card at the near end
- Faulty cabling between the CPE and FXO or FXS card at the far end
- T1 or E1 network failure
- Improper card configuration at either end (e.g., time slot and/or WAN port assignments)

First, verify that the T1 or E1 network has not failed. Check for a CGA-Red alarm on the associated WAN port at the end where the incoming VF signal loss is first noticed. The CGA indicates that the incoming network signal was lost (or that the receiving WAN port is out of frame). During the CGA, all voice ports with time slots on that WAN port will also be disabled, and the associated far-end WAN port will be in a CGA-Yellow alarm state. If the network is faulty, you must clear that trouble to restore your circuits.

If the network is okay, verify that the proper WAN ports and time slots are assigned to the associated FXO and FXS voice ports at both ends, as previously outlined in this chapter. In a point-to-point network, the near-end and far-end FX card ports should both be assigned the same WAN port and time slot number. Also make sure the other parameters (such as the transmit and receive TLPs) are set properly at both ends.

If the FX card port parameters are correct at both ends, and if the network is okay, the trouble is isolated to the FXO card or the associated port. Proceed as follows:

1. At the far end, activate an analog loopback on the FX card port.
2. Send a 0 dBm (digital milliwatt) test signal toward the CPE at that end. That signal will be substituted for the normal signal coming from the far-end CPE; it will be sent back to the CPE at your end via the loopback path.
3. Check your CPE for this signal. If it is present, the far-end CPE or cabling to the far-end FX card is probably faulty. Disable the loopback and test signal there, and fix the problem. If you still don't receive a signal, go to step 4.

4. At your end, go to the FXO Card Main Screen and send a digital milliwatt test tone (0 dBm) toward the CPE. If you still don't receive a signal, check the cabling from the FXO card to your CPE, and check the CPE itself. If those items are okay, replace the FXO card at your end.

5. If the FXO card is determined to be faulty, replace it and return the faulty unit for repair to the location specified by your distributor.

13.6 FXO Card Specifications

FXO Card (813970 2-wire)		
Number of Ports		
Models 813970	8 ports	
Physical Interface		
Connector	1 female 50-pin telco connector	
Transmission Performance		
Performance	Exceeds requirements of ITU-T Rec. G.713	
Signaling Modes		
Model 813X Signaling Modes	Software selectable on a per port basis Foreign Exchange Office (FXO) Ground Start Foreign Exchange Office- Defined Network (FXSDN) Manual Ringdown (MRD) Dial Pulse Termination (DPT)	
Termination Impedance		
Model 813970	600 Ohms with 2.16 μ F	
VF Transmission Characteristics		
Nominal Transmit TLP	-10.0 dB to +5.0 dB in steps of 0.1 dB	
Nominal Receive TLP	-10.0 dB to +2.0 dB in steps of 0.1 dB	
PCM Encoding	Software selectable on a per port basis	
Attenuation Versus Frequency Relative to 1 kHz with 0 dBm0 input		
Frequency	Transmit (A to D)	Receive (D to A)
200 Hz	-0.25 to +3.0 dB	-0.25 to +2.0 dB
300 to 3000 Hz	-0.25 to +0.5 dB	-0.25 to +0.5 dB
3200 Hz	0.25 to +0.75 dB	-0.25 to +0.75 dB
3400 Hz	-0.25 to +1.5 dB	-0.25 to +1.5 dB
Return Loss (at 1 kHz)	\geq 28 dB	
Transhybrid Loss	34dB	
Idle Channel Noise (rcv and xmt)	< -65 dBm0p Typical < -70 dBm0p or < 20 dBrcn0	
Interchannel Crosstalk	Typical < -75 dBm0 using 7 adjacent channels being disturbed with a signal of 0.0 dBm0	
Total Distortion including Quantization (Signal to Distortion Ratio) Input Frequencies 1004-1020 Hz		
Input Level	Rcv or Xmt	Overall
-30 to 0 dBm0	\geq 35 dB	\geq 33 dB
-40 dBm0	\geq 29 dB	\geq 27 dB
-45 dBm0	\geq 25dB	\geq 22 dB
Absolute group delay	< 750 microseconds	
Group Delay Distortion vs. frequency	within boundaries of ITU-T Rec. G.713 Figure 2	
Longitudinal Balance	Nominal > 46 dB Typical > 50 dB	
Variation of Gain with Input Level	within boundaries of ITU-T Rec. G.713 Figure 7	

Chapter 14

Data Cards

HSU Card

14.1 Introduction

This chapter provides installation, configuration, and troubleshooting information for the High-Speed Data Unit (HSU) Cards. These cards are labeled as follows on their faceplate ejectors: Two-port HSU 530/35 (820260), HSU-T V11 (820360), HSU 35 (821260), HSU-AD 530/35 (821360), HSU-T V35 (821460), Four-port HSU 530/35 (821570) and the HSU*4E 530/35 SS (821660). This chapter also provides information for the Personality Modules used with some of these cards.

The HSU Cards allow you to connect high-speed data terminal equipment (DTE) and/or data communications equipment (DCE) to WAN links, resource cards, and/or other HSU cards.

14.2 HSU Card Description

14.2.1 Two-Port HSU530/35 Card Description (820260)

The two-port HSU 530/35 Card supports two RS-530 or RS-449 CPE data devices. It can also support V.35 and RS-232 data when used with personality modules, which are described later in this chapter.

14.2.1.1 Two-Port HSU Card Jumper/Switch Settings

The HSU 530/35 Card has two slide switches that you must set for either RS-530 or V.35 interfacing on its data ports. Figure 14-1 shows these switches, which are factory-set to RS-530 operation (up positions) for both ports. To change a card port for V.35 operation, reset its associated switch to the down position.

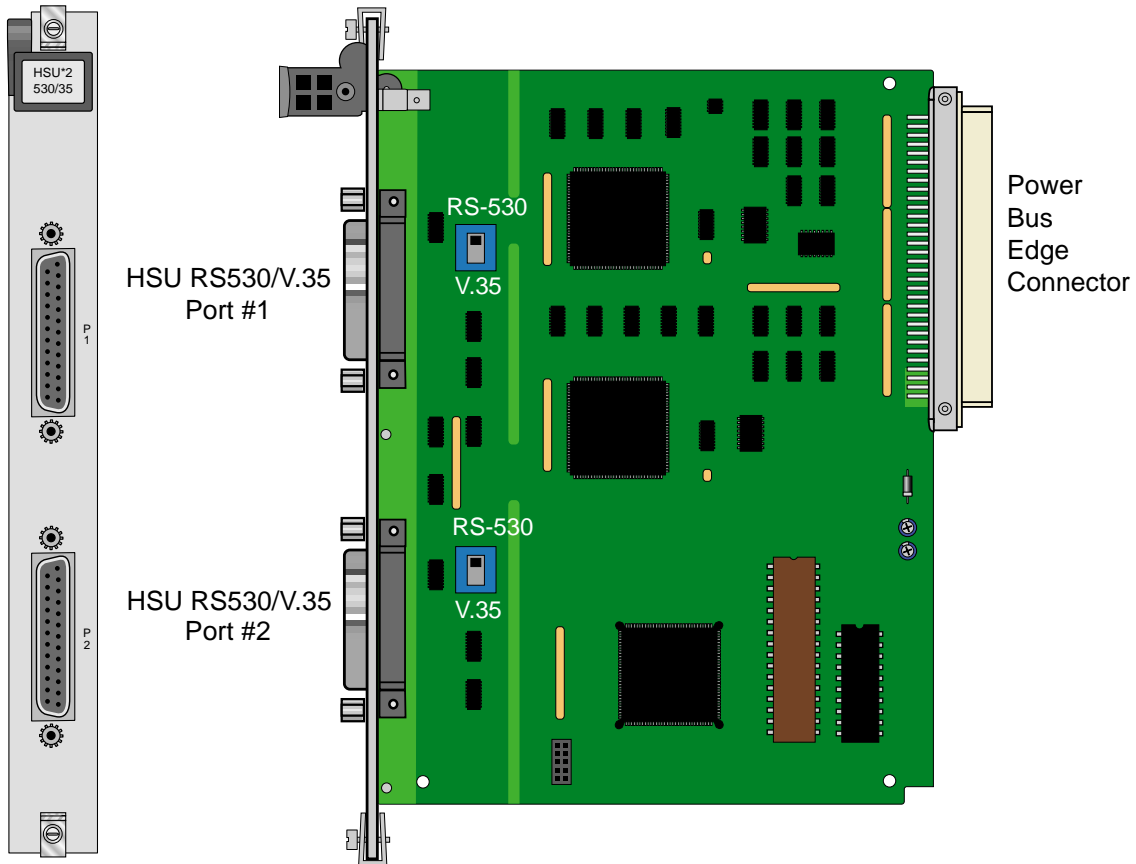

Figure 14-1. Two-Port HSU 530/35 Card Switches

14.2.1.2 Installing the Two-Port HSU 530/35 Card

Install the Two-Port HSU 530/35 Card into any user card slots. These slots are U1 to U8 on the two-sided chassis and front-loading chassis with power supplies on top, or P1 to P4 and W1 to W4 on the front-loading chassis with power supplies on the side.

14.2.2 HSU-T V11 Card Description (820360)

The HSU-T V11 Card has two ports that connect to RS-530 or X.21 CPE devices. Each port can operate as either DCE or DTE, with data speeds ranging from 56 or 64 kbps to 1.536 or 1.984 Mbps.

14.2.2.1 HSU-T V11 Card Jumper/Switch Settings

The HSU-T V11 Card main board does not contain any jumpers or switches.

14.2.2.2 Installing the HSU-T V11 Card

Install the HSU-T Card into any user card slots. These slots are U1 to U8 on the two-sided chassis and front-loading chassis with power supplies on top, or P1 to P4 and W1 to W4 on the front-loading chassis with power supplies on the side.

14.2.3 HSU 35 Card Description (821260)

The HSU 35 Card supports two V.35 data ports.

14.2.3.1 HSU 35 Card Jumper/Switch Settings

The HSU 35 Card doesn't have any jumpers or switches on its mainboard.

14.2.3.2 Installing the HSU 35 Card

Install the HSU 35 Card into any user card slots. These slots are U1 to U8 on the two-sided chassis and front-loading chassis with power supplies on top, or P1 to P4 and W1 to W4 on the front-loading chassis with power supplies on the side.

14.2.4 HSU-AD 530/35 Card Description (821360)

The HSU-AD 530/35 Card supports two RS-530 or V.35 CPE devices. The selection of RS-530 or V.35 is made on a port-by-port basis using on-board switches as described below. This card also supports V.25bis dialing (an inband dialing protocol) and RS-366 dialing through separate DB-15 RS-366 jacks on the card. The HSU-AD 530/35 Card also has a proprietary inband performance monitoring system.

14.2.4.1 HSU-AD Card Jumper/Switch Settings

Set the card switches for operation of ports 1 and 2 in either the RS-530 or V.35 mode. These switches are shown in Figure 14-2; they are factory-set for RS-530 operation. To change a port to V.35 operation, reset its switch as shown. The ports can be set individually for either RS-530 or V.35 operation, but once you set them, they remain in that mode until the slide switches are reset. RS366 Dialing Port #1 and RS366 Dialing Port #2 are dialing ports for Port #1 and Port #2 (HSU RS530/V.35) respectively; they serve no other purpose.

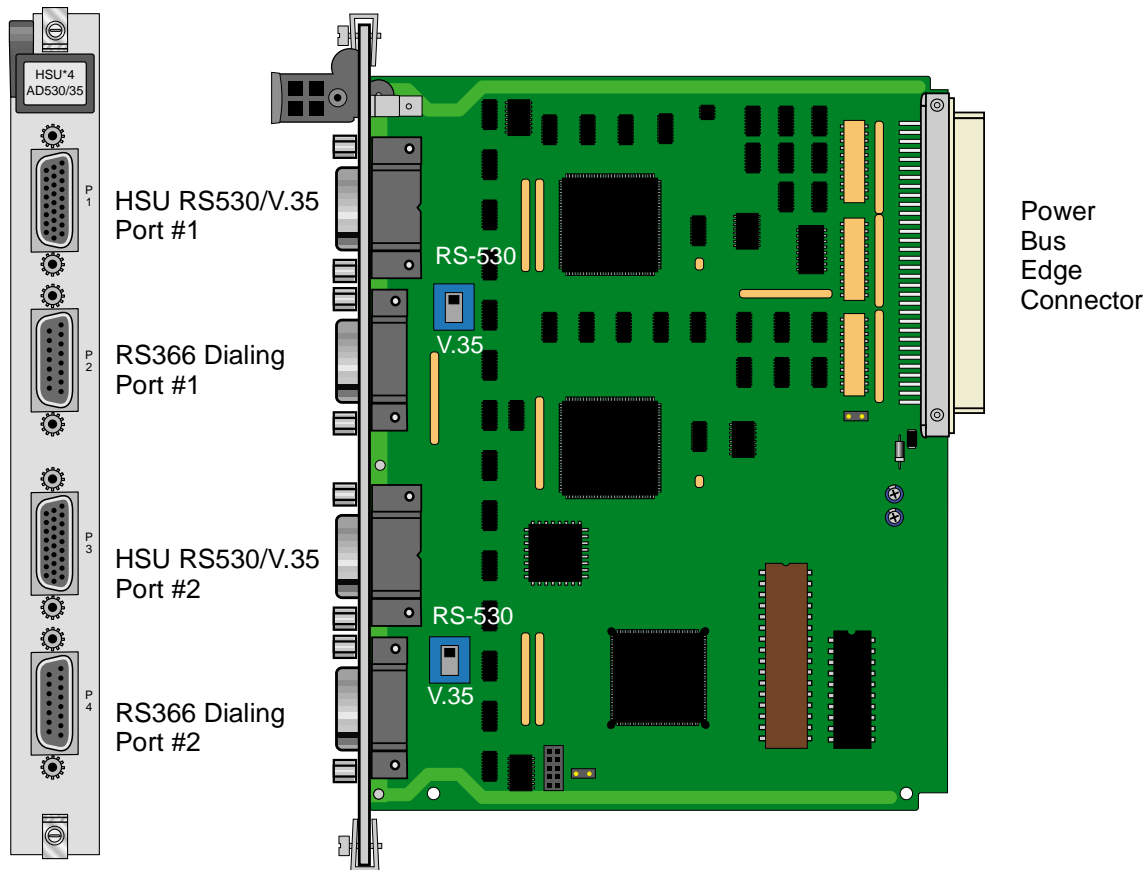

Figure 14-2.HSU-AD 530/35 Card Switches

14.2.4.2 Installing the HSU-AD 530/35 Card

Install the HSU-AD 530/35 Card into any user card slots. These slots are U1 to U8 on the two-sided chassis and front-loading chassis with power supplies on top, or P1 to P4 and W1 to W4 on the front-loading chassis with power supplies on the side.

14.2.5 HSU-T V35 Card Description (821460)

The HSU-T V35 Card supports two V.35 CPE data devices. Each card port can be configured to operate as either DCE or DTE, with data speeds ranging from 56 or 64 kbps to 1.544 or 2.048 Mbps.

14.2.5.1 HSU-T V35 Card Jumper/Switch Settings

The HSU-T V35 Card must be set either to U.S. or European configuration by moving a jumper located on JP3. Figure 14-3 shows this jumper. Setting the jumper on the left two pins establishes the U.S. voltage configuration. Setting it on the right two pins establishes the European voltage. This setting should match the configuration of your particular chassis, or the card will not operate properly. The factory default setting is **US**.

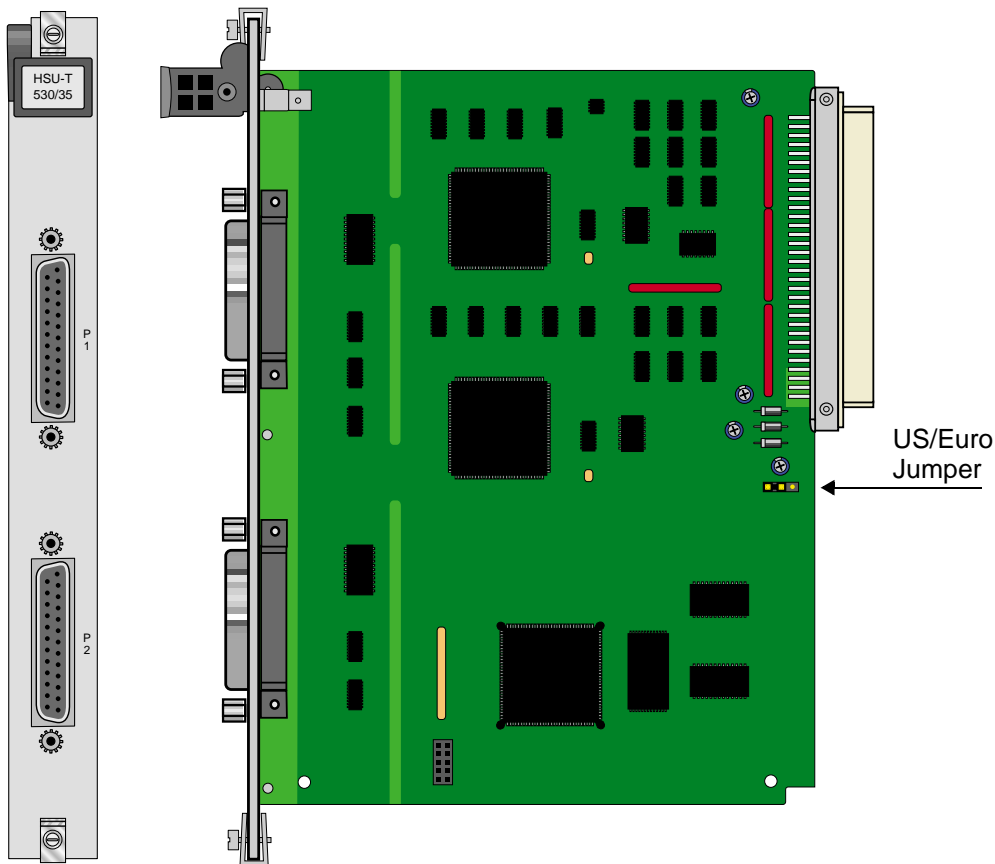

Figure 14-3.HSU-T V35 Card

14.2.5.2 Installing the HSU-T V35 Card

Install the HSU-T V35 Card into any user card slots. These slots are U1 to U8 on the two-sided chassis and front-loading chassis with power supplies on top, or P1 to P4 and W1 to W4 on the front-loading chassis with power supplies on the side.

14.2.6 Four-Port HSU 530/35 Card Description (821570)

The four-port HSU 530/35 Card supports four RS530 or V.35 data ports. The selection of RS-530 or V.35 is made on a port-by-port basis using on-board switches.



CAUTION!

If used in a system using a T1 “Line Code” other than “B8ZS,” HSU card ports assigned to multirate circuits greater than or equal to 4 or more consecutive time slots at 64kbps must have DTE connected to the port prior to activation. Failure to attach DTE will cause a false carrier alarm.

14.2.6.1 Four-Port HSU Card Jumper/Switch Settings

The four-port HSU 530/35 Card has four slide switches that must be set for the proper type of interface (either RS-530 or V.35) on ports 1 through 4 of the card. Figure 14-4 shows these switches, which are factory-set for RS-530 operation on both ports. To change a port for V.35 operation, reset its associated switch as shown. Ports can be set individually for either RS530 or V.35 operation, but once set, they remain in that mode until the slide switches are reset.



Note: When setting switch to V.35 mode it unbalances the CTS Lead. It does not change the voltage levels of the driver output. (The Personality Module will do the same thing as setting the switch).

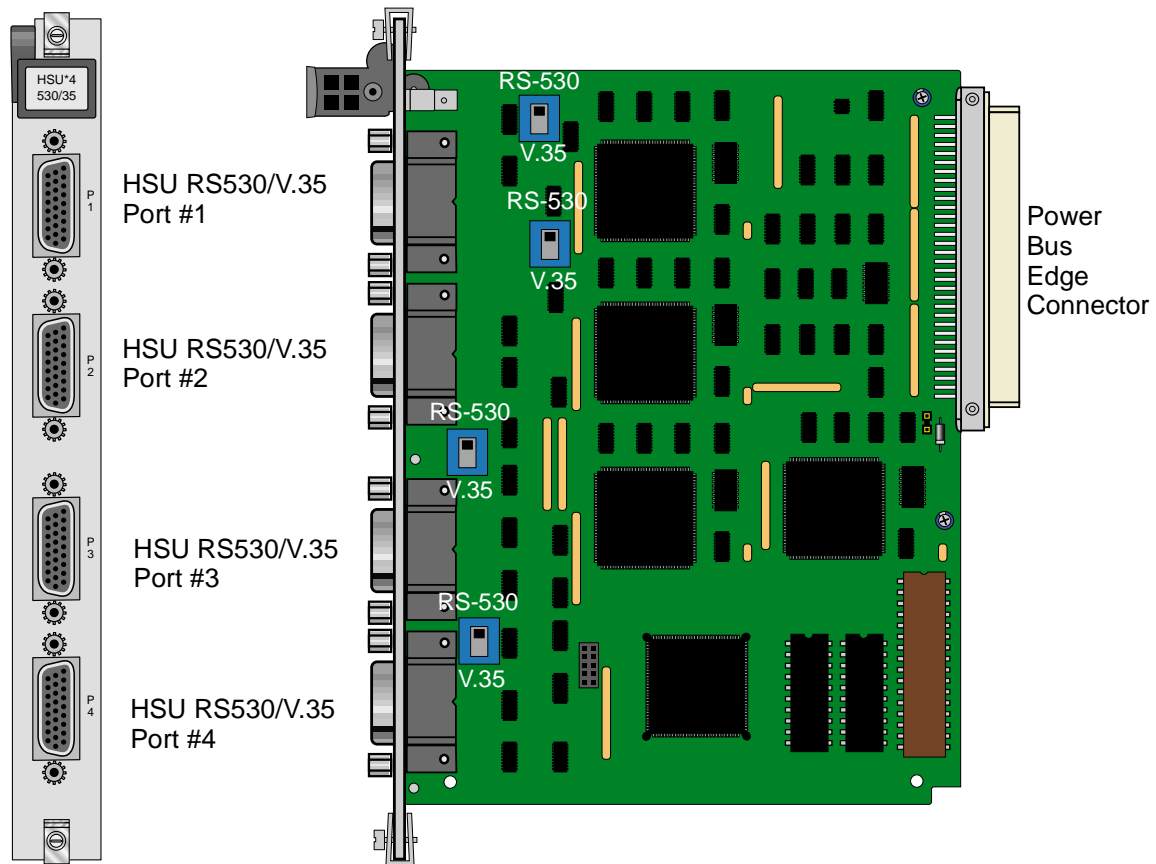

Figure 14-4. Four-Port HSU 530/35 Card Switches

14.2.6.2 Installing the Four-Port HSU 530/35 Card

Install the Four-Port HSU 530/35 Card into any user card slots. These slots are U1 to U8 on the two-sided chassis and front-loading chassis with power supplies on top, or P1 to P4 and W1 to W4 on the front-loading chassis with power supplies on the side.

14.2.7 Four-Port HSU*4E 530/35 Card Description (821660)

The four-port HSU*4E 530/35 SS Card is an enhanced version of the 821570 card and supports four EIA530/A or V.35 data ports. The selection EIA530, EIA530A, or V.35 is made on a port-by-port basis using on-board switches.



CAUTION!

If used in a system using a T1 “Line Code” other than “B8ZS,” HSU card ports assigned to multirate circuits greater than or equal to 4 or more consecutive time slots at 64kbps must have DTE connected to the port prior to activation. Failure to attach DTE will cause a false carrier alarm.

14.2.7.1 Features of the Four-Port HSU*4E 530/35 Card (821660)

This enhanced HSU card is a derivative of the 821570 card, with better clock performance and a true V.35 interface. The functionality of the 821660 will be the same as the 821570 except for the addition of a receiver clock invert option.

The 8216xx can be used in any DDS application where the circuit has many timeslots (>24). The enhanced clock jitter provides better tail-circuit performance. Additionally, the transmit and receive clock edges can be individually selected (refer to Tx and Rx CLOCK PLRTY descriptions later in this chapter).

14.2.7.2 Four-Port HSU Card Jumper/Switch Settings

The four-port HSU*4E 530/35 SS Card has a dip switch that must be set for the proper type of interface (either RS-530 or V.35) on ports 1 through 4 of the card. Figure 14-5 shows the dip switch, which are factory-set for RS-530 operation on both ports. To change a port for V.35 operation, reset its associated switch as shown.

Ports can be set individually for either RS530 or V.35 operation, but once set, they remain in that mode until the slide switches are reset.

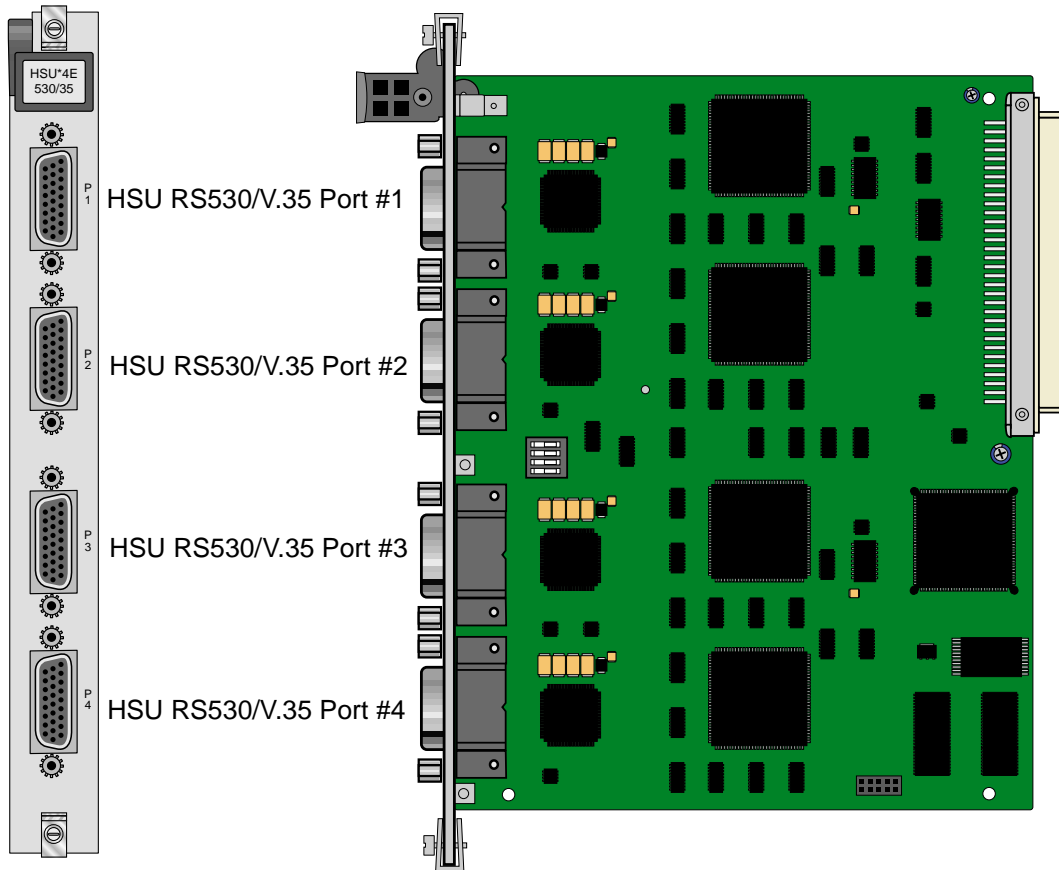

Figure 14-5. Four-Port HSU*4E 530/35 SS Card Switches

14.2.7.3 Installing the Four-Port HSU*4E 530/35 Card

Install the Four-Port HSU*4E 530/35 Card into any user card slots. These slots are U1 to U8 on the two-sided chassis and front-loading chassis with power supplies on top, or P1 to P4 and W1 to W4 on the front-loading chassis with power supplies on the side.

14.2.8 V.35 Personality Module (1251)

When using the two-port HSU 530/35, HSU-AD 530/35, and four-port HSU 530/35 Cards, you may want to connect the RS-530 output jack to RS-232 external equipment (for all of these cards). The V.35 Personality Module is an adapter module that plugs into the female DB-25 port and connectors, then attaches via a male/female connector to the external CPE device. Figure 14-6 shows this module.



Note: *The CPE connection cables should be less than 25 feet long. For RS232 operation, the recommended maximum cable length is less than 25 feet, and the speed should not exceed 56 kbps.*

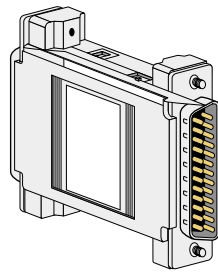

DB25 Male-Female
(Male view)

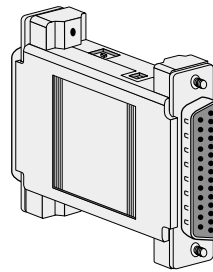

DB25 Male-Female
(Female view)

Figure 14-6.V.35 Personality Module

The three HSU 530/35 Cards also have internal switch settings for changing signals from RS-530 to V.35 format, as previously described. You must also set those switches for RS-530 interfacing when attaching personality modules to the associated card jacks.

14.2.9 RS-232-E Personality Module Description (1253)

The RS-232-E Personality Module converts 530-A signals to RS-232-E format which allows the HSU Cards to interoperate with equipment employing an interface conforming to the ANSI/EIA/TIA-232-E electrical characteristics. Figure 14-7 shows this module.

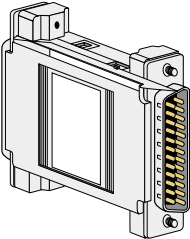

DB25 Male-Female
(Male view)

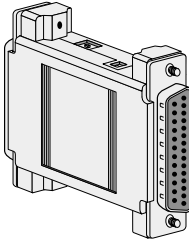

DB25 Male-Female
(Female view)

Figure 14-7.RS-232 Personality Module

14.2.10 HSU Card Cables

Table 14-1 and Table 14-2, represent a matrix used for connecting cables to HSU Cards for DTE and DCE transmit clocking. The following HSU Cards apply (820260, 820360, 821260, 821360, 821460, 821570 and 821660).

Table 14-1. HSU to Cable Matrix (To DTE Clock)

HSU CARD	TO A DTE THAT ACCEPTS CLOCK				
	RS232	RS366	RS449	RS530	V.35
820260 NO SWITCHES	1252/1221*		1212F/M	1204F/M	1203F/1251
820260 WITH SWITCHES	1252/1221*		1212F/M	1204F/M	1261F/M
820360 DCE	1252/1221*		1212F/M	1204F/M	1261F/M
820360 DTE					
821260					1203F/M
821360/821560/821660	1264F/1253**	1206F	1265F/M	1264F/M	1263F/M
821460 DCE					1260F/M
821460 DTE					
821570				1264F/M	
821660				1264F/M	1263F/M
2 PORT EXT. CABLES	1221			1222	1224
4 PORT EXT. CABLES				1269	1268

*820260/820360 Switches set to RS-530 and 1252 Connected to HSU Card

**The 1253 Connects to the end of the 1264F Cable

1253 is a New Version of the 1252 and can replace a 1252.

Table 14-2. HSU to Cable Matrix (To DCE Clock)

HSU CARD	TO A DCE THAT ACCEPTS CLOCK		
	RS449	RS530	V.35
820260 NO SWITCHES	1212X	1204X	1203X/1251
820260 WITH SWITCHES	1212X	1204X	1261X
820360 DCE	1212X	1204X	1261X
820360 DTE			
821260			1203X
821360/821560/821660	1265X	1264X	1263X
821460 DCE			1203X
821460 DTE			
821570		1264X	
821660		1264X	1263X
2 PORT EXT. CABLES		1222	1224
4 PORT EXT. CABLES		1269	1268

14.3 HSU Card User Screens and Settings

The HSU Cards permit configuration and operation through use of several user screens and optional settings.

14.3.1 HSU Card Main Screen

You must configure the HSU Card ports for operation. Configuration can be performed from the HSU Card Main Screen, which is shown in Figure 14-85. To access that screen, highlight the desired card in the System Main Screen and press <Enter>. *The screen displayed in Figure 14-8 shows the 821660 HSU Card.* See the notes in Table 14-4 for other HSU Card settings.



Figure 14-8. Typical HSU Card Main Screen

The bottom highlighted line on this screen lists several actions you can perform from the screen. To perform an operation, simply press the uppercase letter associated with the desired action. For example, to save your option settings, type “s”. Table 14-3 lists the actions you can perform.

Table 14-3. HSU Card Main Screen Actions

Action	Function
Save	Saves changes to settings.
Undo	Returns all settings to the last saved state.
Refresh	Updates certain time-related information fields that are not automatically updated (i.e., performance and test data).
Copy	Copies the contents of the current column to the next column. Useful if you change a lot of entries in one column and want to repeat those changes in subsequent columns.
Test	Initiates and monitors testing of all HSU Card ports. Refer to the Test section of this chapter.
Dial	Allows you to identify the HSU port by telephone number, download and modify call profiles from the Interface card, and dial and broadcast ISDN calls.
Perf	Brings up the Performance Data Screen.
Main	Returns to the System Main Screen. If changes are made to settings and not saved, you will be prompted to save or lose changes.

Table 14-4. HSU Card Setting Options and Defaults

Parameter	User Options	Notes	Default
STATE	stdby actv		stdby
WAN/SRV	wan serv user	1	w1-1
MODE	dce dte	5	dce
TS	table	2	table
RATE	64k 56k		56k
TX CLOCK	int ext		int
Tx CLOCK PLRTY	norm inv	7	norm
DATA PLRTY	norm inv		norm
CTS	perm rlocl ignor local		perm
CTS DELAY	0 30 60 100		0
LOCAL LB	off dte net		off
LB GEN MODE	dds v.54 ft1		dds
LB GEN	off ocu csu (csu-1, csu-2) dsu ds0 (ds0-1, ds0-2)	3	off
LB DET	w/to on off		w/to
ISDN CONN	no	4	no
EER	off on none $10e^{-4}$ - $10e^{-9}$	6	none
Rx CLOCK PLRTY	norm inv	7	norm

Notes:

1. The WAN/SRV parameter has three optional choices: **wan**, **serv** and **user**. In **wan** mode, the options are w1-1 through w4-2. In **serv** mode, the option are P1-P3 and in **user** mode, the options are U1-U8 (Port 1-4).
2. If the WAN selected above has a CSU or DSX module connected, the values range from **1-24**. If a CEPT module is installed the values are **1-31**.

3. These options are only valid if the Loopback Generation Mode selected is **dds**. If the Loopback Generation Mode is **v.54** or **ft1**, then the LB GEN options are **off** and **on**.
4. This is an information-only field, there are no user selections.
5. DTE mode is only for HSU-T (8203, 8214).
6. Displays only for HSU-AD 530/35 (8213).
7. Displays only for HSU*4E 530/35 (8216). For other models the parameter will display CLOCK PLRTY.

STATE

The State setting determines whether the port is active or inactive. An inactive port does not occupy time slots on a WAN link. Set State to standby (**stdby**) for ports you are not using or have not yet configured. Set it to active (**actv**) for ports that are ready for use. The control leads assume the status shown in Table 14-5 for the different states.

Table 14-5. HSU Card State Status

Control Leads	Active	WAN Link Down	Standby
RLSD	High or follows remote RTS	Low	Low
DSR	High	High	Low
CTS	Definable	Definable	High

WAN/SRV

The WAN/SRV setting identifies the card to which the output of this port is directed. If **wan** is chosen, the data from this card port will be directed to a WAN port (the options are **w1-1** to **w4-2**).

If **user** is chosen, the data will be routed to another HSU Card. First, highlight the selected user slot (U1 to U8). Then, if there is a compatible HSU Card in that slot, the system will ask for the number of the port to which you want to connect (1 to 2 or 1 to 4). Type in the number of the port desired. If a number higher than the possible number of available ports is chosen (e.g., 9), the system will automatically select port 1 on the destination user card.



*Note: The **serv** setting is not available for the HSU-T V11 and HSU-T 35 Cards.*

MODE

The Mode parameter appears only for the HSU-T V11 and HSU-T 35 Cards. It allows you to identify how the HSU port appears to the device on the other end of the interface cable. The **dce** option causes the port to be recognized as a DCE (data circuit-terminating equipment) device. The **dte** option causes the port to be recognized as a DTE (data terminal equipment) device.

Note that the choices appearing for some of the parameters that follow will depend on whether you choose **dce** or **dte** as the Mode. Those parameters and their available settings are described below.

TS

The TS (time slot) setting identifies the time slots on the WAN link when **wan** is the WAN/SRV setting. Unlike other user cards, the HSU Card can use many time slots on a single WAN port to create a super-rate circuit for an individual HSU port. One or all DS0 time slots on a single T1 or E1 link can be assembled for use by an HSU port in order to satisfy the speed requirements of the DTE.

The time slot numbers range from **1** to **24** for T1 links and **1** to **31** for E1 links. However, time slot 16 is not available on E1 links programmed for CAS or CCS signaling. Figure 14-9 shows the display when **table** is selected. Using the space bar to select and deselect the time slot, this example shows time slots 11 to 16 on WAN 1-1 assigned to this port. The time slot assignments do not have to be contiguous on any card port.

Note: Do not change this parameter when the HSU Card is linked to an ISDN-PRI connection.



Figure 14-9. Typical HSU Port Time Slot Assignment Screen

RATE

The Rate setting allows you to select the bandwidth for all time slots assigned to this port. The available options are **56k** or **64k**. This selection is multiplied by the number of time slots assigned to the port, to define the overall port speed. For example, if you choose **64k** as the port Rate and assign four time slots to that port, the overall port speed is 256 kbps.

Tx CLOCK

The Transmit Clock (Tx CLOCK) setting identifies the clock source for the SD (send data) signal from the external CPE. The **int** (internal) setting requires an external DTE to synchronize its transmitted data with the clock on the SCT leads. The **ext** (extended) setting requires the DTE to synchronize its transmitted data with the clock on the SCTE leads.

Use **ext** with a long cable run to ensure the data and clock are in-phase when they arrive at the system. The DTE must loop back the clock on the SCT leads to the SCTE leads.

If **ext** is selected but the system does not detect an incoming clock on the SCTE leads, the HSU Card automatically generates an internal clock. If this clock is not synchronized with the incoming data, reset the **CLOCK PLRTY** option to synchronize the clock and data. The Tx **CLOCK PLRTY** option settings are described in the next paragraphs.

On the HSU-T V11, HSU-T 35 and HSU*4E 530/35 SS Cards, the Transmit Clock option can be set only if the Mode for the card port is set to **dce**. The default TX Clock setting in the **dce** mode is **int**. For a **dte** port, the only available setting is **n/a**.

Tx CLOCK PLRTY (821660 card)

The Transmit Clock Polarity (Tx **CLOCK PLRTY**) setting provides another way to compensate for long cables in those cases where the DTE equipment does not provide SCTE. When you choose **inv** (inverted mode), the relationship between the clock and data is altered to compensate for long cable runs that the data signals must traverse between the card port and CPE. When you choose **norm** (normal), the relationship between the clock and data is unchanged. If you use **inv**, set the Tx **CLK** (Transmit Clock) option above to **int** (internal).

On the HSU-T V11, HSU-T 35 and HSU*4E 530/35 SS Cards, the Clock Polarity setting above can be set only if the port Mode is set to **dce**. The default setting in that mode is **norm**. For a **dte** port, the only available setting is **n/a**.

DATA PLRTY

The Data Polarity (**DATA PLRTY**) option allows you to either send all data bits to the network as normal ones and zeros, or to invert all bits in the transmitted data stream. Choose **norm** (normal) to leave the transmitted data intact; or, choose **inv** (inverted) to invert all outgoing data. This can be helpful in ensuring minimum-ones density transmission over T1 links when the data contains long strings of zeros. Inverting the zeros reduces the likelihood that the composite T1 stream will not meet minimum-ones density requirements. Both systems of the end-to-end HSD circuit path require the same **DATA PLRTY** option setting.

On the HSU-T V11 and HSU-T 35 Cards, the Data Polarity option is available only if the port Mode is set to **dce**. The default setting in that mode is **norm**. For a **dte** port, the only available setting is **n/a**.

CTS

The Clear To Send (**CTS**) setting controls when data is sent. Some DTE equipment must receive a CTS signal before transmitting data. Set the CTS option to **perm** (permanent) to make CTS permanently High (asserted). Choose **rlocl** (remote-local) to allow RTS to control both CTS on the local DTE device and RLSD on the remote DTE device.

Choose to **ignor** (ignore) to always force CTS Low (negated). Set the CTS option to **locl** (local) to make CTS follow RTS from the local DTE.

On the HSU-T V11 and HSU-T 35 Cards, the CTS settings are used only if the port Mode is set to **dce**. The default setting in that mode is **perm**. For a **dte** port, the only available setting is **n/a**.

CTS DELAY

The Clear To Send (CTS) Delay setting delays changes in the CTS signal in the local mode. Enter the value you need in milliseconds. The available options are **0**, **30**, **60**, and **100** ms. If you do not know what value you need, start with **0** (zero) ms and increase the value gradually until you no longer experience problems. The CTS option above must be set to **locl** before the CTS DELAY setting has any effect.

On the HSU-T V11 and HSU-T 35 Cards, the CTS Delay settings are used only if the port Mode is set to **dce**. The default setting in that mode is **0** (zero). For a **dte** port, the only available setting is **n/a**.

LOCAL LB

The Local Loopback (LOCAL LB) option activates a loopback on the selected card port. Choose the **dte** setting to loop the outgoing data from the external DTE device back to the DTE receiver. This loopback (see Figure 14-107) allows you to check the local cabling and most of the circuitry in the HSU Card. It also disconnects the incoming data from the far end.

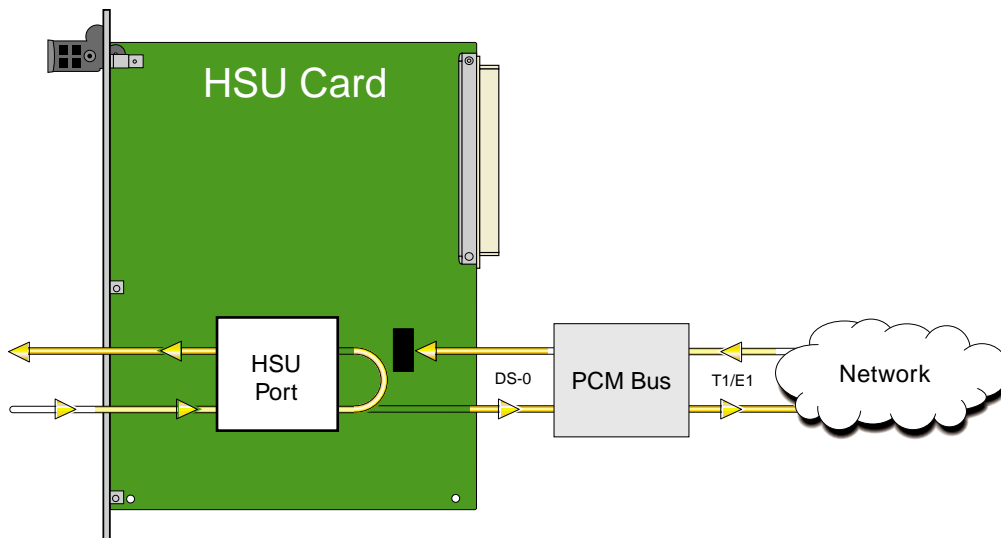

Figure 14-10. Local DTE Loopback

Choose the **net** (network) setting to loop the incoming data from the network back toward the far end. This loopback is shown in Figure 14-1118. It tests some of the local HSU Card circuitry, the local system common cards, the WAN link card, the far-end HSU Card and CPE device, and the WAN link between the two sites. The **net** setting also drops the Data Set Ready (DSR) control signal output on the HSU port.

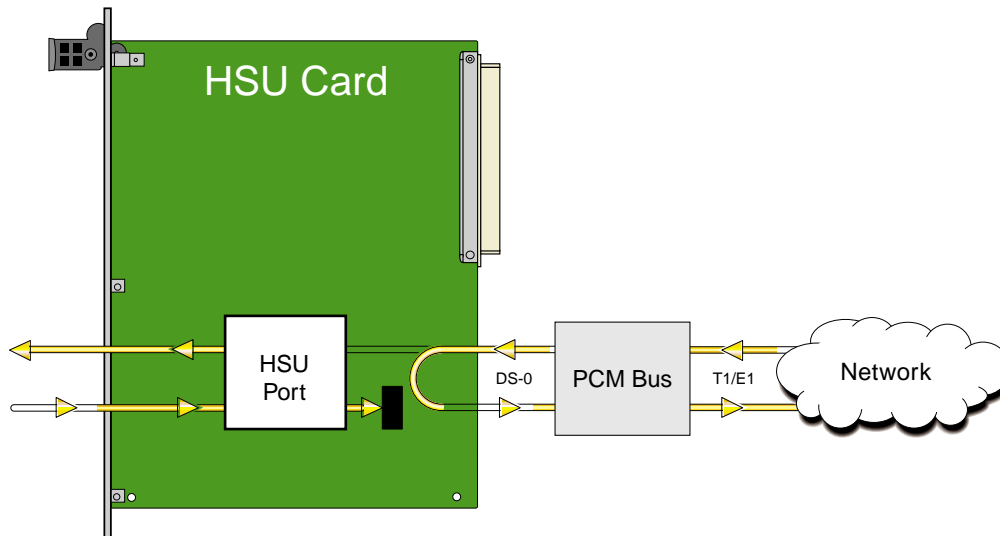

Figure 14-11. Local Network Loopback

On the HSU-T V11 and HSU-T 530/35 Cards, the same choices above appear if the port Mode is set to **dce**. For a **dte** port, the choices are **dce**, **local**, and **off**. The **dce** loopback is functionally identical to the **dte** loopback depicted in Figure 14-107, and the **local** loopback is the same as the **net** loopback depicted in Figure 14-1118.

LB GEN MODE

The Loopback Generation Mode (LB GEN MODE) setting defines the type of inband loop-up and loop-down codes that will be sent to the remote equipment. Three industry-standard codes are supported: **dds**, which sends a DDS-compatible latching loopback code in each of the DS0s that make up the circuit; **v.54**, which is compatible with CCITT V.54 standard and **ft1**, which is compatible with ANSI Fractional T1 standards. The final option, **perf** (performance data), activates an 8 kbps performance data monitoring channel (isolated from the total bandwidth of the circuit) that collects end-to-end performance statistics from a local HSU Card to a remote HSU Card.

On the HSU-T V11 and HSU-T 35 Cards, the same choices above appear if the port mode is set to **dce**. For a **dte** port, this setting is always **n/a**.

LB GEN

If you selected **v.54**, **ft1**, or **perf** as the Loopback Generation (LB GEN) mode setting, the Loopback Generation setting allows you to send an **on** (loop-up command) or **off** (loop-down command). If you selected **dds** as the Loopback Generation mode, this setting allows you to define the type of DDS loopback that you wish to generate. The four options are **ocu** (Office Channel Unit), **dsu** (Data Service Unit), **csu** (Channel Service Unit), and **ds0** (a full 64 kbps loopback). Figure 14-12 through Figure 14-14 show where these loopbacks occur. You can also turn all DDS remote loopbacks **off**.

Note that you cannot perform loop-up and loop-down commands on more than one port of the same card simultaneously. You must finish all loopback operations on one port before starting them on another port.

On the HSU-T V11 and HSU-T 530/35 Cards, the same choices shown above appear if the port Mode is set to **dce**. For a **dte** port, the choices are **llb** (local loopback), **rlb** (remote loopback), and **off**. The **llb** setting loops the incoming signal from the network back toward the network and far end. This loopback occurs at the HSU-T V11 or HSU-T 35 Card. The **rlb** performs the same loopback at the far-end card.

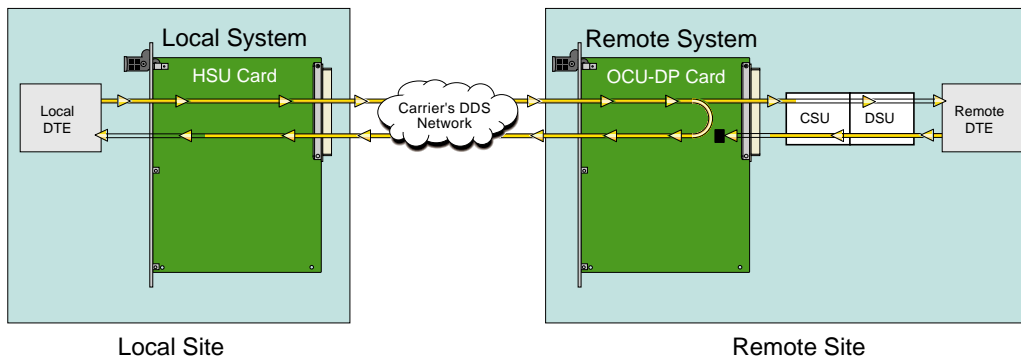

Figure 14-12. Remote OCU or DS0 Loopback

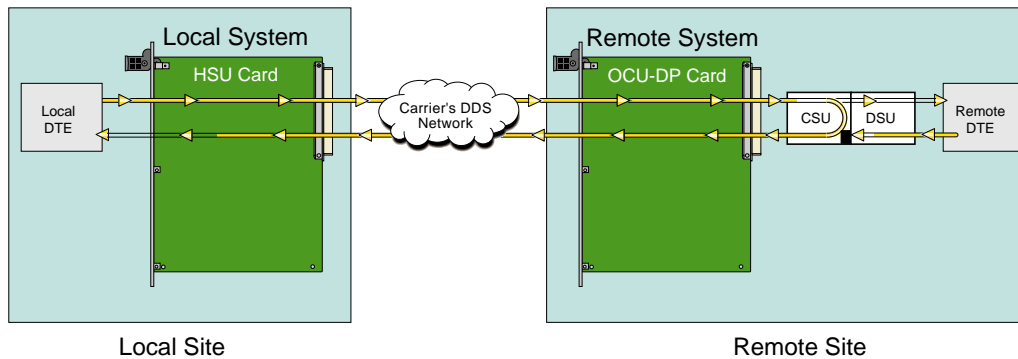

Figure 14-13. Remote CSU Loopback

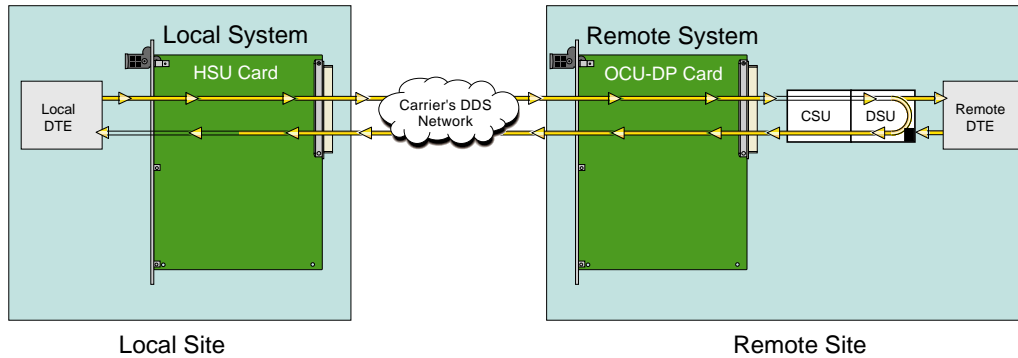

Figure 14-14. Remote DSU Loopback

LB DET

Depending on the selection you made for the Loopback Generation mode above, the HSU Card port will respond to any of the loopback codes generated by a remote system. The Loopback Detection (LB DET) setting lets you enable or disable this capability on each card port. However, this setting does not affect local loopback commands from a local control terminal.

Choose **off** to have the system ignore remote loopback commands. Choose **on** to make the system monitor the card ports for loopback commands sent from the remote equipment. Note that the system will detect only the loopbacks in the format selected as the LB GEN mode. When the system detects a loopback code, it loops the data back until the remote equipment releases the loopback. The **w/to** (with time-out) setting is the same as **on**, except that after 10 minutes the system automatically releases the loopbacks initiated by the remote equipment.

On the HSU-T V11 and HSU-T 35 Cards, the same choices above appear only if the port Mode is set to **dce**. For a **dte** port, this setting is always **n/a**.

ISDN CONN

This option is not available with this host release.

EER (821360 card)

The Excessive Error Rate (EER) parameter is only available on the HSU-AD 530/35 Card. This setting defines an error rate threshold which, when exceeded, causes an alarm to be declared. If the number of errors exceeds this threshold, an **E** will be placed in the Status Column of the card's Performance Monitoring Screen. The available options are from **10e-4** (one error in 10,000 bits) to **10e-9** (one error in 1,000,000,000 bits), or **none**. Choose **none** if you do not want to report alarms for excessive error rates.

Rx CLOCK PLRTY (821660 card)

The Receive Clock Polarity (Rx CLOCK PLRTY) setting provides another way to compensate for long cables in those cases where the DTE equipment does not provide SCTE. When you choose **inv** (inverted mode), the relationship between the clock and data is altered to compensate for long cable runs that the data signals must traverse between the card port and CPE. When you choose **norm** (normal), the relationship between the clock and data is unchanged. If you use **inv**, set the Tx CLK (Transmit Clock) option above to **int** (internal).

Only the HSU*4E 530/35 SS Card supports this parameter. For all other HSU's this setting is **n/a**. The default setting in that node is **norm**. For a **dte** port, the only available setting is **n/a**.

14.3.2 HSU Card Test Screen

Selecting “Test” from the HSU Card Main Screen will access the Test Screen shown in Figure 14-152. From this screen, you can create test situations between HSU Cards, or between a single card and test equipment at a remote site. Table 14-6 lists the actions you can perform from the bottom line of this screen, and Table 14-7 lists the settings presented on this screen, along with their possible and default values.



Figure 14-15. Typical HSU Card Test Screen

Table 14-6. Test Screen Actions

Action	Function
Save	Saves changes to settings.
Undo	Returns all settings to the last saved state.
Refresh	Updates certain time-related information fields that are not automatically updated (i.e., performance and test data).
InsertErr	Allows you to manually insert a single error into the clear data signal.
Clear	Clears the Test Screen and resets all counters to zero.
Main	Returns to the HSU Card Main Screen. If changes are made to settings and not saved, you will be prompted to save or lose changes.

Table 14-7. Test Screen Option Settings and Defaults

Parameter	User Options	Notes	Default
BERT	off mark space 1:1 1:7 511 qrss 2047 ds0 ff 7e 32 40 ocu-a csu-a dsu-a csu1a csu2a	1	off
CTS	norm off on		norm
RLSD	norm off on		norm
DSR	norm off on		norm
SYNC	information only—no user options		
BE	information only—no user options		
ES	information only—no user options		
SES	information only—no user options		
OSS	information only—no user options		
BER	information only—no user options		
ELAP	information only—no user options		
RTS	information only—no user options		
DTR	information only—no user options		
LB ST	information only—no user options		

Notes:

1. The following BERT settings are available only on the four-port HSU 530/35 Card: **ds0**, **ff**, **7e**, **32**, **40**, **ocu-a**, **dsu-a**, **csu1a**, and **csu2a**. These settings are not available on the HSU-T V11 and HSU-T 35 Cards.

BERT

The Bit Error Rate Tester (BERT) sends a data pattern and measures the bit error rate (BER) on the selected HSU port. The patterns that can be selected are **off**, **mark** (1111), **space** (0000), **1:1** (1010 alternating), **1:7** (0100-0000), **511** (511 test pattern), **qrss** (quasi-random signal source), and **2047** (2047 test pattern).

On the four-port HSU 530/35 Card, selecting the **ds0** pattern will display another set of BERT patterns. Additional non-latching loopback patterns are **ff** (1111-1111), **7e** (0111-1110), **32** (0011-0010), **40** (0100-0000), **ocu-a** (ocu-alternating byte), **csu-a** (csu-alternating byte), **dsu-a** (dsu-alternating byte), **csu1a** (csu—one repeater—alternating byte), and **csu2a** (csu—two repeater—alternating byte). The results of the alternating patterns (**ocu-a**, **csu-a**, **dsu-a**, **csu1a** and **csu2a**) appear in the Test Screen.

Also note that the Bit Error Rate Tester is supported on the HSU-T V11 and HSU-T 35 Cards only if the port mode is set to **dce** in their Card Main Screens.

CTS

The Clear To Send (CTS) option allows you to define whether the CTS control lead should be held **on** (high, asserted) or **off** (low, negated). Selecting either **on** or **off** will override the selection made in the HSU Card Main Screen. The third option is **norm** (normal), which allows CTS to operate in the mode selected in the HSU Card Main Screen. *Not available for 820360/821460 when DTE is selected.*

RLSD

The Receive Level Signal Detect (RLSD) option allows you to define whether the RLSD control lead is held **on** (high) or **off** (low). The third option is **norm** (normal), which means that RLSD will behave as described in Table 14-7. *Not available for 820360/821460 when DTE is selected.*

DSR

The Data Set Ready (DSR) option allows you to define whether the DSR control lead should be held **on** (high) or **off** (low). The third option is **norm** (normal), which means that DSR will behave as described in Table 14-7. *Not available for 820360/821460 when DTE is selected.*

SYNC

The Synchronization field indicates if the integrated BERT has achieved synchronization either with itself via a remote loopback or with the remote test equipment. This is an information-only field; it is not user-configurable.

BE

The Bit Error (BE) field indicates the total number of bit errors logged. This is an information-only field; it is not user-configurable.

ES

The Errored Seconds (ES) field indicates the total number of seconds in which errors were detected. This is an information-only field; it is not user-configurable.

SES

The Severely Errored Seconds (SES) field indicates the total number of seconds in which the bit error rate exceeded one bit per thousand (1×10^{-3}). This is an information-only field; it is not user-configurable.

CSES

The Consecutive Severely Errored Seconds (CSES) field is triggered by the occurrence of ten consecutive Severely Errored Seconds. Once triggered, this field will increment (by one) for each elapsed second until the system logs ten consecutive non-Severely Errored Seconds. This is an information-only field; it is not user-configurable.

OSS

The Out of Synchronization Seconds (OSS) field indicates the number of seconds that the HSU BERT has been out of synchronization. This is an information-only field; it is not user-configurable.

BER

The Bit Error Rate (BER) field indicates the rate at which errors are being logged. The system calculates BER by dividing the number of bit errors (BE) by the total number of bits transmitted during the test. This is an information-only field; it is not user-configurable.

ELAP

The Elapsed time (ELAP) setting indicates the running tally of the total number of seconds during the test. This is an information-only field; it is not user-configurable.

RTS

The Request To Send (RTS) field indicates the current status of the RTS control lead. The two values that can be displayed are **on** and **off**. This is an information-only field; it is not user-configurable.

DTR

The Data Terminal Ready (DTR) field indicates the current status of the DTR control lead. The two values that can be displayed are **on** and **off**. This is an information-only field; it is not user-configurable.

The DTR field will always indicate **on** for the HSU 35 Card (Revision A and earlier), but it will toggle between **off** and **on** all other HSU Cards.

LB ST

The Loopback State (LB ST) field indicates whether there are any remotely-initiated loopbacks currently active on the HSU port. This field displays both latching and non-latching loopbacks initiated from a remote device via in-band loop-up codes. In addition to **none**, the six messages that can be displayed in that field are **l-ocu**, **l-dsu** and **l-csu** for latching loopbacks, and **ocu**, **dsu** and **csu** for non-latching loopbacks. This is an information-only field; it is not user-configurable.

14.3.3 HSU Dial Screen

A call profile template must be downloaded to the HSU port before it can be used as a dialing resource by DTE devices, such as video codecs or LAN routers.

Each DTE device is assigned a telephone number which is stored on the HSU port Dial screen. This number will be used as the “Calling Number” on the download copy of a call profile template for outgoing calls. Additionally, this number is used by other DTE as the “Called Number” when placing a call to that device (an incoming call).

Figure 14-16 shows the screen when highlighting the desired HSU port and press “d” (Dial) from the Main Screen of all HSU cards. Table 14-8 lists the screen actions from the bottom of the screen and Table 14-9 lists the available options with the settings and defaults for this screen.



Figure 14-16.HSU Dial Screen

Table 14-8. HSU Dial Screen Actions

Action	Function
Save	Saves changes to settings.
Undo	Returns all settings to the last saved state.
Refresh	Updates certain time-related information fields that are not automatically updated (i.e. performance and test data).
proFile	Brings up the call profile screen.
Load	This option loads a profile from the Interface card template. A call profile number must be inserted. Changes the Current Profile parameter from "none" to "loaded."
Main	Returns to the HSU card main screen. If changes are made to settings and not saved, you will be prompted to save or lose changes.

Table 14-9. Dial Screen Option Settings and Defaults

Parameter	User Options	Default
PRIMARY #	up to 10 numeric characters	0000000000
HUNT GROUP #	up to 10 numeric characters	0000000000
AUTO ANSWER	yes no	yes
ANSWER TIMEOUT	01-60	01
DIAL TRIGGER	off dtr rs366 v.25b	off
ESCAPE CHAR	* # 5 6 7 9 0 00	*
IMUX PRIMARY #	up to 10 numeric characters	0000000000
IMUX HUNT #	up to 10 numeric characters	0000000000
IMUX ADD #	up to 10 numeric characters	0000000000
CURRENT PROFILE	none loaded	none

PRIMARY #

The Primary Number is the main phone number used to route incoming calls for this HSU port. This number must be unique throughout all HSU ports system.

HUNT GROUP #

The Hunt Group Number is an optional number that makes the port of this HSU part of a hunt group. The hunt group number is the same for all HSU ports in the hunt group. The system will route any incoming calls placed to the hunt group number to the first available HSU port in the group. A hunt group number must be within the range of numbers assigned by the carrier controlling the ISDN switch.

AUTO ANSWER

The Auto Answer feature allows the HSU port to automatically answer an incoming call either the primary number or the hunt group number. A value of **yes** means the equipment will always accept the incoming call for an port that is not already busy. A value of **no** means the HSU will not answer the call until the attached DTE responds with DTR high. RS530 ports will respond to auto answer with the Ring Indicator lead, V.35 ports must be set to auto answer for this version of the software.

ANSWER TIMEOUT

If the user chooses **no** for Auto Answer (above), the Answer Timeout parameter tells the system how long to wait for the DTE to raise DTR after the call has been sent to the DTE. This parameter is measured in seconds, and the valid choices are **1-60**.

DIAL TRIGGER

The Dial Trigger tells the 821360 HSU card when to initiate dialing (see Dialing with High Speed Data Cards later in this chapter). *In order for dialing to be initiated, there must be a call profile active for this HSU port.* The values are **n/a** (all other HSU cards), **off** (do not dial any calls), **dtr** (dial the active call profile when the DTE raises DTR), **rs366** (trigger dialing on this port when RS366 commands are received on the associated RS366 port) and **v.25b** (trigger dialing on this port when V.25bis commands are received on the associated V.25bis port).

ESCAPE CHARACTER

The Escape Character is the character used by RS366 dialing as a special character to initiate the dialing command (see next section). The options are: ***, #, 5, 6, 7, 9, 0, 00**.

IMUX PRIMARY

The IMUX Primary Number is the main phone number used to route incoming IMUX calls for this HSU port. This number must be unique throughout all HSU ports in the system. The number must be within the range of numbers assigned by the carrier controlling the IDSN switch.

IMUX HUNT

The IMUX Hunt Number is an optional number that makes the port of this HSU part of a hunt group. The hunt group number is the same for all HSU ports in the hunt group. The system will route any incoming IMUX calls placed to the hunt group number to the first available HSU port in the group, provided there is an available IMUX engine. A hunt group number must be within the range of numbers assigned by the carrier controlling the ISDN switch.

IMUX ADD

The IMUX Add Number is the second number used to synchronize IMUX bandwidth. An IMUX call is placed to the primary number which begins to synchronize the call. Part of that synchronizing process is to report the additional number to the calling IMUX card. The calling IMUX card then dials the IMUX additional number to set up the rest of the bandwidth needed before completing the call. If there is no additional number, the IMUX card will synchronize the call on the primary number only.

CURRENT PROFILE

The Current Profile indicates if a call profile is loaded into the HSU port's dialing memory. The options for this parameter are **none** (indicating that the copy of a call profile template has not been downloaded to this port) or **loaded** (indicating that the copy of a call profile template has been downloaded to this port).

14.3.4 HSU Call Profile Screen

Once a call profile is copied from the Interface card template, it can be used by the DTE on the individual HSU port for placing calls to other devices throughout the network. The HSU Call Profile screen is shown in Figure 14-17. Table 14-10 lists the screen of actions and Table 14-11 lists the settings and defaults for each parameter.

Once the appropriate information is inserted or changed on the fields of this screen, you can place a call by pressing “**D**” (**Dial**) command from the Call Profile screen. When finished, the call can be disconnected by pressing “**H**” (**Hangup**) command from the Call Profile screen.

It is important to note that the HSU port used to dial the call must be in the standby (stdby) state when the call is placed. The state changes from standby to active after the call has been placed. The system will not allow a call to be placed from an active port.



Note: *Any changes made to the loaded call profile will stay with the call profile copy until changed in a future session. Changes made to this copy will not change the call profile template on the Interface card.*



Figure 14-17.HSU Card Call Profile Screen

Table 14-10. HSU Card Call Profile Screen Actions

Action	Function
Save	Saves changes to settings.
Undo	Returns all settings to the last saved state.
Refresh	Updates certain time-related information fields that are not automatically updated (i.e. performance and test data).
Dial	Causes the HSU port to dial the number on the original call profile or the changed call profile.
Bcast	Provides access to the Broadcast screen. See the Broadcast section later in this chapter.
Imux	Provides access to the IMUX screen. See the IMUX section in this chapter.
sTatus	This command shows the status of both ISDN calls and IMUX calls. Press the key once for ISDN call status, press it a second time for IMUX call status.
Hangup	Causes the HSU port to terminate the current call.
Main	Returns to the HSU card main screen. If changes are made to settings and not saved, you will be prompted to save or lose changes.

Table 14-11. HSU Card Call Profile Screen Option Settings and Defaults

Parameter	User Options	Default
DCHAN	01-08	01
CALLED #	telephone number (25 numeric characters)	blank
CALLED # TYPE	natnl intl sbscr	natnl
CALLED # PLAN	unkwn isdn phone print	unkwn
CHANNEL RATE	56u 56r 64u 64r 384u 384r 1536u 1536r MRate	56u
RATE MULTIPLIER	1, 6, 24 2-24 (applies only to MRate)	1
IMUX CALL	no yes	no
SERVICE	service from list set on ISDN card for this D channel (first 7 characters)	blank
CALLING #	telephone number (25 numeric characters)	blank
CALLING # TYPE	natnl intl sbscr	natnl
CALLING # PLAN	unkwn isdn phone print	unkwn
PRESENT. INDCTR	yes no	yes
SCREEN. INDCTR	up-ns	up-ns
BCAST. PHONES	no yes	no

DCHAN

The D Channel number identifies which D Channel to route all outgoing calls that use this call profile. The options are numbers **1-8**.

CALLED #

The Called Number is the full telephone number of the device you are calling. Up to 25 numeric characters are allowed, although most calls use only ten digits. This parameter can be overridden on a call-by-call basis when RS366 or V.25bis dialing is used with the Model 8213 HSU card.

CALLED # TYPE

The Called Number Type identifies the type of network used to reach the called phone number. The options are **natnl** for domestic calls, **intl** for international calls, and **sbscr** for VPN (Virtual Private Network) calls. Your carrier can provide more detail about this option.

CALLED # PLAN

The Called Number Plan refers to the type of numbering plan used to reach the device you are calling. The options are **unkwn**, **isdn**, **phone** and **privt**. Your carrier will provide more detail about this option.

CHANNEL RATE

The Channel Rate selection specifies the bandwidth to be used by the call. Different carriers support different rates, so it is important to check with your carrier before setting rates greater than 64Kbps. When using any Channel Rate other than **MRate**, the system knows the size of the bandwidth required and will automatically select the rate multiplier. If **MRate** is selected, the rate multiplier must be entered by the user.

The **u** (unrestricted) and **r** (restricted) in these selections are for data calls. An unrestricted call means the user can send any type of data information in the circuit. A restricted call means the user is responsible for maintaining the ones-density-integrity of the T1 data stream.



Note: Channel Rates of 1536r and 1536u require the use of NFAS.

If the IMUX CALL field is set to **yes** (see below), the channel rate shows either **56, 64** or **H0** (384K).

RATE MULTIPLIER

The Rate Multiplier parameter is automatically set depending upon the Channel Rate (other than **MRate** or an IMUX call) chosen in the previous paragraph. Valid entries for **MRate** are **2-24**. If an incorrect rate multiplier is input, the carrier equipment will reject the call.

If the IMUX CALL field is set to **yes** (see below), the channel rate shows either **56, 64** or **H0** (384K).

IMUX CALL

The IMUX Call field indicates whether this is an IMUX call or a regular ISDN call. The options are **no** and **yes**. If **yes** is selected, the Channel Rate and Rate Multiplier selections will change (see above).

Since IMUX calls cannot be broadcast, if IMUX call is **yes**, the user will not be able to use the Broadcast Phones option mentioned later in this section.

SERVICE

The Service parameter is entered only if call-by-call service selection is supported on the D channel selected in the DCHAN parameter above. If call-by-call service selection is provisioned on the selected D channel, the first service type is entered in this field automatically. Valid service codes are those that were entered for this D channel in the Services subscreen of the D channel configuration screen.

To change this selection, highlight the selection with the cursor and press the <Enter> key. A list of all service options for this D channel will appear at the bottom of the screen. Move the cursor to the appropriate selection using the right and left arrow keys and press the <Enter> key again when the correct choice is highlighted.

CALLING #

The Calling Number is the phone number of the calling party that is presented to the called party when the incoming call is delivered. (This feature is often known as Automatic Number Identification or “ANI”).

If the user wants the system’s main (billing) number to be presented to the called party, this field must contain a number of up to 25 digits. If the user wants the specific phone number of the HSU port making the call to be presented, this field must be left blank.

CALLING # TYPE

The Calling Number Type identifies the type of network used by the calling party. The options are **natnl** for domestic calls, **intl** for international calls, and **sbscr** for VPN (Virtual Private Network) calls. Your carrier will provide more detail about this option.

CALLING # PLAN

The Calling Number Plan refers to the type of numbering plan used by the calling party. The options are **unkwn**, **isdn**, **phone** and **privt**. Your carrier will provide more detail about this option.

PRESENT. INDCTR

The Present Indicator field determines whether or not the calling number may be displayed to the called party. The selections are **yes** and **no**.

SCREEN. INDCTR

The Screen Indicator field is reserved for future use.

BCAST. PHONES

The Broadcast Phones parameter allows the user to select the use of the Broadcast Option (See the following page). The selections for this parameter are **no** and **yes**.

14.3.5 Broadcast Screen

One of the special features of the HSU Call Profile is the ability to establish a “two-way” connection to the Called # on the Call Profile and broadcast a “one-way” copy of the data sent by the Calling # to a series of additional users. The Bcast Phones parameter must be set to **yes** to enable this feature.

The Broadcast screen allows the user to specify up to eight additional phone numbers of other devices that will receive data from a “host” HSU port in the system. Figure 14-18 shows one of the ways the broadcast feature could work.

In this example, a two-way call is placed from HSU #1 to the primary number, 510-623-1574 (DEV #1). When the call is connected, the system will dial the remaining secondary numbers until all numbers have been dialed and all available connections are established. In this example, it will dial 415-731-6545 (DEV #2), then dial 415-940-7710 (DEV #3). A notation on the screen will signify if the connection is completed.

When the primary call is disconnected, the broadcast connections are also terminated, however secondary callers can disconnect with no disruption of service to the primary or secondary calls.

Selecting no on the Bcast Phones parameter on the Call Profile screen will disable this feature while keeping the list of broadcast phone numbers intact. Figure 14-19 shows the Broadcast screen.

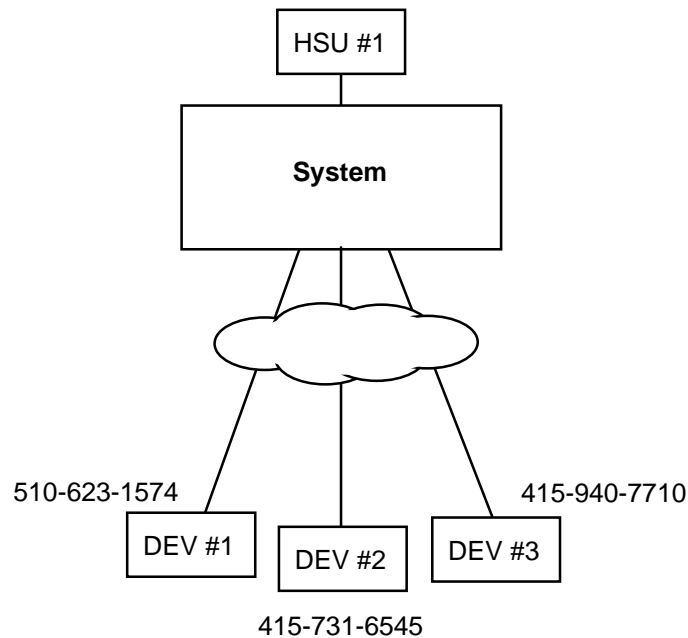

Figure 14-18.HSU Broadcast Function

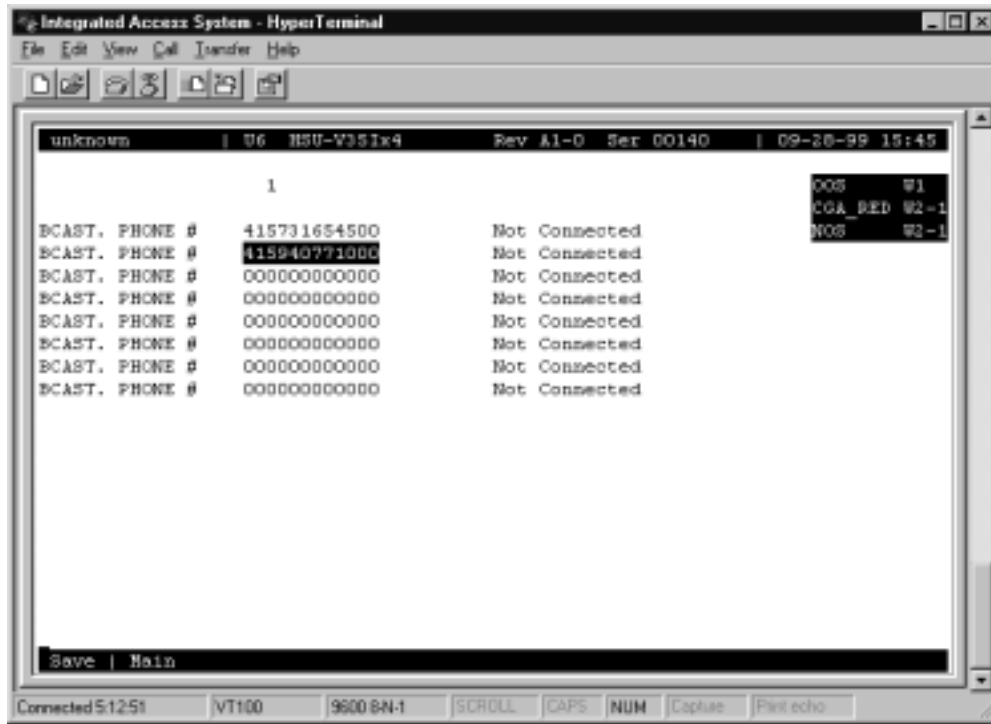

Figure 14-19.HSU Broadcast Screen

14.3.6 Broadcast Connection Status Screen

When the main ISDN call is placed, the system will attempt to establish connection with all of the numbers on the Broadcast screen. The Broadcast screen allows the user to monitor or change the status of each broadcast phone number on the list. Figure 14-20 shows how the example used in the previous section will look after the call is placed. In this example, the call to 415-731-6545 was “Not Connected” while the call to 415-940-7710 was “Connected.”

If the user highlights the “Not Connected” telephone number on the list and uses the “Connect” command, the ISDN card will attempt to place the call again. The status of the call will change to “Connecting.” When the call is completed the status will change to show “Connected.”

To disconnect one of the Broadcast phones prior to the disconnect of the main call, the user highlights the number and uses the “Disconnect” command. The system will prompt you with a yes/no message before action is taken. When disconnected, the call status will change to “Not Connected.”

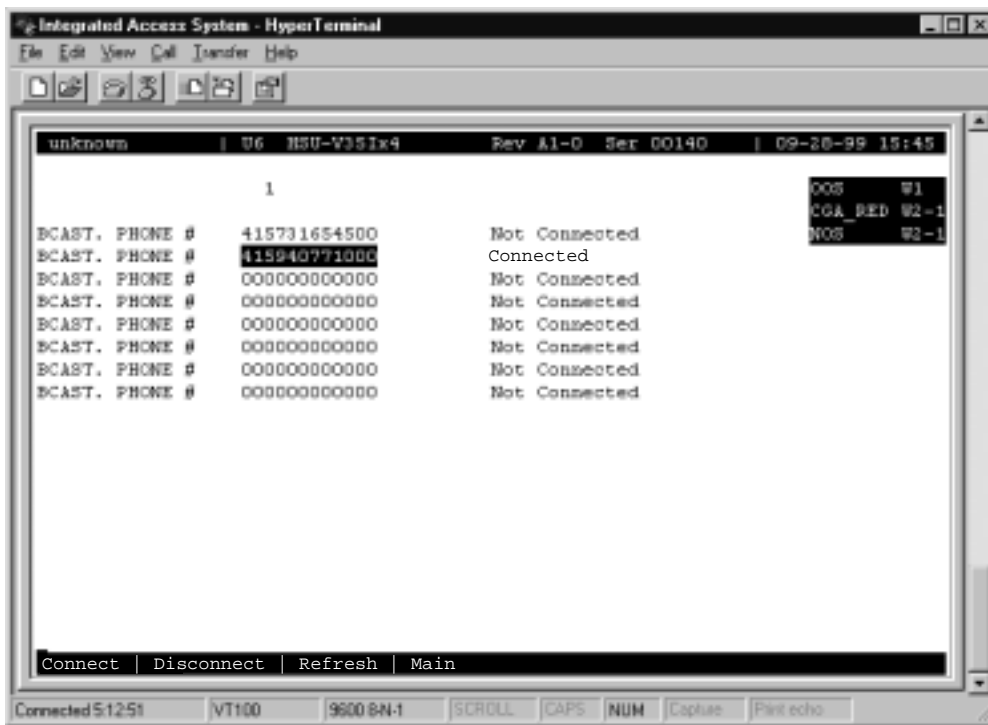

Figure 14-20.Call Profile Broadcast Screen

Table 14-12. Call Profile Broadcast Screen Actions

Action	Function
Connect	If the call placed to one of the Broadcast phone numbers fails to connect, this command will attempt to reconnect the call.
Disconnect	Breaks the connection of the number highlighted on the screen. The user will be prompted with yes/no question before disconnecting.
Refresh	Updates the connection status information.
Main	Returns to the Call Profile screen.

14.3.7 Inverse Multiplexer (IMUX) Screen

The Inverse Multiplexer feature requires the installation of appropriate firmware. An ISDN-PRI card is also required. The screens that follow will only appear when the system is properly configured.

Figure 14-21 displays the IMUX screen. Table 14-13 lists the IMUX screen actions and Table 14-14 shows lists the available options with the settings and defaults.

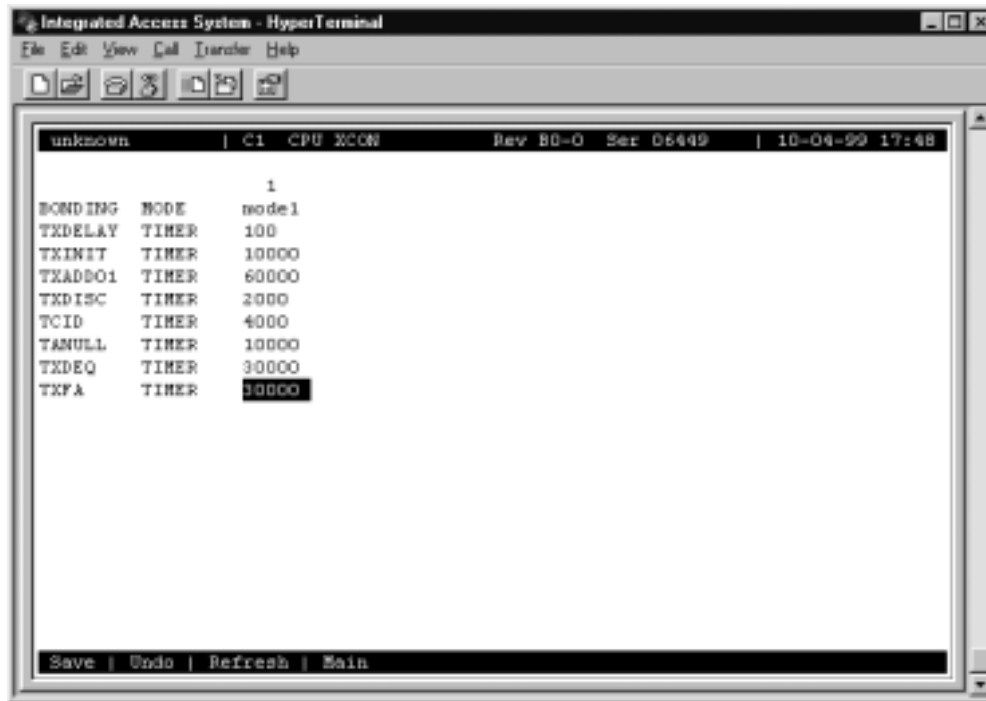

Figure 14-21. IMUX Call Screen

Table 14-13. IMUX Call Screen Actions

Action	Function
Save	Saves changes to settings.
Undo	Returns all settings to the last saved state.
Refresh	Updates certain time-related information fields that are not automatically updated (i.e. performance and test data).
Main	Returns to the HSU call profile screen. If changes are made to settings and not saved, you will be prompted to save or lose changes.

Table 14-14. IMUX Call Screen Option Settings and Defaults

Parameter	User Options	Default
BONDING MODE	mode0 mode1	mode1
TXDELAY TIMER	50 100 250 500	50
TXINIT TIMER	5000 2500 7500 10000	5000
TXADD01 TIMER	60000 40000 80000 120000	60000
TXDISC TIMER	1000 500 1500 2000	1000
TCID TIMER	1000 2000 3000 4000	1000
TANULL TIMER	5000 2500 7500 10000	5000
TXDEQ TIMER	20000 10000 30000 50000	20000
TXFA TIMER	20000 10000 30000 40000	20000

BONDING MODE

The Bonding Mode setting defines which end of the IMUX call will perform the synchronizing tasks needed to complete the call. The options are **mode0** (the end user equipment will synchronize bandwidth) and **mode1** (the terminating IMUX card will synchronize bandwidth).



Note: Almost all IMUX applications will use mode1 synchronization.

TXDELAY TIMER

The Timer (bothway) Delay setting defines the duration of time for the final delay equalization acknowledgment before allowing the call to commence. The values (in milliseconds) are **50**, **100**, **250** and **500**. This timer is used for **mode1** calls.

TXINIT TIMER

The Timer (bothway) Initial Channel setting defines the duration of time necessary for negotiation for the initial 56kbps or H0 (384kbps) channel. The values (in milliseconds) are **5000, 2500, 7500** and **10000**. This timer is used for **mode0** and **mode1** calls.

TXADD01 TIMER

The Timer (bothway) Additional Channel setting defines the duration of time necessary for additional 56kbps, 64kbps or H0 (384kbps) channels to be connected. This value is often called the “call-processing time.” The values (in milliseconds) are **60,000, 40,000, 80,000** and **120,000**. This timer is used for **mode0** and **mode1** calls.

TXDISC TIMER

The Timer (bothway) Disconnect setting defines the duration of time necessary for sending the disconnect indication prior to disconnecting the call. The values (in milliseconds) are **1000, 2000, 3000** and **4000**. This timer is used for **mode1** calls.

TCID TIMER

The Timer Channel Identifier setting defines the duration of time spent by the network looking for secondary B channel allocation information before disconnecting the call. The values (in milliseconds) are **1000, 2000, 3000** and **4000**. This timer is used for **mode2** and **mode3** calls (when available).

TANULL TIMER

The Timer (answer) Null State setting defines the duration of time spent by the called user looking for bonding information before disconnecting the call. The values (in milliseconds) are **5000, 2500, 7500** and **10000**. This timer is used for **mode0** and **mode1** calls.

TXDEQ TIMER

The Timer (bothway) Delay Equalization setting defines the duration of time given the called user to complete equalization of the call. The values (in milliseconds) are **20000, 10000, 30000** and **50000**. This timer is used for **mode1** calls.

TXFA TIMER

The Timer (bothway) Frame Alignment setting defines the duration of time (per channel) for the called user needs to find frame alignment. The values (in milliseconds) are **20000, 10000, 30000** and **40000**. This timer is used for **mode1** calls.

14.3.8 Dialing with High Speed Data Cards

All models of HSU cards can place outgoing calls and can receive incoming calls.

All outgoing calls use call profile information to dial (see HSU Call Profile section earlier in this chapter). A call profile is loaded into an HSU port's dialing memory using the "D" (Dial) option from the HSU Card Screen.

All incoming calls are routed to HSU ports based on the primary and hunt (optional) group phone number(s) assigned to the HSU port. These numbers are assigned to each HSU port using the Dial command option from the HSU Card Screen.

14.3.8.1 Basic HSU Dialing

Any port on any model HSU card can load a call profile into its dialing memory. Once a call profile is loaded, the HSU port can be set to initiate dialing (using the currently loaded call profile information) whenever it senses a raised DTR (Data Terminal Ready) lead from the attached DTE device. Since this DTR lead can have only two values (low-don't dial, and high-go ahead and dial), any call must use the currently-loaded call profile. If the user wants an HSU port to dial a different call profile when DTR goes high, the user must first use the Dial menu to load a different call profile into the HSU port's dialing memory.

14.3.8.2 RS366 and V.25bis HSU Dialing

As described in the previous paragraph, all models of HSU cards can initiate dialing when they sense DTR high, but must use the currently-loaded call profile information to dial.

The HSU 8213 card switched services provides two methods for the DTE to dynamically signal an HSU port to cause it to load a new call profile or to permanently modify the currently-loaded call profile information.

One method uses the RS366 dialing port that is associated with the HSU data port to accept RS366 dialing commands from the DTE. The other method provides dialing commands over the data port using the V.25bis protocol. In both cases, the DTE can command the HSU port to load a call profile into the HSU's dialing memory, then can command the HSU to modify some of the call profile information (e.g. data rate of the call or phone number to dial).

14.3.9 Master Dialing

As described in the previous paragraphs, call profile information can be changed by the DTE prior to making a call only by using RS366 or V.25bis commands. Normally this would limit dynamic DTE dialing to ports on the Model 8213 switched services HSU card. However, there is a way for the DTE to indicate to the system that it wants to do dynamic dialing for an HSU port other than itself.

This type of dialing is called “master” dialing. With master dialing, the DTE will signal the Model 821360 HSU master port (via RS366 or V.25bis) that the following commands should be applied to another HSU port, not to itself. Once the master HSU port receives the command that says “apply all subsequent commands received on this dialing port to a different HSU port,” the master port will process dialing information for another HSU port until it receives a command that says, “apply all subsequent commands to yourself.”

A detailed description of both RS366 and V.25bis dialing command structures are provided on the following pages.

14.3.10 Dialing with RS366 Commands

When the system is equipped with a Model 821360 HSU card, two dialing ports are available for use by that card. Those RS366 ports can also be made available to all HSU cards in the system regardless of the model number using the “Master Dialing” feature.

DTE, such as FAX machines, video codecs and other equipment with dialing capability can send dialing commands to the system using these special dialing ports. The commands are either stores in call profiles or RS366 standard commands using the keypad.

These commands are used to dial a call, call profiles, change the amount of channels required for the session, change service and call types, establish and clear loopback modes and set protocol specific parameters.

The dialing commands are approved by the SDSAF (Switched Digital Services Applications Forum) Subcommittee on DTE-DCE Interfaces (an industry group that has defined extensions to the standard RS366 specifications to support dialing of switched digital services).

Additionally, the system has implemented several extensions to be used specifically with call profile information.

Since the RS366 protocol only allows the transmission of digits, * and #, the command structure must be made up of these characters.

14.3.10.1 Command Types

There are five specific commands available that will override the call profile parameters of the selected HSU port. Each command will be covered as a specific section.

- Basic Change
- Call Profile Loading
- Loopback Management
- Call Profile Change
- Master Dialing

14.3.10.2 Escape Character

The Escape Character marks the beginning of the new command. It can also be used to initiate an action (i.e. dial a phone number).

Values for the Escape Character can be: *, #, 5, 6, 7, 9, 0 (zero) or 00 (double zero). The default value is *.

14.3.11 Basic Dialing Changes

The Basic Dialing Changes involve changes in the channelization of the highlighted HSU port. When using Basic Dialing, the user specifies the number of channels to use, the service type and call type. Optionally, the user can specify a number to dial. **All of the other calling information is derived from the active call profile.**

The Basic Dialing command syntax is: [escape character] [number of channels needed] [service type] [call type] [number of dial (optional)].

A typical command would be: *06300. The first character of the command string is always the escape character (in this case an *).

The second and third characters specify the number of 64kbps channels needed for this call. The options are 00-31. The HSU will appropriate that amount of B channels for the duration of this call. For the above example, 6 channels were chosen for this call.

The third required field is service type (see Table 14-15).

Table 14-15. Values for Service Type Field

Field Value	Meaning
0	Use current value in call profile
1	Switched H11 (1536kbps)
3	Switched H0 (384kbps)
5	Switched 56kbps
6	Switched 64kbps
7	Multirate ISDN

For the above example, service type 3 (Switched H0) was chosen

The fourth required field is call type. The values for this field are 00 (use the current value of call type) and 01 (transparent), a bit-in-bit-out protocol. These are the only call types supported at this time.

14.3.11.1 Example

If a specific call requires a 384kb multirate channel, and the current call profile for that port is set to 64kb channelization can be changed directly from the keypad by typing the digits, *06000. In this case, the escape character tells the HSU that a parameter change is coming, the 06 in the second and third position tells the HSU to change the existing value of 01 (64kb) to 06 (384kb). The 0 in the fourth position means keep the existing service type and 00 in the fifth and sixth places means to keep the existing call type.

There is a special case that applies to basic channelization changes. If the second and third characters of the command string are 00 (zero, zero), it tells the HSU to keep the existing channelization for this port.

The information presented in this section is listed in the RS366 dialing matrix shown in Table 14-18.

14.3.12 Call Profile Loading

Sometimes the user may want to use a different call profile template than the one that is active for a particular HSU port. The change can be performed through either the VT-100 interface or the RS366 port. If the RS366 mode is chosen, the escape character, an eight (8) and three subsequent digits will make up a command string that will designate a new call profile template number to load into the HSU port dialing memory.

The command string for call profile loading is: [escape character] [8] [new call profile number] [number to dial (**optional**)] [escape character to initiate action (**optional**)].

The command, *8002, tells the HSU to replace the currently active call profile (if any) with call profile #002.

Another use of the escape character is to tell the HSU port to initiate dialing. The command, *8002*, tells the equipment to change the active call profile template to call profile template #002, and then dial the called number in that call profile, using all of the parameters in call profile #002.

Other combinations of the elements of the initial RS366 command string can also be useful. The command, *80176231574, tells the HSU to change the call profile to #017 and change the called number to 6231574.

Call profile changes will always have eight (8) in the second position.

The information presented in this section is listed in the RS366 dialing matrix shown in Table 14-18.

14.3.13 Loopback Management

The RS366 command structure allows the user to control the loopback state for active calls within the system. The user can start a call with one RS366 command string and place a loopback on it with another command. Loopbacks can only be initiated on active calls. Table 14-16 shows the loopback commands.

The command string for loopback management is: [escape character] [loopback code].

Table 14-16. Call Profile Parameter Numbers and Values

Loopback Code	Meaning
70	Clear all loopbacks
71	Loopback #1 enable (i.e. DTE loopback)
72	Loopback #2 enable (i.e. local network loopback)
73	Loopback #3 enable (i.e. remote network loopback)

The information presented in this section is listed in the RS366 dialing matrix shown in Table 14-18.



Note: *In order to make use of the loopback management feature, your DTE must support the generate call command while connected and in use.*

14.3.14 Call Profile Changes

Another application for RS366 dialing is modifying call profile parameters that cannot be changed by the Basic Dialing commands. The system uses this application for making changes to all of the fields in the call profiles embedded in the system. A different command string is used to make these changes.

The command string is: [escape character] [64] [parameter number] [parameter value] where the parameters are found on the call profile screen of the Interface card.

Table 14-17 shows the Call Profile parameter name, parameter number and parameter value to be used with this command.

Table 14-17. MUX Call Screen Actions

Parameter Name	Parameter Number	Parameter Value
DChan	01	a number from 01-08
Called #	02	4 through 25 numeric characters can be entered
Called # Type	03	01=natnl, 02=intnl, 03=sbscr
Called # Plan	04	01=unkwn, 02=isdn, 03=phone, 04=print
Channel Rate	05	01=56u, 02=56r, 03=64u, 04=64r, 05=364u, 06=364r, 07=1536r, 09=MRate
Rate Multiplier	06	02-24 (only available if MRate is chosen)
IMUX Call	07	01=no, 02=yes
Service	08	01=first billing plan, 02=second billing plan, etc.
Calling #	09	4 through 25 numeric characters can be entered
Calling # Type	10	01=natnl, 02=intnl, 03=sbscr
Calling # Plan	11	01=unkwn, 02=isdn, 03=phone, 04=print
Present. Indctr	12	01=yes, 02=no
Screen. Indctr	13	01=up-ns

If the IMUX Call is yes, the selection for Channel Rate will be 01=56, 02=64 and 03=H0. If the IMUX Call is used, the selections for Rate Multiplier will be 02-30 for 56/64 and 2-3 for H0.

14.3.14.1 Example

The command, *64122, sets the current value of Present. Indctr to **no**.

The command, *640303, sets the Called Number TYpe to **sbscr**. Call Profile changes permanently alert the active call profile for this HSU port.

The information presented in this section is listed in the RS366 dialing matrix shown in Table 14-18.

14.3.15 Master Dialing

Master Dialing, discussed previously, is another unique application for RS366 dialing for the system when using an 8213 HSU RS366 dialing port to dial for any other HSU card in the system. A different command string is used to make these changes.

The command string is: [escape character] [35] [slot number] [port number], where “slot number” is the user card (1-8) and “port number” is the port in that slot to which subsequent dialing commands should be applied.

The command: *3511, would indicate that the next series of commands would apply to port #1 of the HSU card in slot U1.

Once a Master Dialing command is issued for HSU 821360 RS366 dialing ports, all further dialing commands on this port will be applied to the new slot and port designated by the Master Dialing command.

To return the RS366 to its normal position, the user can apply the special value of 0 (zero). The command, *3500, tells the RS366 dialing to return to its home port. Table 14-18 shows the possible modes of RS366 dialing, and command structures.

Table 14-18. Field Values for Command Strings

Basic Dialing				
Field #1	Field #2	Field #3	Field #4	Field #5
[escape char]	[00-31] Channelization	[service type]	[call type]	[number to dial] Optional
Call Profile Loading				
[escape char]	[8]	[call profile #]	[number to dial] and/or [initiate action] Optional	
Loopback Management				
[escape char]	[70-73]			
Call Profile Change				
[escape char]	[64]	[Parameter #]	[Parameter val]	
Master Dialing				
[escape char]	[35]	[User slot#]	[Hsu port #]	

14.3.16 V.25bis Dialing

The 821360 HSU card also recognizes V.25bis commands, as in-band protocol for dialing by DTE equipment. V.25bis defines two modes, Addressed and Direct. The Direct call mode is enabled by selecting **dtr** as the dial trigger from the Dial Screen on the HSU card. The Addressed call mode is enabled by selecting **v.25b** as the dial trigger. Reference to V.25bis will be for the Addressed mode only. Refers to **dtr** dialing will be for the Direct mode and can be found in the HSU section. This method allows the use of control signals and commands sent over the HSU Card data interface to establish and terminate calls. Addressed calls are packaged in synchronous data frames and are sent when the interface is idle.

CRN commands can alter existing call profiles loaded to the HSU card with new telephone numbers and bandwidth without having to access the call profile through the HSu card screen. CRS commands can load call profiles form the Interface card without having to use the Load command form the HSU card screen.

New call profiles and changes made to existing call profiles are permanent and will remain with the card until changed by any of the procedures discussed in this chapter.

14.3.17 The CRN Command

The Call Request with Number command is sent from the DTE to the HSU card to request a particular number to be dialed. The DTE may include parameters setting the call type, rate bandwidth range, etc.

Other than the new phone number, type and bandwidth, the CRN command uses the data from the currently loaded HSU call profile.

14.3.18 The SCT Parameter

The Switched Call Type parameter to the CRN command selects the type of call made. Call types define the data rate of a single channel, the type of carrier service for the call and indicate if multiple channels can be aggregated for this call. If this parameter is not specified, the value in the HSU Card current call profile is used.

14.3.19 The BWR Parameter

The Bandwidth Request parameter to the CRN command selects the desired bandwidth in terms of the minimum and maximum number of channels the HSU Card can allocate to a call. This parameter is ignored if the SCT does not allow aggregating channels (if N is specified for the SCT parameter). If this parameter is not specified, the value in the HSU Card current call profile is used.

14.3.19.1 Example

An example of a CRN command (using the semicolon character as a field separator) is:
CRN5103537728;SCT56;BWR1-24.

This example commands the system to call the number 510-3537128 using Switched 56kbps and Bandwidth request from 1 to 24 channels.

14.3.20 The CRS Command

The Call Request with Memory Address dials the number and uses all of the parameters on the call profile from those stored on the Interface card. This command changes the current loaded call profile on the HSU card.

14.3.20.1 Example

An example of a CRS command is: CRS4

This example commands the system to change the existing loaded call profile to call profile #4 of the Interface card and dial the number.

14.3.21 The DIC Command

The Disregard Incoming Call command is issued by the DTE to reject an incoming call.

14.3.22 The CIC Command

The Connect Incoming Calling command is issued by the DTE to accept an incoming call. IF the DTE is configured for Auto Answer, the call will be answered if the command is sent or not.

14.3.23 The INC Indication

The Incoming Call indication is sent by the HSU Card to notify the DTE of a pending connection.

14.3.24 The VAL Indication

The Valid Indication is sent to the DTE whenever the HSU Card receives a syntactically valid command (this does not imply it was semantically valid).

14.3.25 The INV Indication

The Invalid Indication is sent to the DTE whenever the HSU Card receives an unknown or syntactically invalid command.

14.3.26 Performance Data

The HSU-AD 5 35 Card supports proprietary end-to-end performance data for super-rate circuits (Nx64 kbps or Nx56 kbps, minus 8 kbps). This mode is only available for users transmitting data from one card (local) to another (remote). You can select between normal operation (full bandwidth allocated to data traffic) and performance data monitoring, where 8 kbps of the total bandwidth is used for monitoring data traffic by selecting the **perf** setting as the Loopback Generation Mode described earlier in the chapter.

Each one-hour reporting period is divided into 3600 seconds, and statistics are kept for the current hour and the past 24 one-hour periods.

Figure 14-22 shows a typical Performance Data Screen, which is accessed by typing “p” (Perf command) from the bottom highlighted line of the HSU Card Main Screen. Table 14-19 lists the actions on the bottom line of the Performance Data Screen.



Figure 14-22. Typical HSU Performance Data Screen

Table 14-19. Performance Data Screen Actions

Action	Function
Refresh	Updates performance data fields that are not automatically updated in real time. Use the Refresh command to display the latest data.
Local	Shows the local register data.
remoTe	Shows the remote register data.
pgUp	Allows you to see the first 12-hour period (current + 1 to 12).
pgDn	Allows you to see the second 12-hour period (current + 12 to 24).
Clearregs	Clears the registers currently being viewed (remote or local).
Main	Returns to the HSU Card Main Screen.

ES

An Errored Second (ES) is any second containing one or more frames of CRC-5 errors.

UAS

An Unavailable Second (UAS) is any second during which service is unavailable. An unavailable signal state is declared after ten consecutive SESs (Severely Errored Seconds) are logged. An unavailable state is cleared after ten consecutive non-Severely Errored Seconds are logged.

SES

A Severely Errored Second (SES) is any second in which the BER exceeds 1×10^{-3} .

BES

A Bursty Errored Second (BES) is any second in which the BER is between zero and 1×10^{-3} .

LOFC

The Loss of Frame Count (LOFC) is the accumulation of the number of times an LOF (Loss Of Frame) is declared. An LOF is declared after 2.5 seconds of a continuous LOS (Loss Of Synchronization) or OOF (Out-Of-Frame) condition. The LOF is cleared after one second without an LOS or OOF condition.

LOPS

A Loss of Packet Second (LOPS) is any second during which no remote data is received. **This is valid only for local statistics.**

STATUS

If one of the errors above occurs during any 15-minute interval, the status column for that period displays the code for that error. The codes are displayed at the bottom of the screen. The possible Status values are **T** (test; port is in loopback), **L** (loss of synchronization, with 2 out of 4 frame bits in error), and **E** (excessive error rate).

14.4 HSU Card Error Messages

Refer to Appendix B in the System Reference Guide for further information on HSU Card Error Messages.

14.5 HSU Card Troubleshooting

Problems with an HSU Card could be caused by a number of things. Typically, a problem is indicated by a loss of incoming signal on a data port at either end of the circuit. You can perform numerous tasks to isolate the trouble and clear it. When troubleshooting transmission problems on a data circuit passing through an HSU Card, follow this general sequence:

1. First, verify that the T1 or E1 network is working properly by checking for current CGA-Red and CGA-Yellow alarms. If the network is faulty, the same transmission problem will exist with the other port of the same HSU Card, and also with the data ports of all other data cards connected to the same T1 or E1 line. If no CGA alarms are present, continue with step 2.
2. If the trouble exists on both ports of the same card, but not on any other cards, replace the local HSU Card. If the trouble is only with the current HSU Card and port, continue with step 3.
3. Check the DS0 time slot assignments of the faulty port at both ends of the data circuit path. Also be sure the port is connected to the proper WAN card and port at each end. If these assignments are correct, continue with step 4.
4. At the local end (where the incoming data loss was first observed), use the loopback and test signal functions of the HSU Card to test the affected port. These tests are accessible from the HSU Card Main Screen and associated Test Screen, as previously described in this chapter. They allow you to test the circuit path in segments and thereby quickly pinpoint the problem.
5. If necessary, also perform loopbacks and send test signals to the affected circuit from the other end. In addition, you can perform end-to-end tests using a suitable data test set at one or both ends of the circuit in conjunction with the loopback functions of the HSU Card at either end.
6. If the HSU Card is determined to be faulty, replace it and return the faulty unit for repair to the location specified by your distributor.

14.6 HSU Card Specifications

Model Number	Number of Data Ports	Physical Interfaces	Electrical Interfaces
820260	2	2 female 25-pin DB25 D-connectors	ITU-T V.35, V.11, RS232, RS530/RS449, V.24*
820360	2	2 female 25-pin DB25 D-connectors	ITU-T V.11, RS 530
821260	2	2 female 25-pin DB25 D-connectors	ITU-T V.35 (True V.35)
821360	2	2 female 26-pin DB26 D-connectors	ITU-T V.35, V.11, RS232, RS530, V.24* (V25 bis and/or RS-366 dialing when used with 8840 PRI Card)
821460	2	2 female 26-pin DB26 D-connectors	ITU-T V.35 (True V.35)
821560	4	4 female 26-pin DB26 D-connectors	ITU-T V.35, V.11, RS232, RS530, V.24*



Note: *External adapter is required.

Data Speeds	N x 56k and N x 64k, where N = 1 to 31 (up to 1984 kbps) - Software Configurable by DS0
Data Format	Synchronous
Data Protocol	Transparent
Transmit Clock per Port	Internal or External (software selectable)
Clock Polarity per Port	Normal or inverted (software selectable)
Data Polarity per Port	Normal or inverted (software selectable)
Dial Capability	Model 821360 only (when used with 8840 PRI Server Card)
Number of Dialing Ports	2
Dialing Electrical Interface	EIA RS-366, ITU-T V.25 bis
Dialing Physical Interface	2 female 15-pin D-connectors
ISDN Call Profiles - Software	
Primary Number	Main phone number used to route incoming calls for this HSU port
Hunt Group Number	Optional number that makes the port of this HSU part of a hunt group
Auto Answer	Allows the HSU port to automatically answer an incoming call for the primary number or the hunt group number
Answer Time Out	How long to wait for the DTE to raise DTR after the call has been sent to the DTE
Escape Character	To initiate the dialing command
IMUX Primary Number	The main phone number used to route incoming IMUX calls for this HSU port
IMUX Hunt Number	An optional number that makes the port of this HSU part of a hunt group
IMUX Add Number	Second number used to synchronize IMUX bandwidth
Channel	D-channel on which to route all outgoing calls that use this call profile
Called Number	Full telephone number of the device you are calling
Channel Rate	Bandwidth to be used by the call
IMUX Call	Whether this is an IMUX call or a regular ISDN call
Service	Service from list set on ISDN card for this D channel (first 7 characters)
Calling Number	Automatic Number Identification (ANI)
Present Indicator	Determines whether or not the calling number may be displayed to the called party
Broadcast Phones	Select the use of the Broadcast option
Diagnostics	V.54 or DDS format local and remote loopbacks with automatic timeout
RTS/CTS Delay: per Port	0, 30, 60 or 100 ms (software selectable by port)
RTS Handshake per Port	Permanent, local, ignore, local (software selectable by port)
BER Test per Port	Active or inactive BER Test Patterns All Marks, All Spaces, 1:1, 1:7, QRSS, 511, 2047 On the four-port HSU 530/35 Card, there are additional BERT patterns
Local Loopback per Port	None, towards DTE, towards the network
Loopback Generation per Port	Off, CSU, DSU, OCU-DP, V5.4, DS0
Loopback Detection per Port	Disabled, enabled, enabled with timeout
Performance Statistics	Errored Seconds, Unavailable Second, Severely Errored Second, Burst Errored Second, Loss of Packet Seconds, Loss of Frame Count

Standards Compatibility

ITU-T	V.35	Data Transmission of 48 kbps using 60-108 kHz Group Bank Circuits.
	V.11 (10/96)	Electrical characteristics for balanced double-current interchange circuits operating at data signaling rates up to 10 Mbit/s.
	V.28	Electrical characteristics for unbalanced double-current interchange circuits.
	V.25 bis	(Model 821360 only) (10/96) - Automatic answering equipment and general procedures for automatic calling equipment on the general switched telephone network including procedures for disabling of echo control devices for both manually and automatically.
EIA	Recommendations RS-422	Electrical Characteristics of Balanced Voltage Digital Interface Circuits.
	Recommendations RS-449	General Purpose 37 Position and 9 Position Interface for DTE and DCE Equipment Employing Serial Binary Data Interchanges.
	Recommendations RS-530	High Speed 25 Position Interface for Data Terminal Equipment, Including Alternative 25 Position Connector.
	Recommendations RS-366	Interface between Data Terminal Equipment and Automatic Calling Equipment for Data Communication.
UL	1950	UL Standard for Safety of Information Technology Equipment.
CEN	EN 50 082-1	Electromagnetic compatibility generic emission standard Part 1 Residential, commercial and light industry.
	EN 50 082-2	Electromagnetic compatibility generic immunity standard Part 1 Residential, commercial and light industry.
	EN 60 950/A2	Safety of information technology equipment including electrical business equipment.

Chapter 15

OHSU Cards

15.1 Introduction

This chapter provides installation, configuration, and troubleshooting information for the Optical High-Speed Data Unit (OHSU) cards. IMACS host code release 7.2.0 introduces the 4-port Optical HSU card. The cards are labeled on the faceplate ejector as either the two-port OHSU (8237) card, or the 4-port OHSU (8238) card. The OHSU cards allows the customer to connect to Tele Protection Equipment (TPE) in compliance with IEEE C37.94.

15.2 OHSU Card Description

15.2.1 Four-Port OHSU Card Description (823870, 823875)

The OHSU card provides four full duplex IEEE C37.94 optical ports for optical serial N times 64 kbps interface capability. Each optical port contains a transmit (Tx) and receive (Rx) connector along with a status LED. There are two versions of the card, both make use of multi-mode fiber cables. The 823870 uses 830nm fiber, and the 823875 uses 1310nm fiber.

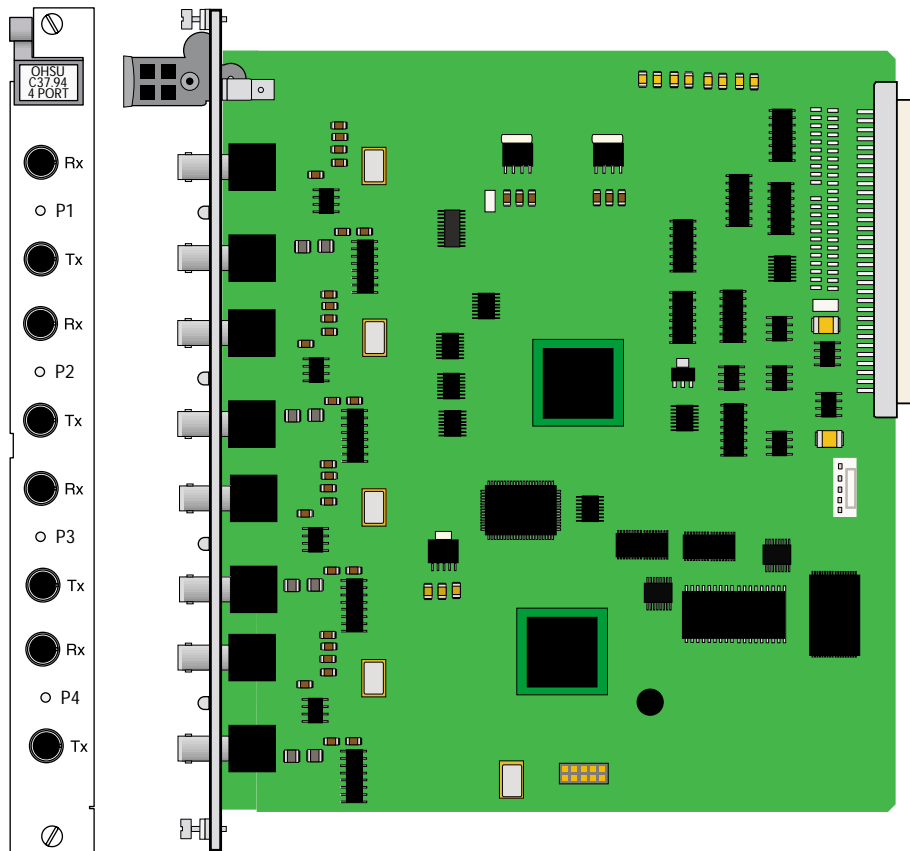

Figure 15-1.4-Port OHSU Card

15.2.1.1 Installing the Four-Port OHSU Card

Install the Four-Port OHSU Card into any user card slot. These slots are U1 to U8 on the two-sided chassis and front-loading chassis with power supplies on top, or P1 to P4 and W1 to W4 on the front-loading chassis with power supplies on the side.

15.2.2 Two-Port OHSU Card Description (823760)

The OHSU card provides two full duplex IEEE C37.94 optical ports for optical serial N times 64 kbps interface capability. Each optical port contains a transmit (Tx) and receive (Rx) connector along with a status LED.

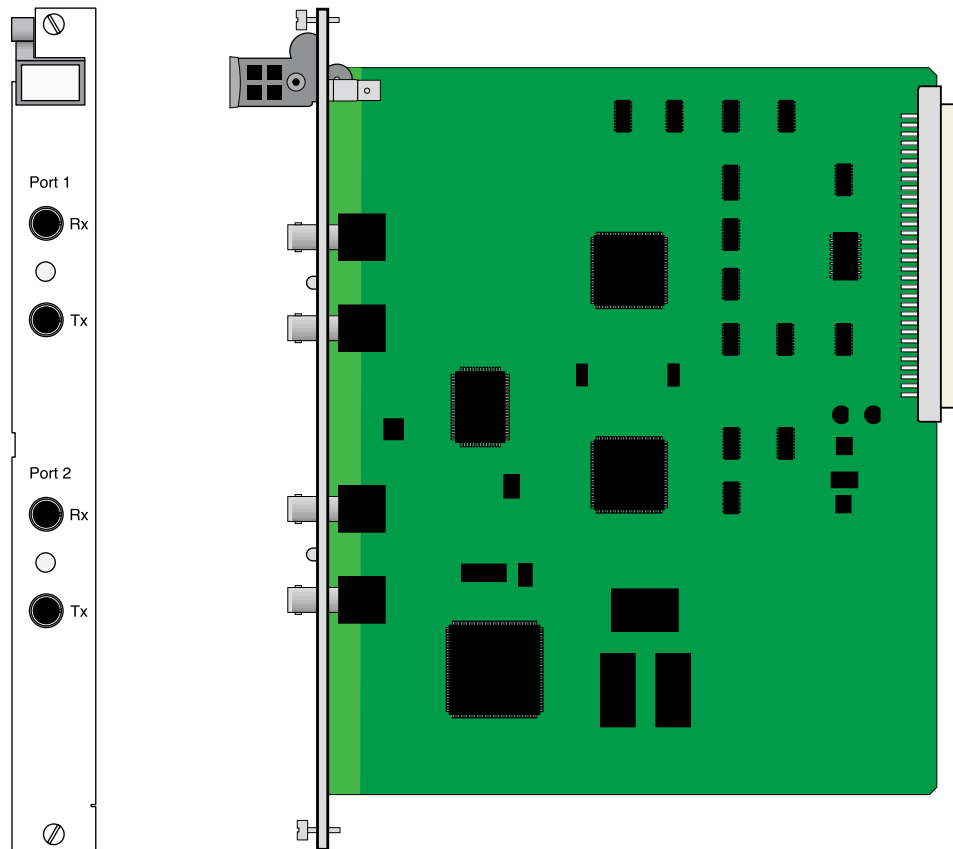

Figure 15-2. Two-Port OHSU Card

15.2.2.1 Installing the Two-Port OHSU Card

Install the Two-Port OHSU Card into any user card slot. These slots are U1 to U8 on the two-sided chassis and front-loading chassis with power supplies on top, or P1 to P4 and W1 to W4 on the front-loading chassis with power supplies on the side.

15.2.3 OHSU card cables

The OHSU card utilizes duplex 50 um or 62.5 um optical fiber cables with BFOC12.5 (ST) connectors. A separate transmit and receive fiber is required for each port.

15.3 OHSU Card User Screens and Settings

The OHSU Cards permit configuration and operation through use of several user screens and optional settings.

15.3.1 OHSU Card Main Screen

You must configure the OHSU Card ports for operation. Configuration can be performed from the OHSU Card Main Screen, which is shown in Figure 15-3. For the four-port card, four ports are displayed instead of two. To access that screen, highlight the desired card in the System Main Screen and press <Enter>.



Figure 15-3. Typical OHSU Card Main Screen

The bottom highlighted line on this screen lists several actions you can perform from the screen. To perform an operation, simply press the uppercase letter associated with the desired action. For example, to save your option settings, type “s”. Table 15-1 lists the actions you can perform.

Table 15-1. OHSU Card Main Screen Actions

Action	Function
Save	Saves changes to settings.
Undo	Returns all settings to the last saved state.
Refresh	Updates certain time-related information fields that are not automatically updated (i.e., performance and test data).
Copy	Copies the contents of the current column to the next column. Useful if you change a lot of entries in one column and want to repeat those changes in subsequent columns.
Test	Initiates and monitors testing of all OHSU Card ports. Refer to the Test section of this chapter.
Perf	Brings up the Performance Data Screen.
Main	Returns to the System Main Screen. If changes are made to settings and not saved, you will be prompted to save or lose changes.

Table 15-2. OHSU Card Setting Options and Defaults

Parameter	User Options	Default
STATE	stdby actv	stdby
WAN/SRV	wan (W1-1...W4-2) serv (P1-P3) hsu (U1-U8)	none
MODE	mux	mux
TS	table (up to 12 TS)	no assignment
RATE	64k	64k
TX CLOCK	int (mux MODE)	int
LOCAL LB	off user net	off

STATE

The State setting determines whether the port is active or inactive. An inactive port does not occupy time slots on a WAN link. Set State to standby (**stdby**) for ports you are not using or have not yet configured. Set it to active (**actv**) for ports that are ready for use.

WAN/SRV

The WAN/SRV setting identifies the card to which the output of this port is directed. Only **wan** can be chosen, the data from this card port will be directed to a WAN port (the options are **w1-1** to **w4-2**).

MODE

The Mode parameter appears for information only. The OHSU is fixed in the MUX mode.

WAN TS

The TS (time slot) setting identifies the time slots on the WAN link. Unlike other user cards, the OHSU Card can use many time slots on a single WAN port to create a super-rate circuit for an individual OHSU port. One to 12 DS0 time slots on a single T1 or E1 link can be assembled for use by an OHSU port in order to satisfy the speed requirements of the Tele Protection Device (TPD).

The time slot numbers range from **1** to **24** for T1 links and **1** to **31** for E1 links. However, time slot 16 is not available on E1 links programmed for CAS or CCS signaling. Figure 15-4 shows the display when **table** is selected. Using the space bar to select and deselect the time slot, this example shows time slots 1 to 5 on WAN 1-1 assigned to port 2. The time slot assignments have to be contiguous on any card port.



Figure 15-4. Typical OHSU Port Time Slot Assignment Screen

RATE

As defined in IEEE C37.94, the data rate per timeslot is only 64 kbps. This field cannot be changed.

Tx CLOCK

The OHSU ports behave as IEEE C37.94 MUX ports so the Transmit Clock (Tx CLOCK) setting can only be **int** (internal).

LOCAL LB

The LOCAL Loopback (LOCAL LB) option activates a loopback on the selected card port. Choose the **User** setting to loop the outgoing data from the external TPE device back to the TPE receiver. This loopback (see Figure 15-57) allows you to check the local cabling and most of the optical circuitry in the OHSU Card. It also disconnects the incoming data from the far end.

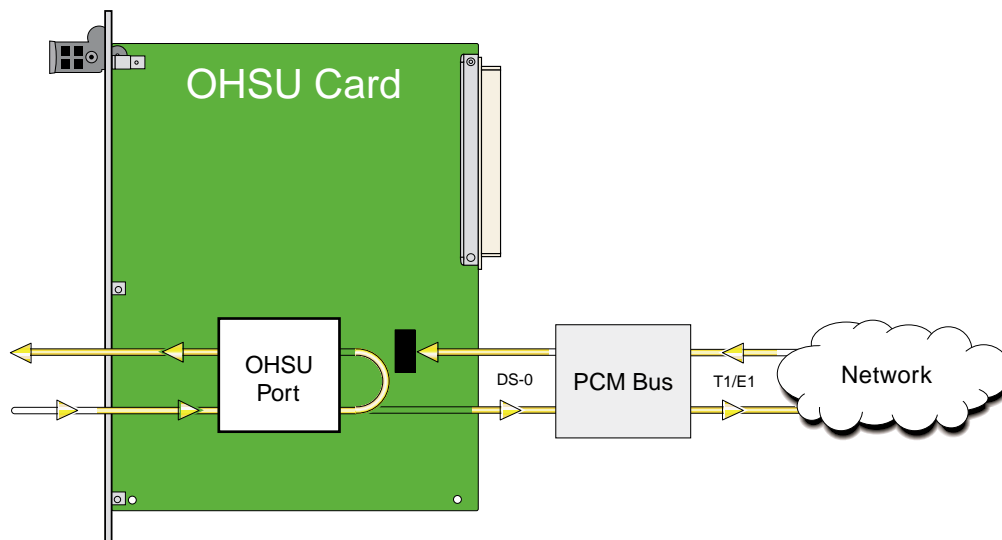

Figure 15-5. Local User Loopback

Choose the **net** (network) setting to loop the incoming data from the network back toward the far end. This loopback is shown in Figure 15-618. It tests some of the local OHSU Card circuitry, the local system common cards, the WAN link card, the far-end OHSU Card and CPE device, and the WAN link between the two sites.

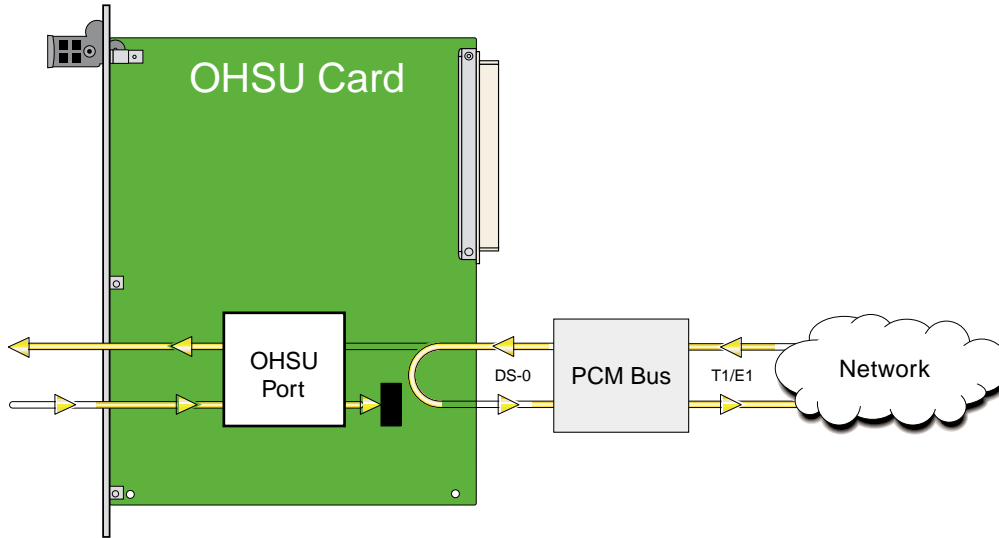

Figure 15-6. Local Network Loopback

Alarm

The alarm field is an indication field that shows the optical link status.

Table 15-3. Alarm Field

Field	Optical Link Status
Norm	The optical link is operating properly.
Yel	The TPE is reporting a reception fault.
Red	The OHSU card is reporting a reception fault.

15.4 OHSU Card Specification

Model Number	Number of Data Ports	Physical Interfaces	Optical Interfaces
823760	2	4 ST connectors	IEEE C37.94
823870 823875	4	8 ST connectors	IEEE C37.94

Data Speeds N x 64k, where N = 1 to 12 - Software Configurable
Data Format Synchronous
Data Protocol Transparent
Transmit Clock per Port Internal

Standards Compatibility

IEEE C37.94

Optical Requirements

Optical fiber core size: 50um; 62.5um
 Operational distance: up to 2km.
 Optical fiber connector: BFOC/2.5 (ST)
 Optical wavelength: 830 +/- 40nm
 Optical output signal level: < -11.0 dBm, > -23.0 dBm (50um fiber) or > -19.0 dBm (62.5um fiber)
 Optical input sensitivity: < -11.0 dBm, > -32.0 dBm
 Optical data sense: light 'ON' for logic '1' bits

Clock Requirements

Optical signal data rate: 2048 kbps
 Normal XMT clock source: from IMACS system source.
 Normal RCV clock source: from external equipment synchronized to the IMACS system source.
 At fault RCV clock source: from external equipment's internal source.
 Jitter: from IMACS system, +/- 50 nS. IMACS will tolerate +/- 100 nS.
 Wander: IMACS will tolerate round trip wander of +/- 250 nS.

The 823760 and 823870 utilize 820 nM multi-mode optical cables

The 823875 utilizes a 1310 nM multi-mode optical cable.

Chapter 16

SRU Card

16.1 Introduction

This chapter provides installation, configuration, and troubleshooting information for the Subrate Data (SRU) Card, which is identified as an SRU 232*10 (822060), SRU 232*10 C&D Bus (8221), SRU-422*4 (8224) and the SRU-LD*10 (8225) card on its faceplate ejector.

The SRU 232*10 Card allows you to connect up to 10 RS-232, low-speed and medium-speed (300 kbps to 38.4 kbps) data terminals to the Integrated Access System. You can multiplex a number of those devices onto a single DS0 time slot of a WAN card. The card ports can also be multiplexed with voice traffic on an ADPCM engine.

Each port of the SRU 232*10 Card receives timing from either the external DTE or the Integrated Access System clock. If the DTE supplies the transmit timing, that clock signal must be synchronized to the Integrated Access System's clock source.

The SRU-LD*10 Card allows you to connect up to ten (10) RS-232, low-speed and medium-speed data terminal to the Integrated Access System. The functionality of the SRU-LD*10 card is the same as the SRU 232*10 card with the exception of a lower delay throughput.

Note: Some new changes to SRU Cards require that the cards be put in standby then the active modes for the changes to take effect.

16.2 SRU Card Descriptions

16.2.1 SRU 232*10 Card Description (822060)

The SRU 232*10 Card supports published Digital Data Service (DDS) rates. Typical DDS rates include 2.4, 4.8, 9.6, and 19.2 kbps. Up to ten 4.8 kbps DTE devices can be connected to this card for placement on a single DS0 time slot of a T1 or E1 line. Or, the card can similarly accommodate up to five 9.6 kbps devices.

You can also mix rates on the individual ports of an SRU 232*10 Card. Any combination of rates can be used, up to an aggregate total bandwidth of 115 kbps for the card. For example, you can connect three 9.6 kbps terminals and one 19.2 kbps terminal to a single card. Other DTE transmission rates supported by the card include 300 bps, 14.4 kbps, 28.8 kbps, and 38.4 kbps.

16.2.1.1 Card Jumper/Switch Settings

The SRU 232*10 Card has US/Euro jumpers or switches on its mainboard. JP1 and JP2. See Figure 16-1.

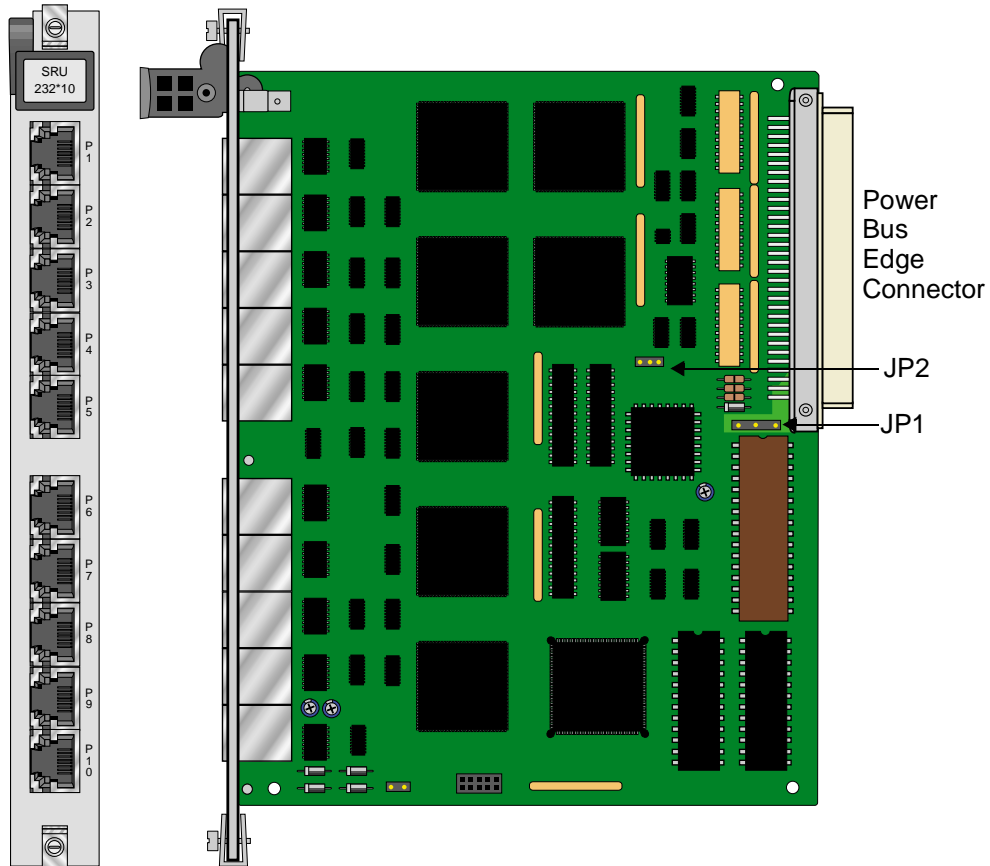

Figure 16-1.SRU 232*10 Jumper Settings

16.2.1.2 Installing the SRU 232*10 Card

Install the SRU 232*10 Card into any user card slot. These slots are U1 to U8 on the two-sided chassis and front-loading chassis with power supplies on top, or P1 to P4 and W1 to W4 on the front-loading chassis with power supplies on the side.

16.2.2 SRU 232*10 C&D Bus Card Description (822160)

The SRU 232*10 C&D Bus Card is functionally equivalent as the SRU 232*10 (822060) card. When used with the SRU 232*10 (822060) card it increases the SRU port density per Integrated Access System beyond the current limit of 60.

16.2.2.1 Card Jumper/Switch Settings

The SRU 232*10 C&D Bus Card has US/Euro jumpers or switches on its mainboard. JP1 and JP2. See Figure 16-2.

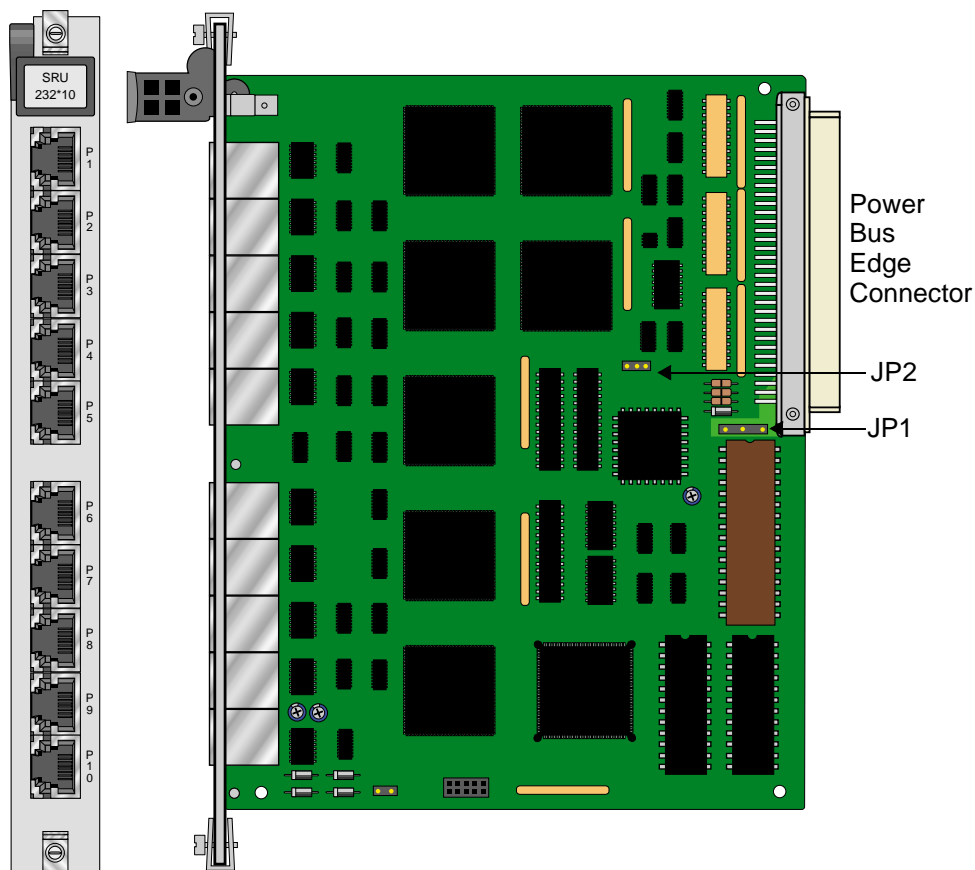

Figure 16-2. SRU 232*10 C&D Bus Jumper Settings

16.2.2.2 Installing the SRU 232*10 C&D Bus Card

Install the SRU 232*10 C&D Bus Card into any user card slot. These slots are U1 to U8 on the two-sided chassis and front-loading chassis with power supplies on top, or P1 to P4 and W1 to W4 on the front-loading chassis with power supplies on the side.

16.2.3 LD-SRU*10 Card Description (822570)

The LD-SRU*10 Card allows you to connect up to ten (10) RS-232, low-speed and medium-speed data terminal to the Integrated Access System. The functionality of the LD-SRU*10 card is the same as the SRU 232*10 card with the exception of a lower delay throughput. The maximum of 3 ms +/- 10% end to end of rates 9.6 kbps or higher for sync and the maximum of 6 ms +/- 10% end to end of rates 9.6 kbps or higher for async.

Please refer to release notes 830-03855-xx for the latest information on functions and restrictions for the PRM-822570 LD-SRU card. At this time, ADPCM, HLINK and b-10 and b-20 modes are not supported. Also b-5 can be used, but must be assigned to ports 1-5 and 6-10.

There are several methods to determine if the card in use is a 822570 as opposed to the 822560:

1. Ejector label. The PRM-822570 card indicates it is an LD-SRU card. The PRM-822560 card indicates and SRU-LD, and the third line of the ejector label indicates "SS". The third line of the PRM-822570 card is blank.
2. Faceplate numbering. The PRM-822570 card has ports labeled 1 through 10, where the last number (10) has the digits side by side. The PRM-822560 card has port labeled P1 through P10, and the letters and numbers are all arranged vertically.
3. Load installed. Logging into the IMACS shelf, the user can see the load installed on either the 'P' for programming screen, or on the card provisioning ports display. This latter method is not service affecting. The PRM-822570 card has a load beginning with the number '2', as in 2.0.1. The PRM-822560 card has a load starting with the number '1', as in 1.0.1.
4. Faceplate fasteners. The PRM-822570 card has thumbscrews for fasteners, which are larger and can be turned with a phillips or straight-edge screwdriver. The PRM-822560 has smaller screws that can be turned only with a straight-edge screwdriver, and the faceplate itself has raised "dimples" where the screw is located. The PRM-822570 has no such "dimple". See Figure 16-3 and Figure 16-4 for representations to the two cards.

16.2.3.1 Card Jumper/Switch Settings

The 822570 LD-SRU*10 Card has no jumpers or switches on its mainboard.

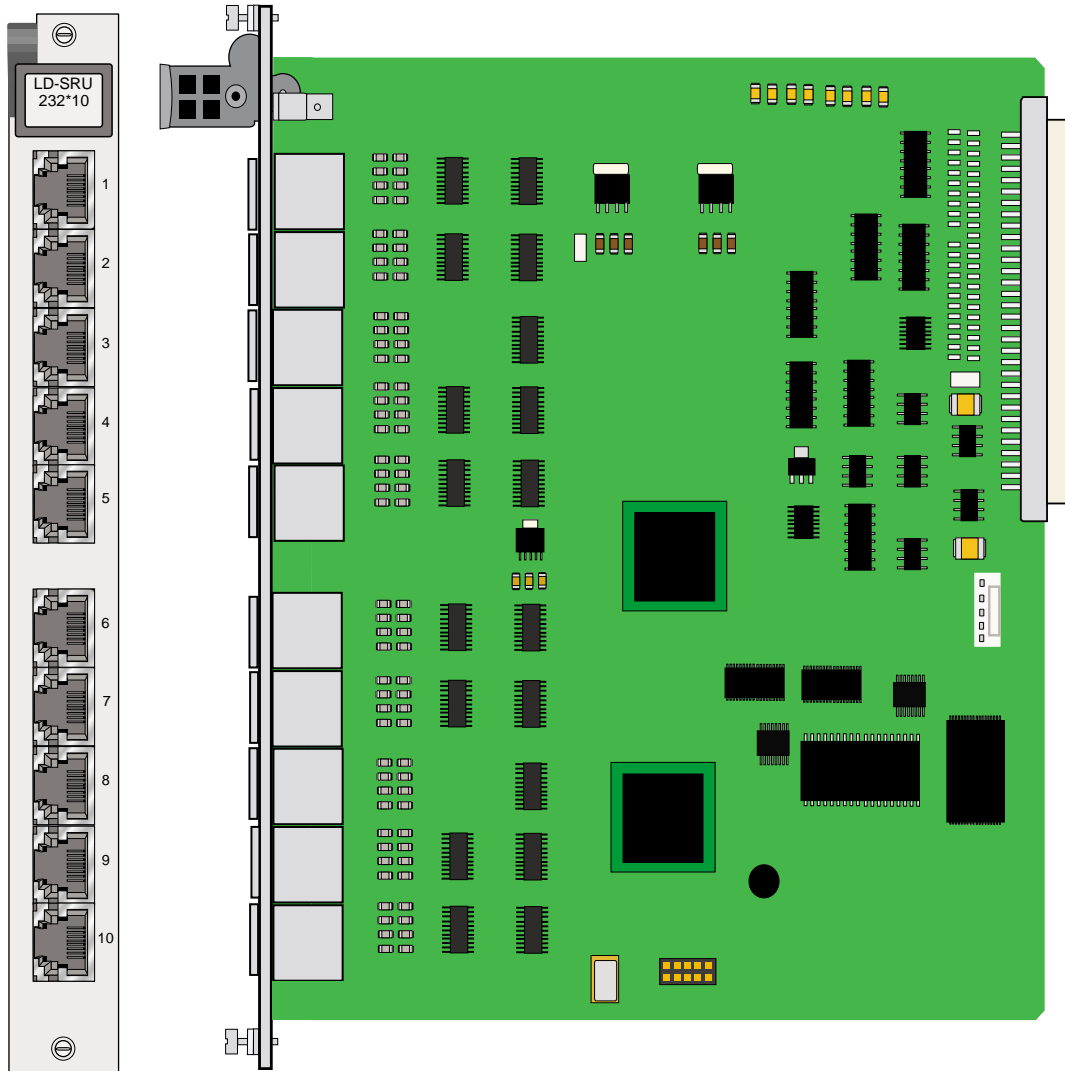

Figure 16-3.PRM-822570 LD-SRU board

16.2.3.2 Installing the LD-SRU*10 Card

Install the LD-SRU*10 Card into any user card slot. These slots are U1 to U8 on the two-sided chassis and front-loading chassis with power supplies on top, or P1 to P4 and W1 to W4 on the front-loading chassis with power supplies on the side.

16.2.4 SRU-LD*10 Card Description (822560)

The SRU-LD*10 Card allows you to connect up to ten (10) RS-232, low-speed and medium-speed data terminal to the Integrated Access System. The functionality of the SRU-LD*10 card is the same as the SRU 232*10 card with the exception of a lower delay throughput. The maximum of 3 ms +/- 10% end to end of rates 9.6 kbps or higher for sync and the maximum of 6 ms +/- 10% end to end of rates 9.6 kbps or higher for async.

16.2.4.1 Card Jumper/Switch Settings

The SRU-LD*10 Card has US/Euro jumpers or switches on its mainboard. JP2. See Figure 16-4.

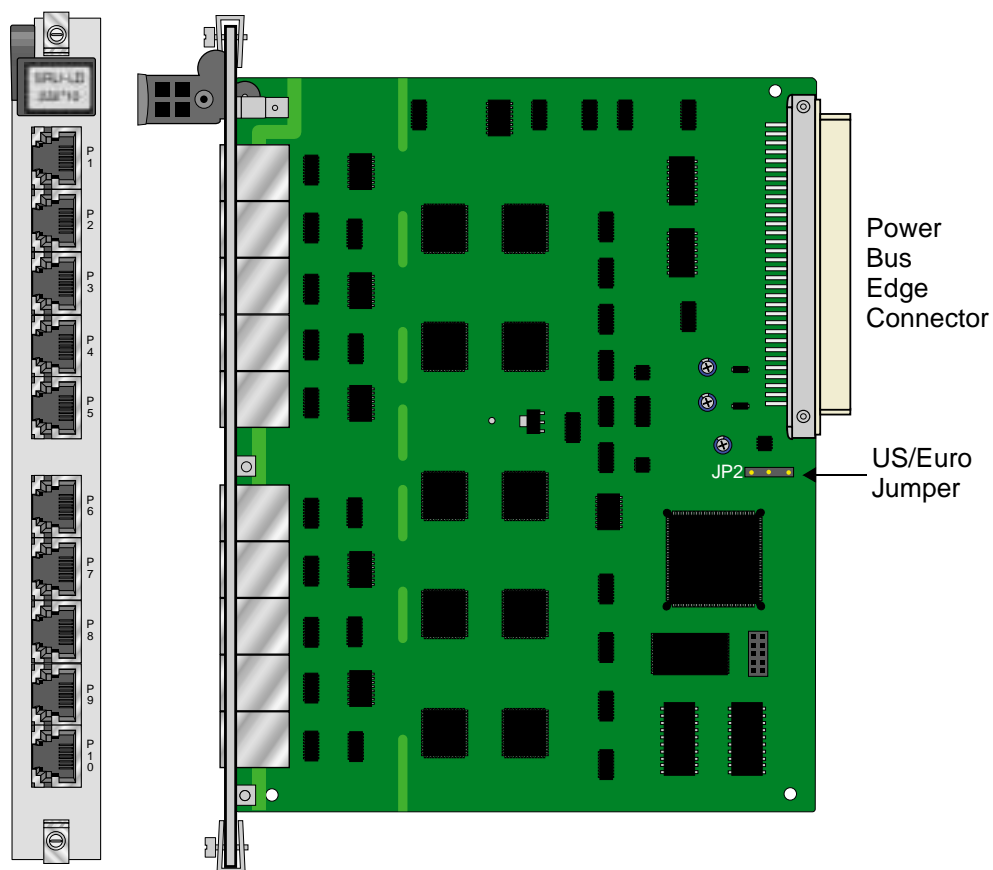

Figure 16-4.PRM-822560 SRU-LD*10 Card Jumper Settings

16.2.4.2 Installing the SRU-LD*10 Card

Install the SRU-LD*10 Card into any user card slot. These slots are U1 to U8 on the two-sided chassis and front-loading chassis with power supplies on top, or P1 to P4 and W1 to W4 on the front-loading chassis with power supplies on the side.

16.3 SRU Card User Screens and Settings

You must configure the SRU card for operation after installing it in the system chassis. This is done from the SRU Card Main Screen (Figure 16-5). To go to that screen, highlight the desired card on the System Main Screen and press <Enter>. The SRU Card Main Screen has numerous columns of data for port configuration purposes. The port numbers on the screen correspond to the card faceplate jacks from top to bottom (see Figure 16-5).

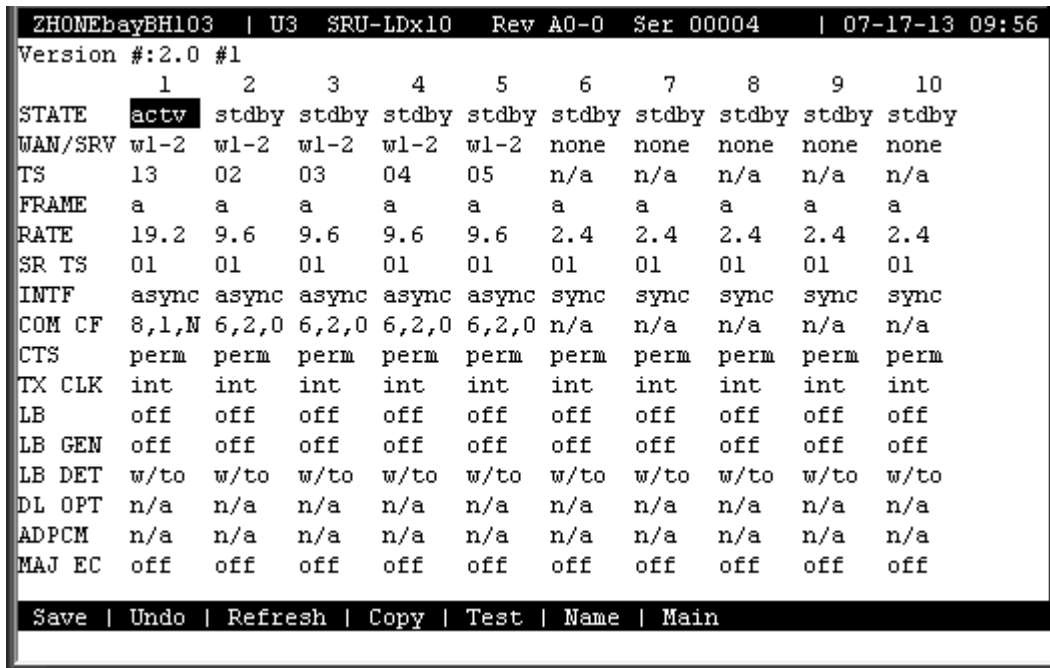

Figure 16-5. Typical SRU Card Main Screen

The highlighted bottom line of this screen shows numerous actions you can perform from this screen. To perform an action, simply press the uppercase key indicated on this line. For example, to save your option settings for this card, press “s”. Table 16-1 lists the actions you can perform.

Table 16-1. Main Screen Actions

Action	Function
Save	Saves changes to settings.
Undo	Returns all settings to the last saved state.
Refresh	Updates certain time-related information fields that are not automatically updated (i.e., test status).
Copy	Copies the contents of the current column to the next column. Useful if you change a lot of entries in one column and want to repeat those changes in subsequent columns.
Test	Initiates and monitors testing of all SRU card ports. Refer to the Test section of this chapter.
Main	Returns to the System Main Screen. If changes are made to settings and not saved, you will be prompted to save or lose changes.

Table 16-2 lists the SRU Card Main Screen parameters and available option settings.

Table 16-2. Main Screen Option Settings and Defaults

Parameter	User Options	Notes	Default
STATE	stdby act		stdby
WAN/SRV	none wan (w1-1 through w4-2) serv (P1 through P3)		w1-1
TS	01-24 01-31	1	01
FRAME	a b-5 b-10 b-20 x.50 adpcm hlink nlink		a
RATE	.3 1.2 2.4 4.8 9.6 14.4 19.2 28.8 38.4	2	.3
SR TS	n/a 1 1-5 1-10 1-20		1
INTF	asyn sync v.14		asyn
COM CF	8 7 6 5	3	8
	1 2		1
	none odd even space mark		none
CTS	perm 10 130 160 1100 r10 r13 r16 r110 off		perm
TX CLK	n/a int ext		n/a
LB	off dte net		off
LB GEN	n/a off ocu csu dsu		off
LB DET	n/a w/to on off		off
DL OPT	off on		off
ADPCM	n/a P1 P2 P3		n/a
MAJ ERR	off on none 10e-3 10e-4 10e-5 10e-6 10e-7	4	off

Notes:

- Time slot 16 is not available if the port is assigned to an E1 WAN link whose TS 16 is programmed for **cas** or **ccs**.
- The only options available for the SRU-LD*10 (8225) card are: **a**, **b-5**, **b-10**, **b-20**, **hlink** and **adpcm**.

7. Speeds of **0.3**, **1.2**, and **14.4** are not supported for synchronous channels (except 14.4 **sync** with FRAME set to **adpcm** or **hlink**).
8. Communication Configuration is a three step process. This field will show **n/a** when **sync** is chosen as the INTF option.
9. Delay Optimization is not available on SRU-LD*10 (8225) because it is already maximized for throughput.
10. Majority Error Correction is a two step process. You will only see the choices **off** and **on**. When **on** is chosen, the other alternatives will appear.

STATE

The State setting determines whether the port is active or inactive. Set this field to **stdby** (standby) for ports that are not to be used or that have not yet been configured. Set it to **actv** (active) for ports that are ready for use. The control leads assume the status shown in Table 16-3 for the different states.

Table 16-3. SRU Card State Status

Control Leads	Active	WAN Link Down	Standby
RLSD	High or follows remote RTS	Low	Low
CTS	Definable	Definable	Low

WAN

The WAN setting identifies the WAN link assigned to this port. It is not necessary for ports on the same card to be assigned to the same WAN link, or to contiguous time slots on a WAN link (see the restriction in the TS field below).

TS

The Time Slot setting identifies the time slot on the WAN link to which this port is connected. Values range from **01** to **24** for T1 links and **01** to **31** (excluding time slot 16 when CCS or CAS is used) for E1 links. The SRU card can further subdivide the WAN time slot into smaller segments for transmission of low-speed data. Each WAN time slot can be further divided into a maximum of twenty 2.4 kbps time slots (see Figure 16-6).

The only restriction to assigning WAN time slots is that the same time slot number on different WANs cannot be used for subrate data ports on the same SRU card. For example, if you assign time slot 1 on WAN 1-1 to one port on an individual card, you cannot assign time slot 1 on any other WAN link to other ports on the same card.

FRAME

The Frame setting allows you to define the sub-rate format that the port will use and to set the usable space allotted to each WAN time slot. The choices are DS0A (**a**) for one subrate time slot, DS0B with a limit of five subrate time slots (**b-5**), DS0B with a limit of ten subrate time slots (**b-10**), and DS0B with a limit of twenty subrate time slots (**b-20**). Figure 16-6 shows the DS0A and DS0B framing subrate time slot interaction. In a **b-20** frame, two or more SRU cards can be configured to occupy the same WAN time slot. These options are available with the SRU 232*10 (822060), SRU 232*10 C&D Bus (822160), SRU-422*4 (822460) and SRU-LD*10 (822560) cards.

Additional choices with the SRU 232*10 (822060), SRU 232*10 C&D Bus (822160), and SRU-422*4 (822460), cards include: **x.50** (an ITU standard), **nlink** (used to transmit clock to related units) (Note: the RATE and INTF will change when **nlink** is chosen), and with the SRU-LD*10 (822560) card: **adpcm** (used to multiplex subrate data on an ADPCM card) and **hlink** (a proprietary format used when far end of the circuit has an ADPCM card while the near end does not). The **adpcm** frame uses a 24 kbps portion of the ADPCM engine.

RATE

The Rate setting allows you to select the rate in kilobits per second (kbps) for data transmission. The selection will change depending upon the framing mode and interface selected. Figure 16-6 shows the bandwidth available for each selection.

The maximum total bandwidth of an 8220 or 8221 SRU card cannot exceed 115.2 kbps. The 8225 cards do not have this limitation.

The maximum bandwidth of the card depends upon the mode of operations for each port. The maximum bandwidth for the **sync** Interface setting is 115.2 kbps and the host will not allow more than this to be assigned.

The maximum bandwidth for **async** and **v.14** is harder to compute because the computation depends upon the amount of data being sent.

The **async** ports have a minimum multiplication factor of 1.2 times a **sync** port, and **v.14** has a multiplication factor of 1.6 times that of a **sync** port. Using the Delay Optimization feature will also degrade the maximum bandwidth by a factor of 1.5 times the maximum bandwidth figure.

These computation factors suggest a maximum of 96 kbps (96 kbps x 1.2 = 115.2 kbps) for **async** ports and 72 kbps (72 kbps x 1.6 = 115.2 kbps) for **v.14** ports. However, because of the nature of **async** and **v.14** data transmission, these limits are not fixed because the user will not be transmitting data at the full rate. The Delay Optimization feature also degrades the maximum bandwidth by a factor of 1.5 times the total bandwidth. BERT adds another 2x multiplication factor to the data rates shown above. These limitations do not apply to the PRM-822560 and PRM-822570 LD-SRU cards.

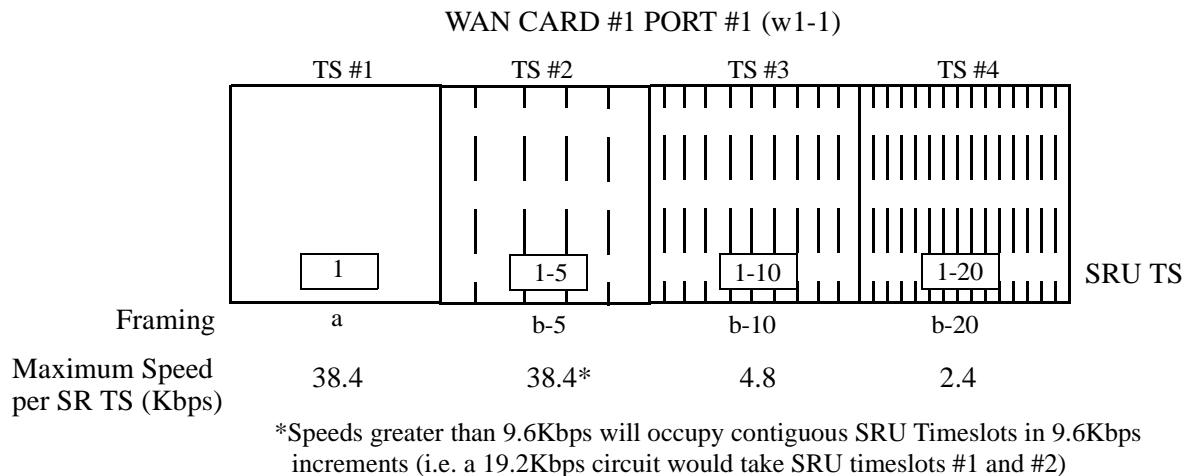

Figure 16-6.SRU Time Slot Integration

SR TS

The Subrate Time Slot (SR TS) indicates the subrate position within the DS0 time slot the port will occupy (see Figure 16-6). If **a** framing is selected, only one subrate time slot is supported and the SR TS setting will default to 1. If **b-5** framing is selected, the available subrate time slots are 1 to 5. If **b-10** framing is selected, the available subrate time slots are 1 to 10. If **b-20** framing is selected, the available subrate time slots are 1 to 20. Portions of subrate time slots can be assigned to any SRU port from any SRU card in the system (see the configuration example later in this chapter). If **adpcm** or **hlink** are chosen for the frame parameter, this field will show **n/a**.

In **b-5** framing, if circuits with speeds greater than 9.6 kbps are assigned to the subrate time slot, adjacent subrate time slots must be available to accommodate their size. A 19.2 kbps circuit would occupy two contiguous subrate time slots (leaving space for up to three 9.6 kbps circuits) and a 38.4 kbps circuit would occupy four contiguous subrate time slots (leaving space for one 9.6 kbps circuit).

The SR TS number selected will be the first segment occupied by this circuit. If a 28.8 kbps circuit occupies three segments of the **b-5** frame, selecting SR TS 1 will assign it to segments 1, 2 and 3. Segments 4 and 5 may be assigned either independently to 9.6 (or less) kbps circuits in SR TS 4 and 5 or combined for a 19.2 kbps circuit assigned to SR TS 4.

If a circuit exceeds the slots necessary to accommodate it, such as a 38.4 kbps circuit to SR TS 3 in **b-5** framing, the message "Invalid SR TS" will be displayed. If a circuit requires more space than the SR TS has available, such as having a 38.4 kbps circuit in SR TS 1 and then attempting to assign a 19.2 kbps circuit to SR TS 4, the message "SR TS overlapping" will be displayed.

The number of subrate time slots available for **x.50** depend on the selected Rate. If the **2.4** Rate is selected, the number available will be 20. If the **4.8** Rate is selected, the number available will be 10. If the **9.6** Rate is selected, the number available will be 5. When multiplexing different rate circuits on the same time slot, the following formula is necessary to compute the position in the sub-rate time slot: a 9.6 kbps circuit will occupy slots n, n+5, n+10, and n+15. Similarly, a 4.8 kbps circuit will occupy slots n and n+10, and a 2.4 kbps circuit will occupy slot n (where n is the time slot selected).

INTF

The Interface setting allows you to choose the protocol necessary for the terminal associated with this port. The choices are **asyn** (Asynchronous), **sync** (Synchronous), and **v.14** (v.14). If Synchronous transmission is selected, the choices for STOP, DATA and PAR will show as **n/a** (not applicable).

Both **asyn** and **v.14** options provide asynchronous to synchronous conversion. The **v.14** option is an industry standard which will allow the card to operate with many DSUs. The **asyn** option is a streamlined proprietary algorithm which will increase the performance of the card.

COM CF

The Communication Configuration setting is a three-step process that allows you to choose the Data bits, Stop bits, and Parity to be used. The Data setting allows you to change the bits-per-byte number depending upon the type of terminal associated with this particular port. The options are **8**, **7**, **6**, and **5**.

The Stop bits option allows you to select the number of Stop bits that check data sampling for the terminal associated with this port. The options are **1** and **2**.

The third choice is the Parity setting that changes the data parity for the terminal associated with this port. The options are **none**, **odd**, **even**, **space** and **mark**.

CTS

The Clear To Send (CTS) setting allows you to define how the port should respond upon receiving a Request to Send (RTS) from the attached DTE. This setting also allows you to change the delay time (in milliseconds) from when the card receives RTS until it issues CTS. The local option allows RTS to control CTS. The remote-local options allows RTS to control both the CTS of the local equipment and RLSD of the remote equipment. The options are **perm** (permanent), **l0** (local-immediate), **l30** (local - 30 ms), **l60** (local - 60 ms), **l100** (local - 100 ms), **rl0** (remote/local - immediate), **rl3** (remote/local - 30 ms), **rl6** (remote/local - 60 ms), **rl10** (remote/local - 100 ms), and **off**.

TX CLK

The Transmit Clock setting allows you to choose the timing source for this port. The options are **n/a** if **async** interfacing is chosen and **int** (internal), if **sync** interfacing is chosen. The **int** setting uses the Integrated Access System as the clock source, and **ext** allows the DTE to generate transmit timing with EXT ports are grouped: 1,2 / 3,4,5,6 / 7,8,9,10.

LB

The Loopback setting allows you to activate local loopbacks on the SRU card. These settings are **off**, toward the **dte** (DTE), and toward the **net** (network). Figure 16-7 shows a diagram of the local loopback conditions.

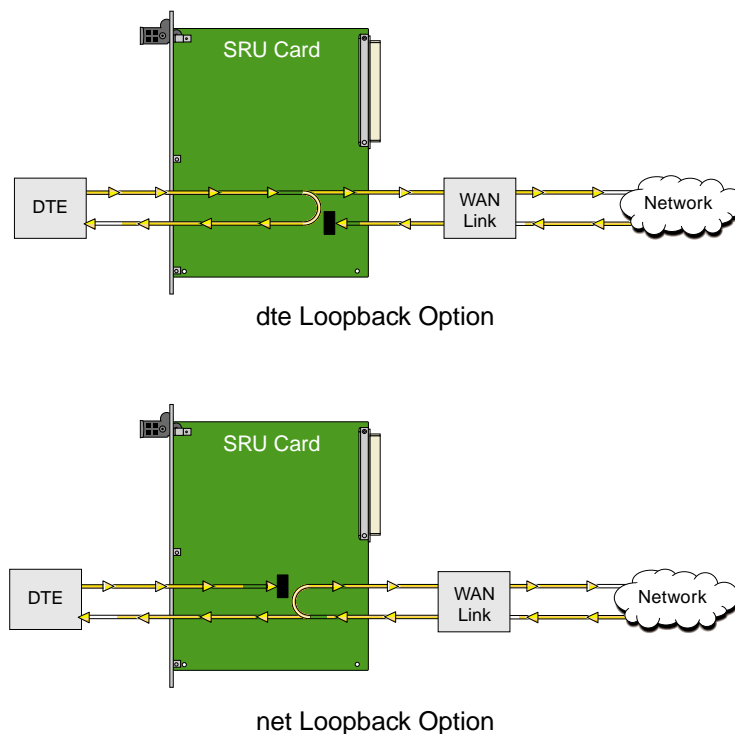

Figure 16-7. Local Loopbacks

LB GEN

The Loopback Generate setting generates inband diagnostic codes that are sent to the remote equipment. These codes are compatible with DDS networks, and allow you to command a latching loopback at remote DDS equipment. You can start loopbacks at the remote **ocu** (Office Channel Unit), **dsu** (Data Service Unit), or **csu** (Channel Service Unit). Figure 16-8 through Figure 16-10 show the loopbacks locations. You can also turn each loopback **off**. This field shows **n/a** if **adpcm** or **hlink** are chosen for the Frame parameter.

Note that loop-up and loop-down commands cannot be implemented for two ports of the same card simultaneously. You must finish all loopback operations on one port before attempting them on another port.

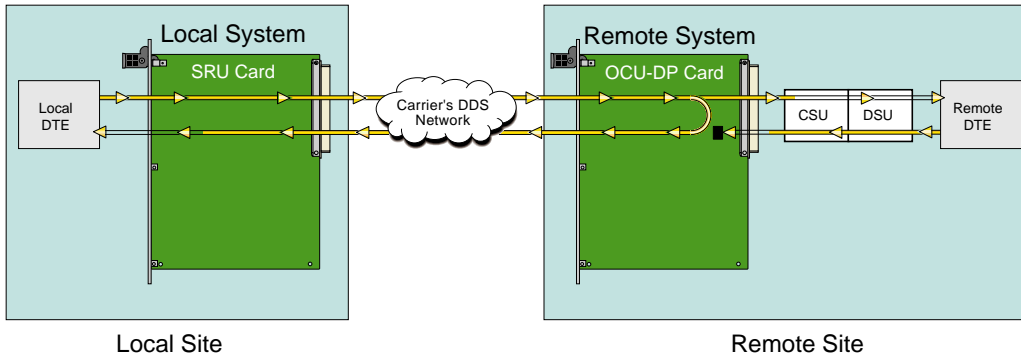

Figure 16-8. Inband Remote SRU Loopback

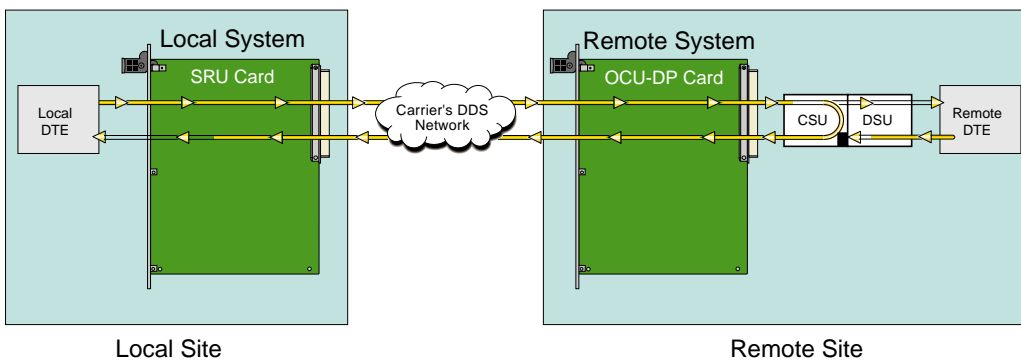

Figure 16-9. Inband Remote CSU Loopback

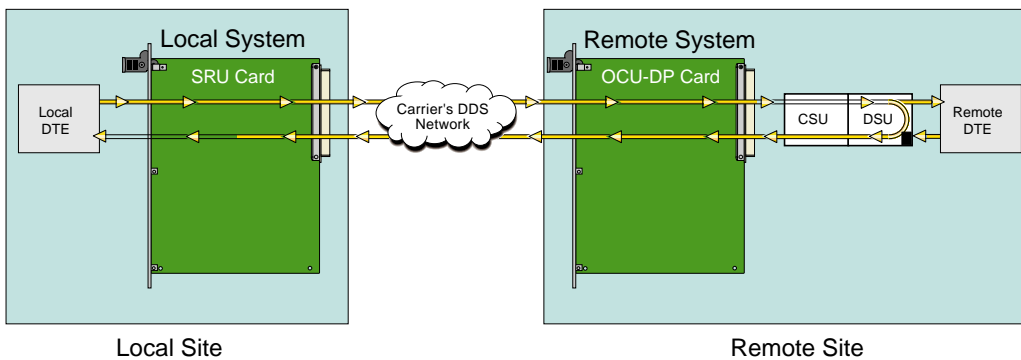

Figure 16-10. Inband Remote DSU Loopback

LB DET

The Loopback Detection setting determines how the card will respond to latching and non-latching loopback commands from remote equipment. The SRU reacts only to the inband DDS-format loopback commands for OCU Loop, CSU Loop, and DSU Loop. The Loopback Detection setting does not affect local loopback commands from the local control terminal.

The **on** option causes the card to monitor ports for DDS format loopback commands from the remote equipment. If the card detects a loopback command, it loops the data back until the remote equipment sends a stop loopback command. The **w/to** (with time-out) option is the same as the **on** option, except that after ten minutes the SRU card automatically releases loopbacks commanded by the remote equipment. The **off** option causes the SRU card to ignore all remote loopback commands. This field will show **n/a** if **adpcm** or **hlink** are chosen for the FRAME parameter.

DL OPT

Delay Optimization decreases the end-to-end delay time for applications that require lower delay time. The options are **off** and **on**.

The cost of using Delay Optimization is a decrease in total bandwidth for the card by a factor of 1.5. For example, a customer that has 10 ports using the sync Interface will have a 115.2 kbps maximum bandwidth. If delay optimization is used on all 10 ports, the maximum bandwidth will be 76.8 kbps.



*Note: This option doesn't apply for SRU-LD*10 (822560) card.*

ADPCM

If **adpcm** is chosen as the Frame parameter, this field allows you to select the ADPCM card to direct this traffic. The ADPCM card options are **P1**, **P2** and **P3** (the resource card slot designations stamped on the chassis). If any other option is selected, this field will show **n/a**.

MAJ EC

The Majority-Vote Error Correction parameter is available for ports using DS0A framing at speeds of 9.6 kbps and lower. This option selection is a two-step process. The initial options are **off** and **on**. If the **on** option is chosen, a new set of options will appear at the bottom of the screen.

The new options are used to select the error threshold, above which the card will generate an alarm. The choices are **none**, **10e-3**, **10e-4**, **10e-5**, **10e-6**, and **10e-7**. While the majority vote algorithm is capable of correcting error rates in excess of 10e-3, the Excessive Error Rate alarm gives system administrators advanced notice of problems before users detect them. Table 16-4 shows the bit error rates for majority-vote error correction.

Table 16-4. Bit Error Rates for Majority-Vote Error Correction

Threshold	EER Set	EER Reset	Period
none	none	none	none
10e-3	64 or more errors	63 or less errors	1 second
10e-4	64 or more errors or any of the above	63 or less errors	10 seconds
10e-5	38 or more errors or any of the above	37 or less errors	60 seconds
10e-6	3 or more errors or any of the above	2 or less errors	60 seconds
10e-7	17 or more errors or any of the above	16 or less errors	three 15 minute time intervals

16.4 Card Configuration Examples

Figure 16-11 shows ways in which SRU cards can be used to network low-speed data with DS0A and DS0B framing. In this diagram, five cards are connected to eight WAN time slots of one WAN port on one WAN card (many combinations of cards/ports/time slots are possible). Each card is separated to show the ten ports on each card. Each port is assigned to a low-speed data device, and the transmission speed of that device is shown in the center of the SRU data port.

Note that the diagram sometimes shows only one connection, in order to eliminate unnecessary lines in the diagram. Each port is a direct connection and does not support interchange of data transmission between ports.

The first time a WAN card/port/time slot is used, the framing selected on the SRU card port will segregate that WAN time slot into SRU time slots. Once selected, those SRU TSs will apply to all ports assigned to that WAN time slot.

Once the framing is selected for the WAN card/port/time slot, low-speed data devices can be arranged and selected on the SRU card settings to maximize the system capabilities.

In this example, the first port on SRU 1 assigned **a** framing to WAN 1-1, TS 1, and selected a 38.4 kbps device for its use. The second port has **b-5** framing to WAN 1-1, TS 2. Of the five SRU time slots on that WAN time slot, the first three are used to support a 28.8 kbps device (three 9.6 kbps contiguous SRU time slots). The 9.6 kbps device on SRU 1, port 3 occupies the fourth SRU time slot and another 9.6 kbps from SRU 3, port 10 is placed in the fifth slot.

WAN 1-1, TS 3 was segregated into ten SRU time slots by the selection of **b-10** framing, which supports 0.3, 1.2, 2.4, or 4.8 kbps transmission. Six 4.8 kbps ports are assigned to the first six SRU time slots. *The diagram shows only one connection to eliminate unnecessary lines in the diagram. The six ports are six direct connections and will not support interchange of data transmission.* The other four SRU time slots are used by ports 1 to 4 on SRU 4. *Again, the single line does not imply interexchange.*

WAN 1-1, TS 4 has **b-20** framing and will support up to twenty 0.3, 1.2 or 2.4 kbps circuits from two (or more) SRU cards. In this example, SRU 1, port 10 is assigned to SRU TS 1, SRU 2, ports 1-10 are assigned to SRU TS 2 to 11. The nine SRU time slots left are used by SRU 3, ports 1-9. As mentioned earlier, SRU 3, port 10 is a 9.6 kbps circuit assigned to WAN 1-1, TS 2, SRU time slot 5. WAN 1-1, TS 5, has **a** framing. Only one device can transmit data in this SRU time slot. In this example, a 2.4 kbps circuit was assigned to SRU 4, port 5.

WAN 1-1, TS 6 has **b-5** framing, so five SRU time slots are available. The first two 9.6 kbps slots are used by a 19.2 kbps circuit on SRU 4, port 6, while the other three are used by 9.6 kbps circuits on SRU 4, ports 7 to 9.

WAN 1-1, TS 7 has the same characteristics as TS 6, except that the first SRU time slot is used by a 9.6 kbps circuit on SRU 4, port 10, SRU time slots 2-4 are assigned to the single 28.8 kbps port on SRU 5. WAN 1-1, TS 8 was designated as **b-10** framing and the first eight SRU time slots are associated with the 2.4 and 4.8 kbps circuits on SRU 5, ports 3 to 10.

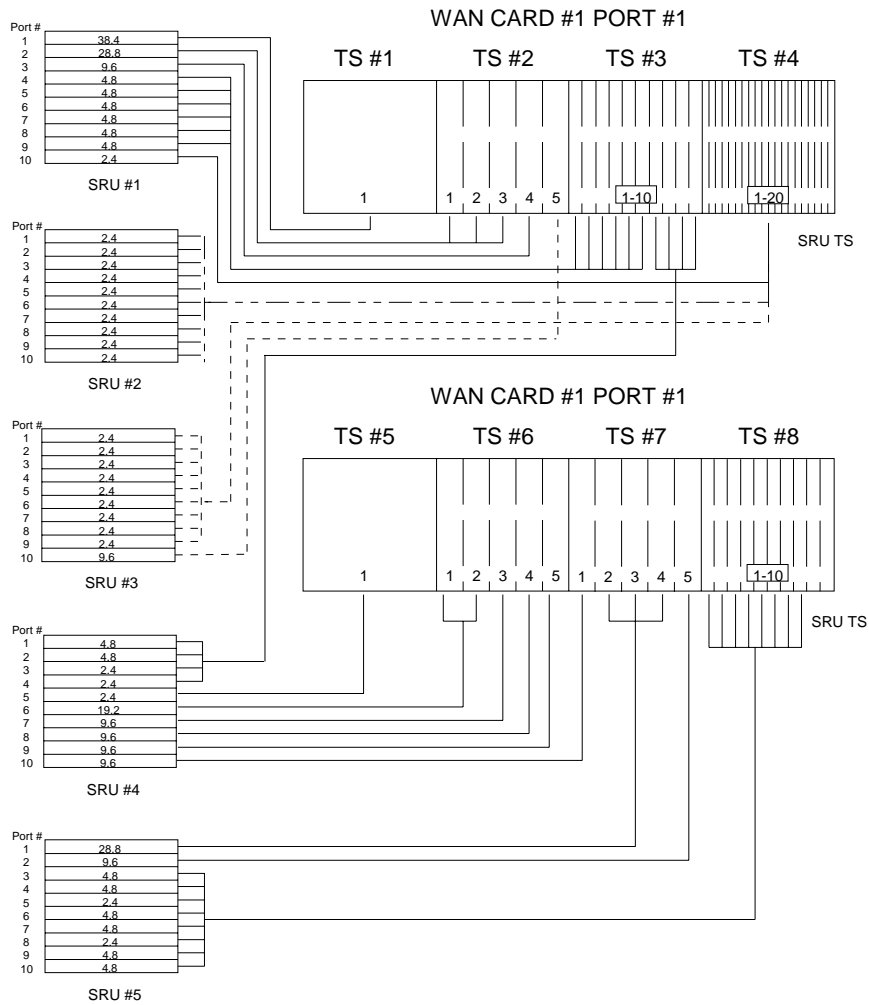

Figure 16-11. Typical WAN Time Slot Assignments to an SRU Card

16.5 Test Screen

Pressing “t” (Test command) in the SRU Card Main Screen will bring up the Test Screen shown in Figure 16-12. From this screen, you can create test situations between SRU cards, or between a single card and data test equipment at a remote site.

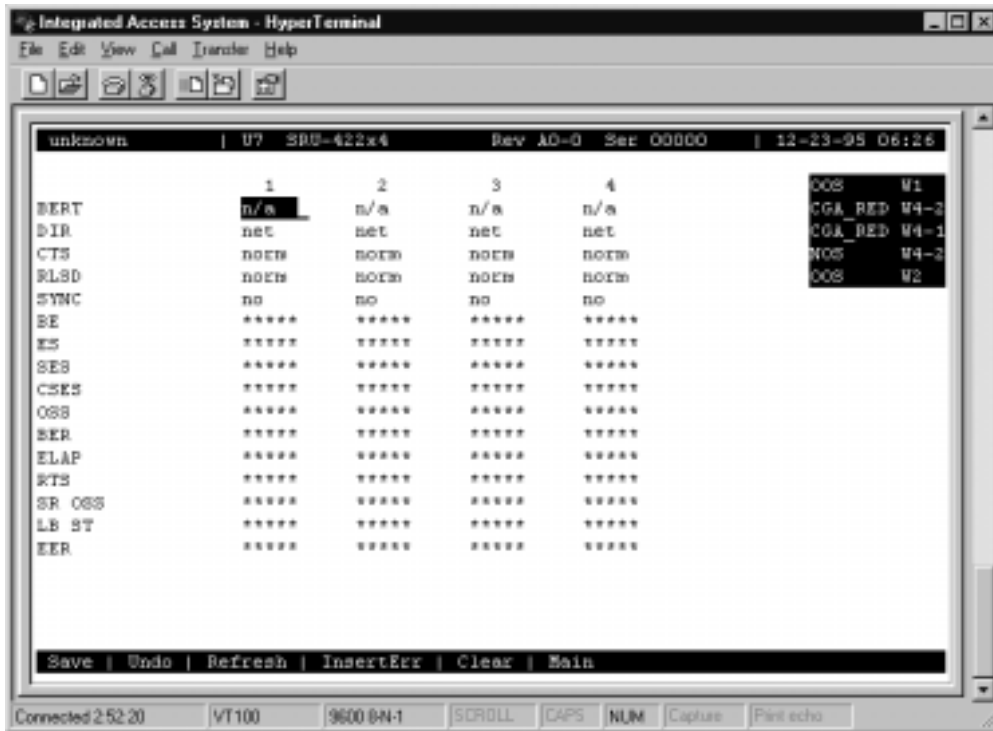

Figure 16-12. Typical SRU Card Test Screen

The bottom highlighted line of the Test Screen shows some actions you can perform from this screen. To perform an action, just press the uppercase key for the desired choice. Table 16-5 lists these actions, and Table 16-6 lists the settings in the Test Screen, along with their possible and default values. These settings are also described in the following paragraphs.

Table 16-5. Test Screen Actions

Action	Function
Save	Saves changes to settings.
Undo	Returns all settings to the last saved state.
Refresh	Updates certain time-related information fields that are not automatically updated (i.e., test status).
InsertErr	Allows you to manually insert a single error into the clear data signal.
Clear	Clears the Test Screen and resets all counters to zero.
Main	Returns to the SRU Card Main Screen. If changes are made to settings and not saved, you will be prompted to save or lose changes.

Table 16-6. Test Screen Option Settings and Defaults

Parameter	User Options	Default
BERT	off mark space 1:1 1:7 511 qrss 2047	off
DIR	net user	net
CTS	norm off on	norm
RLSD	norm off on	norm
SYNC	information only—no user options	*****
BE	information only—no user options	*****
ES	information only—no user options	*****
SES	information only—no user options	*****
CSES	information only—no user options	*****
OSS	information only—no user options	*****
BER	information only—no user options	*****
ELAP	information only—no user options	*****
RTS	information only—no user options	*****
SR OSS	information only—no user options	*****
LB ST	information only—no user options	*****
ERR	information only—no user options	*****

BERT

Bit Error Rate Tester (BERT) sends a data pattern and measures the bit error rate (BER) on the selected SRU port. The patterns that can be selected are **off**, **mark** (all ones), **space** (all zeros), **1:1** (alternating 10101010), **1:7** (10000000), **511** (511 test pattern), and **2047** (2047 test pattern).

DIR

The Direction (DIR) setting allows you to specify where the BERT test signal should be directed. The first option is **net** (network) which means that the test signal will be transmitted through the system toward the Wide Area Network (WAN). The **user** option means that the signal will be directed toward the attached DTE device over the RS-232 interface.

CTS

The Clear To Send (CTS) option allows you to define whether the CTS control lead should be held **on** (high) or **off** (low). Selecting either **on** or **off** will override the selection made in the SRU Card screen. The third option is **norm** (normal) which means that CTS will behave as described in Table 16-3.

RLSD

The Receive Level Signal Detect (RLSD) option allows you to define whether the RLSD control lead should be held **on** (high) or **off** (low). The third option is **norm** (normal) which means that RLSD will behave as described in Table 16-3.

SYNC

The Synchronization (SYNC) field tells you if the integrated BERT has achieved synchronization either with itself via a remote loopback or with the remote test equipment. Since this is an information-only field, there are no user-selectable parameters.

BE

The Bit Error field shows the total number of bit errors logged. Since this is an information-only field, there are no user-selectable parameters.

ES

The Errored Seconds field shows the total number of seconds in which any errors were detected. Since this is an information-only field, there are no user-selectable parameters.

SES

The Severely Errored Seconds (SES) field shows the total number of seconds in which the bit error rate exceeded one bit per thousand (1×10^{-3}). Since this is an information-only field, there are no user-selectable parameters.

CSES

The Consecutive Severely Errored Seconds (CSES) field is triggered by the occurrence of ten consecutive Severely Errored Seconds. Once triggered, the CSES field will increment (by one) for each elapsed second until the system logs ten consecutive non-Severely Errored Seconds. Since this is an information-only field there are no user-selectable parameters.

OSS

The Out of Synchronization Seconds field shows the number of seconds that the SRU BERT has been out of synchronization. Since this is an information-only field, there are no user-selectable parameters.

BER

The Bit Error Rate (BER) field shows the rate at which errors are being logged. The system calculates BER by dividing the number of bit errors (BE) by the total number of bits transmitted during the test. Since this is an information-only field, there are no user-selectable parameters.

ELAP

The Elapsed time setting shows the running tally of the total number of seconds during the test. Since this is an information-only field, there are no user-selectable parameters for this option.

RTS

The Request To Send (RTS) field shows the current status of the RTS control lead. The two values that can be displayed are **on** and **off**. Since this is an information-only field, there are no user-selectable parameters for this option.

SR OSS

The Subrate Out of Synchronization Seconds (SR OSS) field shows how many seconds in which there was a Subrate framing loss. Since this is an information-only field, there are no user-selectable parameters for this option.

LB ST

The Loopback State (LB ST) field indicates whether there are any remotely-initiated loopbacks currently active on the SRU port. This field will display both latching and non-latching loopbacks that are initiated from a remote device via in-band loop-up codes. In addition to **none**, the six possible messages that can be displayed in that field are **l-ocu**, **l-dsu**, and **l-csu** for latching loopbacks; or **ocu**, **dsu**, and **csu** for non-latching loopbacks. Since this is an information-only field, there are no user-selectable parameters for this option.

EER

The Excessive Error field will display the computed the DS0 error rate for each port where that option was selected. The Majority Error Rate will be computed based on the integration period for the selected threshold. For example, if the $10e-4$ threshold was selected, the integration would be 10 seconds.

16.6 SRU Card Error Messages

Refer to Appendix B in the System Reference Guide for further information on Error Messages regarding this card.

16.7 SRU Card Troubleshooting

SRU card problems could indicate a number of possible causes, including:

- Faulty receiving DTE at the near end (where the problem was first noticed)
- Faulty transmitting DTE at the far (opposite) end
- Faulty cabling between the DTE and SRU card at the near end
- Faulty cabling between the DTE and SRU card at the far end
- T1 or E1 network failure
- Improper card configuration at either end (e.g., time slot and/or WAN port assignments)

Typically, a problem is indicated by a loss of incoming signal on a data port at either end of the circuit. You can perform numerous tasks to isolate the trouble and clear it. When troubleshooting transmission problems on a data circuit passing through an SRU card, follow this general sequence:

1. If all ports are affected, verify that the US/EUR jumper is correctly placed to match the US/EUR jumper on the chassis.
2. Verify that the T1 or E1 network is working properly by checking for current CGA-Red and CGA-Yellow alarms. If the network is faulty, the same transmission problem may exist with the other ports of the same SRU card, and also with the data ports of all other data cards connected to the same T1 or E1 line. If no CGA alarms are present, continue with step 3.
3. Verify that the DS0 time slot and sub-rate TS assignments of the faulty port at both ends of the data circuit path are correct. Also be sure the port is connected to the proper WAN card and port and that other critical parameters, such as **RATE**, are set the same at each end. If these assignments are correct, continue with step 4.
4. At the local end (where the incoming data loss was first observed), use the loopback and test signal functions of the SRU card to test the affected port. These tests are accessible from the SRU Card Main Screen (through the **LB** and related parameters) and its associated Test Screen (through the **BERT** parameter), as previously described in this chapter. These allow you to test the circuit path in segments and thereby quickly pinpoint the problem.

5. If necessary, also perform loopbacks and send test signals to the affected circuit from the other end. In addition, you can perform end-to-end tests using a suitable data test set at one or both ends of the circuit in conjunction with the loopback functions of the SRU card at either end.
6. If the SRU card is determined to be faulty, replace it and return the faulty unit for repair to the location specified by your distributor.

16.8 SRU Card Specifications

SRU Card (Models 822060 and 822160)

Number of Ports	10
Physical Interface	female 8-pin RJ-48
Electrical Interface	RS232C, ITU-T V.28
Operational Interface	DCE - Full Duplex
Interface Settings	Asynchronous, Synchronous, V.14
Sub-rate Framing Format	X.50, V.14, DS0-A, DS0-B with 5, 10, or 20 divisions per DS0
Sub-rate Time slot Number	1 through 20 depending on Sub-rate Framing Format

Synchronous Data

Format	Transparent
Transmit Clocking	Software selectable per port; internal or external
Speeds	2.4, 4.8, 9.6, 14.4, 19.2, 28.8 and 38.4 kbps

Asynchronous Data

Format	V.14 or proprietary
Stop Bits	Software selectable per port; 1 or 2
Data Bits	Software selectable per port; 5, 6, 7 or 8
Parity	Software selectable per port; none, odd, even, space or mark
Speeds	.3, 1.2, 2.4, 4.8, 9.6, 14.4, 19.2, 28.8 and 38.4 kbps

Signaling

DSR	Tied to DTR
CTS	Software selectable per port; on, off (tied to RTS)
CTS delay	Software selectable per port; immediate, 30, 60 or 100 ms
RLSD	Software selectable per port; permanently on, follows remote RTS (drop on receipt of IDLE or CGA RED)

Diagnostics & Alarms

BERT	Integral
Direction	Toward DTE or toward Network
Data Patterns	Off, mark, space, 1:1, 1:7, 511, 2047 zeros

Loopbacks

Local	Toward DTE or toward Network
Remote - Generation	Inband, latching, DDS format at CSU, DSU or OCU-DP
Remote - Detection	Inband, latching and non-latching DDS Format for OCU Loop, CSU Loop and DSU Loop. Optional automatic ten (10) minute timeout

Error Correction

Majority Vote Error Correction	Available for DS0-A ports operating at 9.6 Kbps or less, triggers EER ALARM when specified threshold is exceeded
Majority Vote Error Thresholds	None, 10e-3, 10e-4, 10e-5, 10e-6 or 10e-7

Standards Compatibility

Bellcore	GR-63-CORE Issue 1	Network Equipment-Building System (NEBS) Requirements: Physical Protection
AT&T	TR 54075	Subrate Data Multiplexing - A Service of DATAPHONE Digital Service
ITU-T	V.28	Electrical characteristics for unbalanced double-current interchange circuits
	X.50 Division 3	Fundamental Parameters of a Multiplexing Scheme for the International Interface Between Synchronous Data Networks (note: does not support 600 bps data)
	V.14	Transmission of Start-Stop Characters over Synchronous Bearer Channels (using async to sync converters)
EIA	RS 232	Interface Between DTE and DCE Employing Serial Binary Data Interchange
UL	1950	UL Standard for Safety of Information Technology Equipment
CEN	EN 500 081-1	Electromagnetic compatibility generic emission standard Part 1 Residential, commercial and light industry
	EN 500 082-1	Electromagnetic compatibility generic immunity standard Part 1 Residential, commercial and light industry
	EN 50 950/A2	Safety of information technology equipment including electrical business equipment

Chapter 17

OCU-DP Card

17.1 Introduction

This chapter provides installation, configuration, and troubleshooting information for the Office Channel Unit - Dataport (OCU-DP) Cards. These are labeled as the OCU-DP 2, OCU-DP 5 and OCU-DP 10 Cards on their faceplate ejectors.

This chapter also provides installation information for the OCU-DP port activation card, which is used on the OCU-DP 5 Card.

The Integrated Access System uses OCU-DP cards to interface directly with Data Service Units/Channel Service Units (DSU/CSUs) supporting data traffic up to and including 64 kbps. A four-wire circuit can connect the OCU-DP card to a DSU/CSU up to four miles away. In the Switched 56 kbps mode, customers access the network on an as-needed basis via dial-up commands. The system must be equipped to provide -48 VDC power to fully support the OCU-DP card.

17.2 OCU-DP Card Descriptions

17.2.1 OCU-DP 5 Card Description (824160)

The OCU-DP 5 Card is a 5 port card which allows provisioning of DDS services or consolidation of DSU traffic as DS0-A or DS0-B. Interfaces directly to DSU at speeds up to and including 64Kbps. Does not support BCH error correction, performance monitoring or operation in CSU mode (used only for back-to-back OCU-DP ports). Each port may be connected to a DSU/CSU operating at 64, 56, Switched 56, 19.2, 9.6, 4.8 or 2.4Kbps. DSUs can be local to several thousand feet distant to the Integrated Access System based on speed and wire gauge.

17.2.1.1 Card Jumpers/Switch Settings

The OCU-DP 5 Card doesn't have any jumpers or switches on its mainboard.

17.2.1.2 Installing the OCU-DP 5 Card

Install the OCU-DP 5 Card in any user card slot. These slots are U1 to U8 on the two-sided chassis and front-loading chassis with power supplies on top, and P1 to P4 or W1 to W4 on the front-loading chassis with power supplies on the side.

17.2.2 OCU-DP 2 Card Description (8249)

The OCU-DP 2 Card has only two ports. Each card may be connected to a DSU/CSU operating at one of the rates stated above for the OCU-DP 5 Card. In addition, the OCU-DP 2 supports BCH error correction, performance monitoring, and the CSU operating mode.

17.2.2.1 Card Jumpers/Switch Settings

The OCU-DP 2 Card does not have any jumpers or switches on its mainboard.

17.2.2.2 Installing the OCU-DP 2 Card

Install the OCU-DP 2 Card in any user card slot. These slots are U1 to U8 on the two-sided chassis and front-loading chassis with power supplies on top, and P1 to P4 or W1 to W4 on the front-loading chassis with power supplies on the side.

17.2.3 OCU-DP 10 Card Description (824660)

The OCU-DP 10 Card supports up to ten data ports operating at speeds up to 64 kbps inclusive. This card interfaces directly with DSU/CSUs which can be located up to 4 miles away.

17.2.3.1 Card Jumpers/Switch Settings

The OCU-DP 10 Card does not have any jumpers or switches on its mainboard.

17.2.3.2 Installing the Card

Install the OCU-DP 10 Card in any user card slot. These slots are U1 to U8 on the two-sided chassis and front-loading chassis with power supplies on top, and P1 to P4 or W1 to W4 on the front-loading chassis with power supplies on the side.

17.3 OCU-DP Card User Screens and Settings

17.3.1 OCU-DP Card Main Screen

You must configure the OCU-DP Card for proper operation. This is done from the OCU-DP Card Main Screen, which is shown in Figure 17-14. To go to this screen, highlight the desired card in the System Main Screen and press <Enter>.

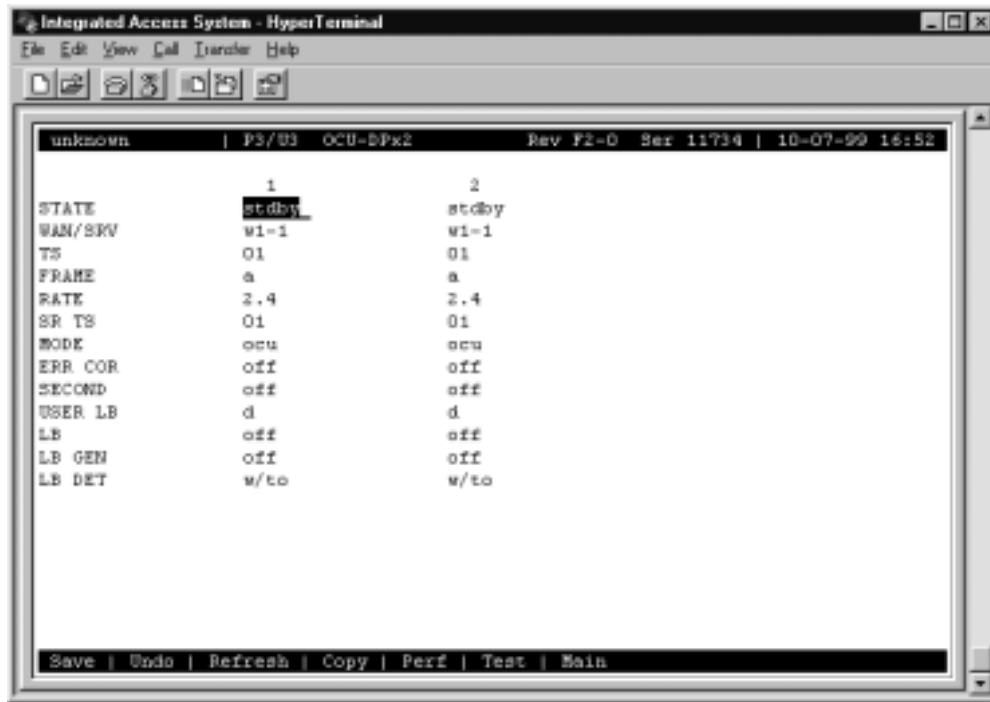

Figure 17-1. Typical OCU-DP Card Main Screen

The bottom highlighted line of this screen lists various actions that you can perform from this screen. To perform an action, simply type the uppercase letter corresponding to the desired action on this line. For example, to save your card option settings, press “s” to invoke the **Save** command. Table 17-1 lists the actions you can perform from this screen, and Table 17-2 lists the OCU-DP Card Main Screen parameters and available settings. These are also described in the following paragraphs.

Table 17-1. Main Screen Actions

Action	Function
Save	Saves changes to settings.
Undo	Returns all settings to the last saved state.
Refresh	Updates certain time-related information fields that are not automatically updated (i.e., performance and test data).
Perf	Brings up the Performance Data Screen.
Test	Initiates and monitors testing of all OCU-DP card ports. Refer to Test section of this chapter.
Main	Returns to the System Main Screen. If changes are made to settings and not saved, you will be prompted to save or lose changes.

Table 17-2. Main Screen Option Settings and Defaults

Parameter	User Options	Notes	Default
STATE	stdby actv		stdby
WAN/SRVsrv	wan (w1-1 through w4-2) serv (P1 through P3)		w1-1
TS	01-24 01-31		01
FRAME	a b-5 b-10 b-20		a
RATE	2.4 4.8 9.6 19.2 56k 64k sw56k	1	2.4
SR TS	01 01-05 01-10 01-20		01
MODE	ocu csu		ocu
ERR COR	off maj-v bch	21	off
SECOND	n/a off on		off
USER LB	d o		d
LB	off dte net-d net-a		off
LB GEN	off ds0-n ocu-n csu-n csu-u		off
LB DET	w/to on off		w/to

Notes:

1. When the WAN/SRV option is set to **P1**, **P2**, or **P3** (Server cards), the only valid options for RATE are **56K** and **64K**.
2. The **maj-v** option is supported on all cards if the Rate is **2.4**, **4.8** or **9.6**. Error Correction is not supported if the Rate is **sw56k**. BCH Error Correction is not supported on the 5-port and 10-port OCU-DP card. The BCH algorithm is supported only at 19.2, 56, and 64 kbps.

STATE

The State setting determines whether the port is active or inactive. An inactive port does not occupy a time slot on a WAN link. Set the state setting to **stdby** (standby) for ports that are not to be used or that are not yet configured. Set it to **actv** (active) for ports that are ready for use.

WAN/SRV

The WAN/SRV setting identifies the card to which the output of this port is directed. If **wan** is chosen, the data from this port will be directed to a WAN port (the options are **w1-1** to **w4-2**). If **serv** is chosen, the data will be directed to a port on a Resource card (the options are **P1**, **P2** and **P3**. P1 is FRS in slot P1, P2 is FRS in slot P2 and P3 is FRS in slot P3. After selecting card, select logical port).

The only available rates available when routed to a server are **56K** and **64K**.

TS

The TS setting identifies the time slot on the WAN link to which this port is connected. Values range from **01** to **24** for T1 links and **01** to **31** (excluding TS 16 in **cas** or **ccs** mode) for E1 links. For a display of the available time slots, refer to the cross-connect map for the WAN link.

FRAME

The Frame setting allows you to define the framing of the time slot connected to the OCU-DP port. The options are **a** (DS0A), **b-5** (DS0B) with a limit of five ports, **b-10** (DS0B) with a limit of 10 ports, and **b-20** (DS0B) with a limit of 20 ports, as shown in Figure 17-25.

RATE

The Rate setting identifies the highest data transmission rate for the current port. Values are **2.4**, **4.8**, **9.6**, **19.2**, **56k**, **64k**, and **sw56k** (Switched 56 kbps). Figure 17-2 shows the various rates. When the WAN/SRV option is set to **P1**, **P2**, or **P3** (Four Server cards), the only valid options for RATE are **56K** and **64K**.

SR TS

The Sub-Rate Time Slot (SR TS) indicates the subrate position within the DS0 time slot the port will occupy (see Figure 17-3). If **a** framing is selected, only one subrate time slot is supported and the SR TS setting will default to **1**. If **b-5** framing is selected, the subrate time slots available are **1** to **5**. If **b-10** framing is selected, the subrate time slots available are **1** to **10**. If **b-20** framing is selected, the subrate time slots available are **1** to **20**.

In **b-5** framing, if circuits with speeds greater than 9.6 kbps are assigned to the subrate time slot, adjacent subrate time slots must be available to accommodate their size. A 19.2 kbps circuit would occupy two contiguous subrate time slots. This leaves space for up to three 9.6 kbps circuits from other OCU-DP cards and ports.

The SR TS number selected will be the first segment occupied by this circuit. If a 19.2 kbps circuit occupies two segments of the **b-5** frame, selecting SR TS 1 will assign it to segments 1 and 2. Segments 3, 4 and 5 may be assigned independently to 9.6 kbps (or less) circuits from other OCU-DP cards.

If a circuit is assigned that exceeds the slots necessary to accommodate it, such as a 19.2 kbps circuit to SR TS 5 in **b-5** framing, the message "Invalid SR TS" will be displayed. If a circuit requires more space than the SR TS has available, such as a having a 19.2 kbps circuit assigned to SR TS 1, a 19.2 kbps circuit assigned to SR TS 3 and then attempting to assign a 19.2 kbps circuit to SR TS 4, the message "SR TS overlapping" will be displayed.

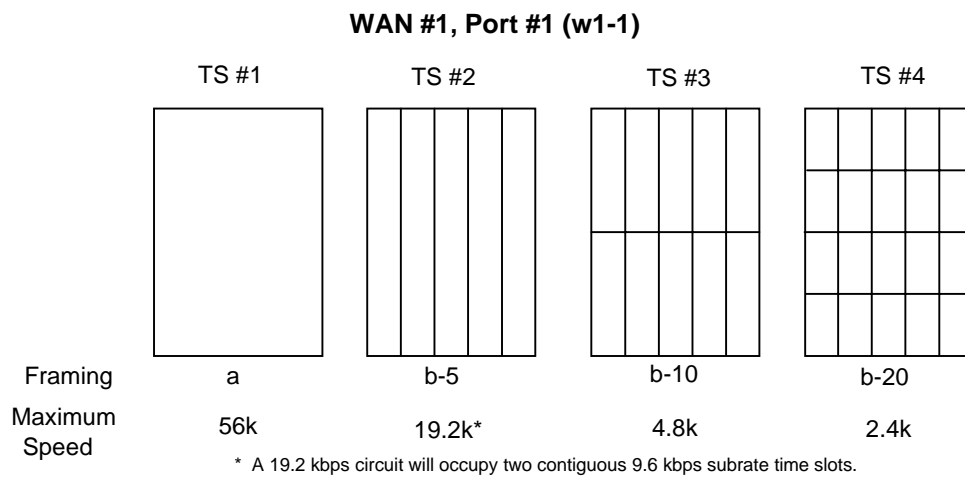

Figure 17-2. Data Frames, Rates, and Time Slot Assignments

MODE

The Mode setting options are **ocu** and **csu**. You should select **ocu** whenever the OCU-DP port is attached to a DSU/CSU over a 4-wire circuit. In that mode, the OCU-DP port will generate the necessary sealing current and the DSU/CSU will terminate it. The **csu** mode should not be used unless you have two back-to-back OCU-DP ports. In that case, to achieve proper orientation and sealing current, configure one of two OCU-DP ports for the **ocu** mode and the other for the **csu** mode. The **csu** mode is not supported on the OCU-DP 5 Card, which has five or ten ports.

ERR COR

The Error Correction setting is used only on the OCU-DP 2 Card. It provides different methods of error correction, depending on the data Rate selected. The default ERR COR setting is **off**. If you choose subrate speeds of **9.6k** or less in the Rate setting, the Error Correction option **maj-v** (majority voting) is available. Using majority-vote error correction allows the system to poll the data for errors and decide on the correct data based on the repeated bit pattern.

The **bch** error correction option is available for **19.2K** only. **Bch** Error Correction is not supported on the OCU-DP5 or OCU-DP 10 Card. **Maj-v** is supported for **2.4, 4.8, and 9.6K**.

SECOND

Secondary channel operation allows the DSU/CSU to establish a separate lower-speed data circuit with the OCU-DP port. When synchronized, this special circuit can be used for testing and maintenance of the main circuit, or for transmission of other low-speed data. The settings are **on** and **off**.

The secondary channel is transported in the 8th bit position of the DS0 time slot to which the OCU-DP is assigned. Table 17-3 shows the secondary channel rate associated with the various primary port rates supported by the card. For a further description of the secondary channel function, refer to Pub 62310 and TA-TSY 000077 and TA-TSY 000083.

Table 17-3. OCU-DP Primary and Secondary Channel Rates

Primary Port Rate	Secondary Channel Rate
56 kbps	2666 bps
19.2 kbps	1,066 bps
9.6 kbps	533 bps
4.8 kbps	266 bps
2.4 kbps	133 bps

USER LB

The User Loopback (USER LB) is a specialized code conversion function that is only relevant in Taiwan and some other countries in the Far East. The options are **d** and **o**, neither of which has any effect in North America.

LB

The OCU-DP card supports three Loopback options that test on the card itself. The **dte** option loops the 4-wire analog interface of the OCU-DP port towards the attached CSU/DSU. It is used to test the local cabling and the analog drivers in the OCU-DP card (see Figure 17-36).

The **net-a** (Network A) option loops the 4-wire OCU-DP interface towards the network. Use it to test all of the OCU-DP card circuitry, the system common equipment, the WAN link card, the remote equipment and the WAN line between the two sites (see Figure 17-47).



Note: *There are various types of test sets that can be used to generate loopbacks in the field. When a test set is initiated for an OCU-DP card an “l” status should be present on the port of the OCU-DP to indicate a loopback. If not, simply perform a “refresh” operation to update the screen.*

The **net-d** (Network D) option puts a loopback towards the network at the point where the OCU-DP card interfaces with the system bus. It separates the OCU-DP card circuitry from the system common equipment, WAN card, remote equipment, and WAN line between the two sites (see Figure 17-58).

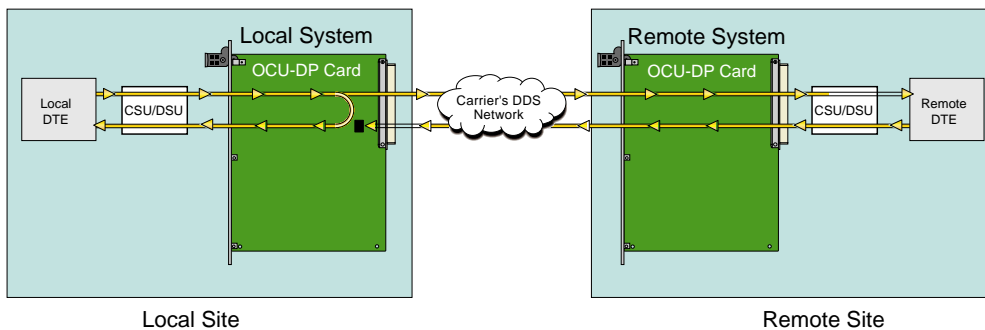

Figure 17-3.OCU Local Loopback (dte option)

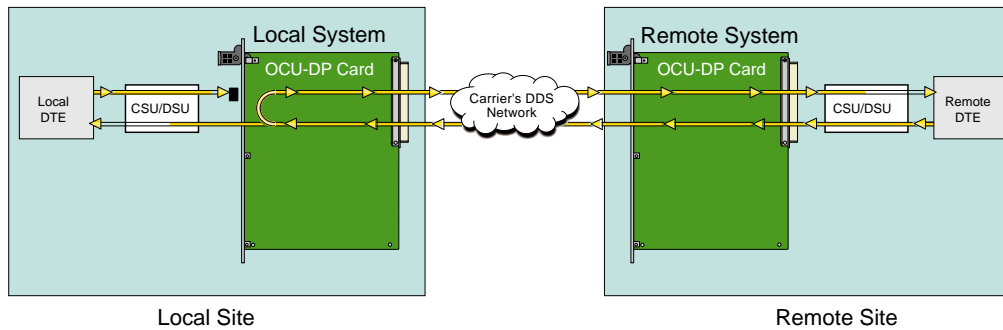

Figure 17-4.OCU Local Loopback (net-a option)

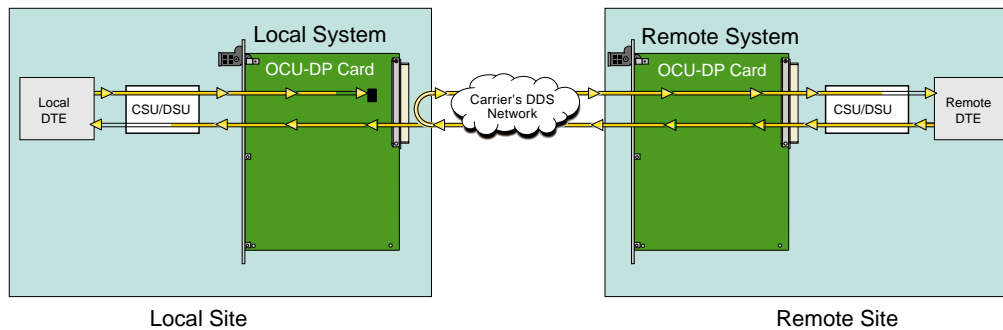

Figure 17-5.OCU Local Loopback (net-d option)

LB GEN

The Loopback Generate settings initiate various in-band diagnostic codes sent to the remote equipment. These codes are compatible with DDS networks and allow users to command a latching loopback at remote DDS equipment. The **ds0-n** loopback loops the analog interface of the remote OCU-DP device back towards the network for circuits using the 64K Rate. The **ocu-n** loopback loops the analog interface of the remote OCU-DP device back towards the network for circuits using the 56K or less Rates. The **csu-n** loopback loops the 4-wire interface of the remote CSU/DSU device back towards the network. **A 48V converter is required for this loopback.**

The **csu-u** loopback loops the 4-wire interface of the local CSU/DSU device towards the network. Figure 17-6 through Figure 17-8 show the loopback locations. You can also turn all remote loopbacks **off**.

Loop-up or loop-down commands cannot be implemented for two ports on the same card simultaneously. You must finish all loopback operations on one port before trying to perform any loopbacks on another port.

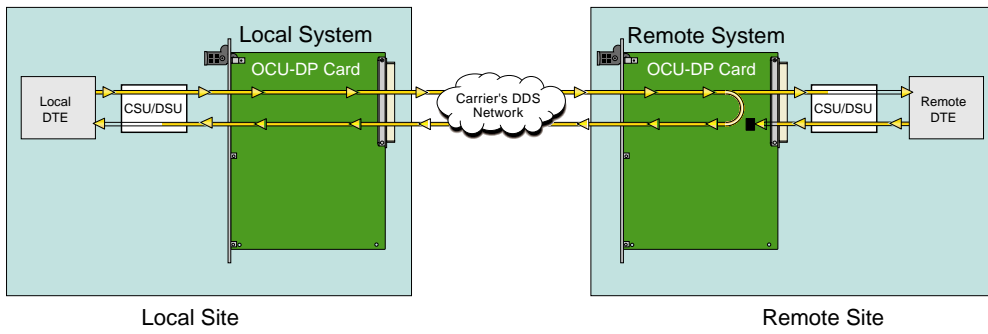

Figure 17-6.OCU Remote Loopback (ds0-n and ocu-n options)

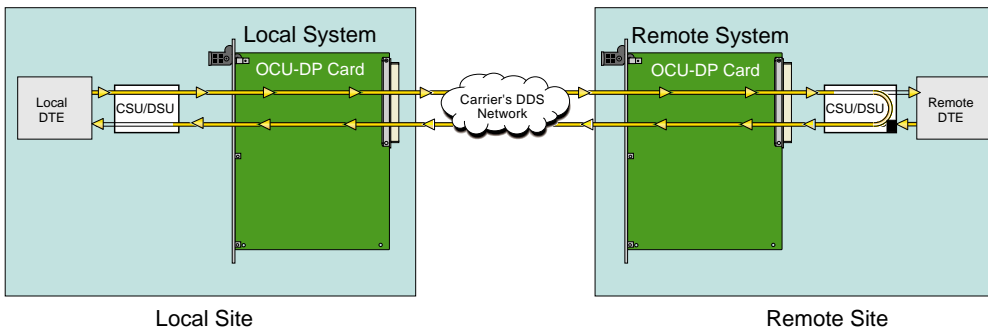

Figure 17-7.OCU Remote Loopback (csu-n option)

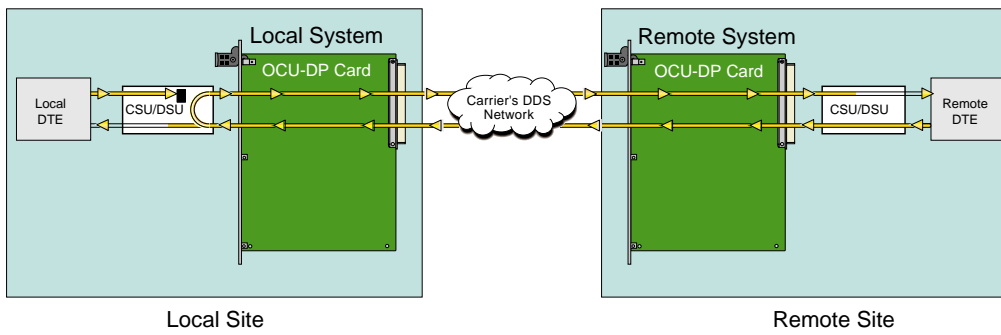

Figure 17-8.OCU Remote Loopback (csu-u option)

LB DET

The Loopback Detection setting determines how the system responds to latching loopback commands from remote equipment. The OCU-DP reacts only to the in-band DDS format loopback commands for Channel Loop, OCU Loop and DSU Loop. The Loopback Detection setting does not affect local loopback commands from the local control terminal. The settings are **off**, **on** and **w/to** (on with time out).

The **off** option causes the system to ignore all remote loopback commands. The **on** option causes the system to monitor for DDS format loopback commands from the remote equipment. If the system detects a loopback command, it loops the data back until the remote equipment sends a stop loopback command. The time-out (**w/to**) option is the same as the **on** option, except that after 10 minutes the system automatically releases loopbacks commanded by the remote equipment.

When using the OCU-DP port for a clear-channel, 64 kbps circuit in DS0A mode, you should set the loopback detection to **off** to prevent unintentional loopback activation.

There are four sequences required for loopback. Each sequence is a given byte that is repeated several times. In-between the sequences there is some allowance for stray bytes but only related bytes. If enough illegal bytes are detected before the proper ones, then any progress toward loopback is lost. The probability calculation with the following assumptions is: (a) the rate is 64K (any other rate is less likely since bit 8 is restricted); (b) proper bytes and illegal bytes come in randomly but the proper bytes are 10 times more likely than standard gaussian data. The false detect probability is $6 \text{ E-}18$ or about 600,000 years average between false loopbacks.

17.3.2 Performance Data Screen

If "majority vote" or "BCH" error correction is enabled on the OCU-DP 2 Card, the system will support performance monitoring of data traffic. The Performance Data Screen is accessed by selecting one of the two ports from the OCU-DP Card Main Screen and pressing "**p**" (**Perf**). A typical Performance Data Screen is shown in Figure 17-92. However, note that error correction and performance data are not supported on the OCU-DP 5 Card.

If the BCH method of error correction is selected, the OCU-DP card will monitor data traffic coming in from the T1 network and use the BCH polynomial values that accompany the data to log the number of errors and to try and correct such errors. Any data errors that are observed are considered "input" data errors and contribute to the input error statistics, including Input Errored Seconds (IES), Input Severely Errored Seconds (ISES), and Input Consecutive Severely Errored Seconds (ICSSES).

Depending on the severity of the input errors, the BCH algorithm may be able to correct the data prior to transmitting it over the four-wire DDS circuit. If an error is so severe that it cannot be corrected, then it will also be logged as an "output" data error and will increment the Output Errored Seconds (OES), Output Severely Errored Seconds (OSES), and Output Consecutive Severely Errored Seconds (OCSES) counters.

If the majority vote method of error correction is selected, the OCU-DP card will monitor data traffic coming in from the T1 network and use the majority-vote algorithm to determine if any data errors have occurred. Any data errors that are observed are considered "input" data errors and contribute to the input error statistics such as Input Errored Seconds (IES), Input Severely Errored Seconds (ISES) and Input Consecutive Severely Errored Seconds (ICSES). Since the majority vote algorithm assumes that it can correct any data input errors, the "output" data error category has no meaning in this context. Consequently, the Output Errored Seconds (OES), Output Severely Errored Seconds (OSES) and Output Consecutive Severely Errored Seconds (OCSES) fields do not apply to the majority vote mode.

Performance data covering the previous twenty-four hours are available and are totaled at the bottom of the screen, as shown in Figure 17-92.

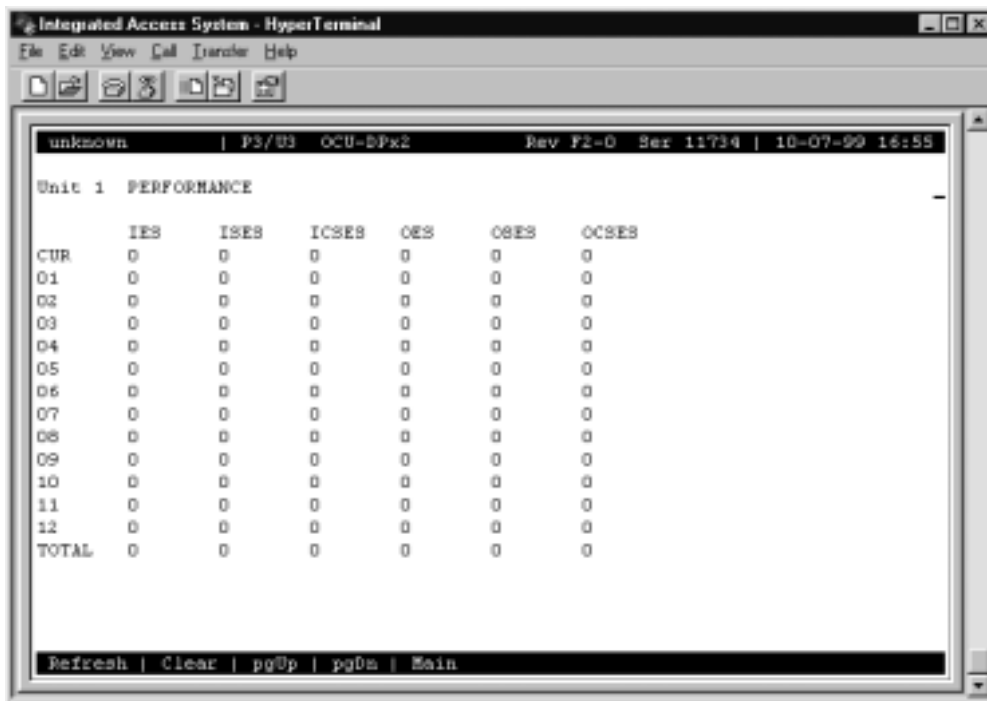

Figure 17-9. Typical Performance Data Screen

Table 17-4 lists the actions you can perform from the above screen by pressing the keys corresponding to the uppercase letters shown on the bottom highlighted line of the screen.

Table 17-4. Performance Data Screen Actions

Action	Function
Refresh	Updates certain time-related information fields that are not automatically updated (i.e. performance and test data).
Clear	Clears the test screen.
pgUp	Scrolls through data screens from the oldest to the newest.
pgDn	Scrolls through data screens from the newest to the oldest.
Main	Returns to the OCU-DP card main screen.

IES

The Input Errored Seconds (IES) field shows the total number of seconds in which any input errors were detected. Since this is an information-only field, there are no user-selectable parameters.

ISES

The Input Severely Errored Seconds (ISES) field shows the total number of seconds in which the input bit error rate exceeded one bit per thousand (1×10^{-3}). Since this is an information-only field, there are no user-selectable parameters.

ICSES

The Input Consecutive Severely Errored Seconds (ICSES) field is triggered by the occurrence of ten consecutive Input Severely Errored Seconds. Once triggered, the ICSES field will increment (by one) for each elapsed second until the system logs ten consecutive seconds that are not severely errored. Since this is an information-only field, there are no user-selectable parameters.

OES

The Output Errored Seconds (OES) field shows the total number of seconds in which any output errors were detected. This field only applies if the error correction method selected is BCH. Since this is an information-only field, there are no user-selectable parameters.

OSES

The Output Severely Errored Seconds (OSES) field shows the total number of seconds in which the output bit error rate exceeded one bit per thousand (1×10^{-3}). This field only applies if the error correction method selected is BCH. Since this is an information-only field, there are no user-selectable parameters.

OCSES

The Output Consecutive Severely Errored Seconds (OCSES) field is triggered by the occurrence of ten consecutive Output Severely Errored Seconds. Once triggered, the OCSES field will increment by one for each elapsed second until the system logs ten consecutive that are not severely errored. This field only applies if the error correction method selected is BCH. Since this is an information-only field, there are no user-selectable parameters.

17.3.3 Test Screen

Pressing “t” (**Test**) in the OCU-DP Card Main Screen will bring up the Test Screen shown in Figure 17-104. From this screen, you can create test situations between OCU-DP cards, or between a single OCU-DP card and data test equipment at a remote site.

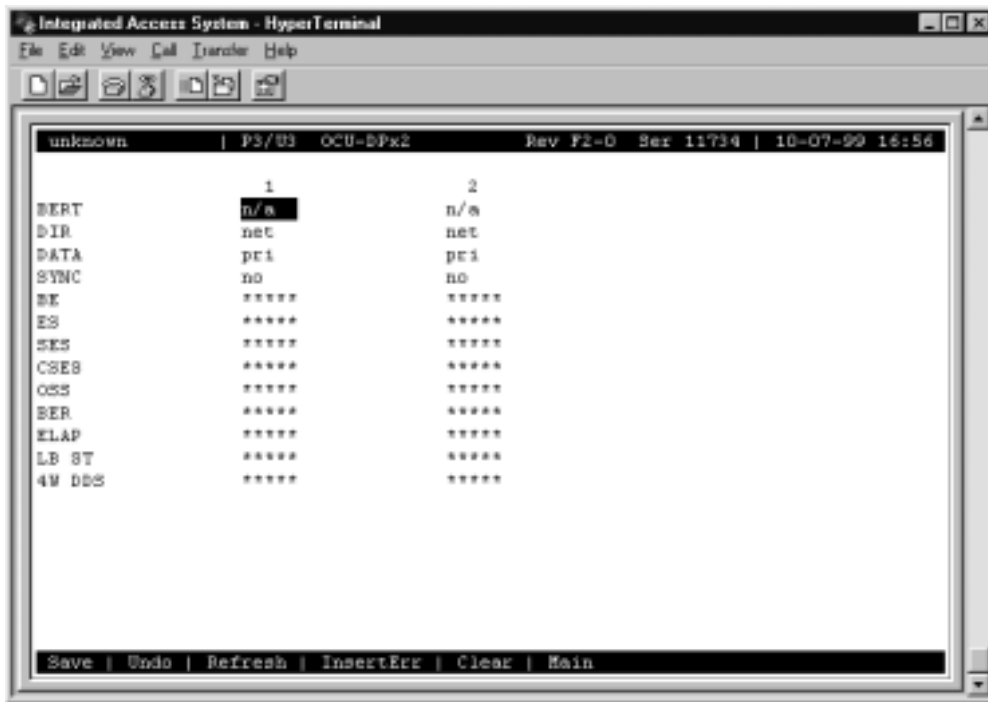

Figure 17-10. Typical OCU-DP Card Test Screen

Table 17-5 lists the actions you can perform from the Test Screen. These appear on the bottom highlighted line of the screen. Table 17-6 lists the settings controlled on this screen along with their possible and default values.

Table 17-5. Test Screen Actions

Action	Function
Save	Saves changes to settings.
Undo	Returns all settings to the last saved state.
Refresh	Since the data in this screen is not updated in real time, the Refresh command is used to obtain the latest statistics.
insertErr	Allows you to manually insert a single error into a clear data signal.
Test	Clears the Test Screen.
Main	Returns to the OCU-DP Card Main Screen. If changes are made to settings and not saved, you will be prompted to save or lose changes.

Table 17-6. Test Screen Option Settings and Defaults

Parameter	User Options	Default
BERT	off mark space 1:1 1:7 511 2047 qrss	off
DIR	net user	net
DATA	pri sec	pri
SYNC	information only—no user options	
BE	information only—no user options	
ES	information only—no user options	
SES	information only—no user options	
CSES	information only—no user options	
OSS	information only—no user options	
BER	information only—no user options	
ELAP	information only—no user options	
LB ST	information only—no user options	
4W DDS	information only—no user options	

BERT

The Bit Error Rate Tester (BERT) sends a data pattern and measures the bit error rate (BER) on the selected OCU-DP port. The patterns that can be selected are **off**, **mark** (all ones), **space** (all zeros), **1:1** (1010), **1:7** (0100-0000), **511** (511 test pattern), **2047** (2047 test pattern) and **qrss** (quasi-random pseudo signal).

DIR

The Direction (DIR) setting allows users to specify where the BERT test signal should be directed. The **net** (network) option transmits the test signal toward the Wide Area Network (WAN). The **user** option directs the signal toward the attached CSU/DSU device over the 4-wire interface.

DATA

The DATA setting specifies whether the BERT test signal should be connected to the **pri** (Primary) or the **sec** (Secondary) channel of the OCU-DP port. If there is no Secondary channel associated with the OCU-DP port, the only option available is **pri**.

SYNC

The Synchronization (SYNC) field shows if the integrated BERT has achieved synchronization either with itself via a remote loopback or with the remote test equipment. Since this is an information-only field, there are no user-selectable parameters.

BE

The Bit Error (BE) field shows the total number of bit errors logged. Since this is an information-only field, there are no user-selectable parameters.

ES

The Errored Seconds (ES) field shows the total number of seconds in which any errors were detected. Since this is an information-only field, there are no user-selectable parameters.

SES

The Severely Errored Seconds (SES) field shows the total number of seconds in which the bit error rate exceeded one bit per thousand (1×10^{-3}). Since this is an information-only field, there are no user-selectable parameters.

CSES

The Consecutive Severely Errored Seconds (CSES) field is triggered by the occurrence of ten consecutive Severely Errored Seconds. Once triggered, the CSES field will increment (by one) for each elapsed second until the system logs ten consecutive non-Severely Errored Seconds. Since this is an information-only field, there are no user-selectable parameters.

OSS

The Out of Synchronization Seconds (OSS) field shows the number of seconds that the OCU-DP BERT has been out of synchronization. Since this is an information-only field, there are no user-selectable parameters.

BER

The Bit Error Rate (BER) field shows the rate at which errors are being logged. The system calculates BER by dividing the number of bit errors (BE) by the total number of bits transmitted during the test. Since this is an information-only field, there are no user-selectable parameters.

ELAP

The Elapsed time setting shows the running tally of the total number of seconds during the test. Since this is an information-only field, there are no user-selectable parameters.

LB ST

The Loopback State (LB STATE) field indicates the local loopback selected on the main screen for this port. This field will show **off**, **ta**, or **net**. Since this is an information-only field, there are no user-selectable parameters.

4W DDS

The 4-wire DDS setting shows if the 4-wire interface is both present and operational. The field will show **norm** if the interface is connected or **nos** for No Signal. Since this is an information-only field, there are no user-selectable parameters.

17.4 OCU-DP Card Error Messages

Refer to Appendix B in the System Reference Guide for further information on Error Messages regarding this card.

17.5 OCU-DP Card Troubleshooting

OCU-DP card problems could indicate a number of possible causes, including:

- Faulty receiving DTE at the near end (where the problem was first noticed)
- Faulty transmitting DTE at the far (opposite) end
- Faulty cabling between the DSU/CSU and OCU-DP card at the near end
- Faulty cabling between the DSU/CSU and OCU-DP at the far end
- T1 or E1 network failure
- Improper card configuration at either end (e.g., time slot and/or WAN port assignments)

Typically, a problem is indicated by a loss of incoming signal on a data port at either end of the circuit. You can perform numerous tasks to isolate the trouble and clear it. When troubleshooting transmission problems on a data circuit passing through an OCU-DP card, follow this general sequence:

1. First, verify that the T1 or E1 network is working properly by checking for current CGA-Red and CGA-Yellow alarms. If the network is faulty, the same transmission problem may exist with the other ports of the same OCU-DP card, and also with the data ports of all other data cards connected to the same T1 or E1 line. If no CGA alarms are present, continue with step 3.
3. Verify that the DS0 time slot and sub-rate TS assignments of the faulty port at both ends of the data circuit path are correct. Also be sure the port is connected to the proper WAN card and port and that other critical parameters, such as **RATE**, are set the same at each end. If these assignments are correct, continue with step 4.
4. At the local end (where the incoming data loss was first observed), use the loopback and test signal functions of the OCU-DP card to test the affected port. These tests are accessible from the OCU-DP Card Main Screen (through the **LB** and related parameters) and its associated Test Screen (through the **BERT** parameter), as previously described in this chapter. They allow you to test the circuit path in segments and thereby quickly pinpoint the problem.
5. If necessary, also perform loopbacks and send test signals to the affected circuit from the other end. In addition, you can perform end-to-end tests using a suitable data test set at one or both ends of the circuit in conjunction with the loopback functions of the OCU-DP card at either end.
6. If the OCUDP card is determined to be faulty, replace it and return the faulty unit for repair to the location specified by your distributor.

17.6 OCU-DP Card Specifications

OCU-DP Card 8249													
Number of Ports - 2	Connector - female 8-pin RJ-48												
OCU-DP Card 824160													
Number of Ports - 5	Connector - female 8-pin RJ-48												
OCU-DP Card 824660													
Number of Ports - 10	Connector - female 8-pin RJ-48												
OCU-DP 824x Card Specifications													
Data Format	Synchronous-binary, serial												
Data Encoding	Bipolar, return to 0, AMI												
Line Interface	4-wire												
Speeds	2.4, 4.8, 9.6, 19.2, 56 and 64 kbps												
Sub-rate Framing Formatting	DS0-A, DS0-B with 5, 10, or 20 divisions per DS0												
Error Correction	Majority vote for speeds 9.6 kbps or less (All Cards) BCH for 19.2, 56, 64 kbps (Model 8249 Only)												
Secondary Channel	As described in AT&T 62310, 62411 Addendum (pass through only) and TA TSY 000077 and TA TSY 000083, a separate lower speed data circuit which may be used for testing and maintenance. Modes are on or off. Secondary Speeds Supported are:												
	<table border="1"> <thead> <tr> <th>Primary Port Rate</th> <th>Secondary Port Rate</th> </tr> </thead> <tbody> <tr> <td>56 kbps</td> <td>2,666 bps</td> </tr> <tr> <td>19.2 kbps</td> <td>1,066 bps</td> </tr> <tr> <td>9.6 kbps</td> <td>533 bps</td> </tr> <tr> <td>4.8 kbps</td> <td>266 bps</td> </tr> <tr> <td>2.4 kbps</td> <td>133 bps</td> </tr> </tbody> </table>	Primary Port Rate	Secondary Port Rate	56 kbps	2,666 bps	19.2 kbps	1,066 bps	9.6 kbps	533 bps	4.8 kbps	266 bps	2.4 kbps	133 bps
Primary Port Rate	Secondary Port Rate												
56 kbps	2,666 bps												
19.2 kbps	1,066 bps												
9.6 kbps	533 bps												
4.8 kbps	266 bps												
2.4 kbps	133 bps												
Operational Modes	OCU or CSU (software selectable per line)												
Loopbacks	Off, DTE, Net-a, Net-d (software selectable) (Net-a loops 4-wire interface to the network, Net-d loops to the network at card interface to system bus)												
Loopback Generation (Latching only)	Various loopbacks sent in-band to remote equipment: Off, DS0-n (loops the analog interface of the remote for 56K or less rate), CSU-N (loops the 4-wire interface of the remote), CSU-N (loops the 4-wire interface of local device).												
Loopback Detection	Off, On, On with 10 minute time-out (Latching and Non-Latching)												

Distances Supported

Primary Rate	Secondary Rate	Line Rate	Loss Limit dB	19 Ga. (KF)	22 Ga. (KF)	24 Ga. (KF)	26 Ga. (KF)
2400	---	2400	34	133.0	90.7	71.5	56.8
2400	133	3200	34	114.3	79.1	61.9	48.7
4800	---	4800	34	97.6	65.8	51.1	40.2
4800	267	6400	34	86.3	57.5	44.8	35.1
9600	---	9600	34	74.2	48.3	37.1	28.4
9600	533	12800	34	67.5	42.9	32.8	25.2
19200	---	19200	34	60.0	36.9	27.6	21.0
19200	1067	25600	34	57.0	33.9	25.1	19.9
56000	---	56000	43	60.7	35.0	24.5	17.6
56000	2667	72000	43	57.6	33.3	23.1	16.5
64000	---	72000	43	57.6	33.3	23.1	16.5

Standards Compatibility

AT&T	TR 62411 Pub 62310	Accunet T1.5 Service, Description and Interface Specifications DS0 Digital Local Channel Description and Interface Specification, August 1993
Bellcore	TA-TSY-000077 TA-TSY-000083	Digital Channel Banks - Requirements for Data port Channel Unit Functions, Issue 3, April 1986 Generic Requirements for the Digital Data System (DDS) Network Office Channel Unit, Issue 2, April 1986
ANSI	T1.107-1988	Digital Hierarchy - Format Specifications 1988

Chapter 18

DS0-DP Card

18.1 Introduction

This chapter provides installation, configuration, and troubleshooting information for the DS0 Dataport (DS0-DP) Card. This card is labeled as the DS0-DP 4 card on its faceplate ejector.

18.2 DS0-DP Card Description

18.2.1 DS0-DP 4 Card Description (825460)

The DS0-DP 4 Card Contradirectional/Codirectional Data Unit (DS0-DP/G.703) provides a 64 kbps interface to a DS0 time slot of a T1 or E1 network. Since the byte alignment of the 64 kbps data stream to the time slot is essential, the interface provides a 64 kbps bit clock and an 8 kHz byte clock in the DS0-DP mode.

Notice!

UL STATEMENT

OPERATION OF THIS INTERFACE IS LIMITED TO INTRA-BUILDING CONNECTIONS ONLY

18.2.1.1 Card Jumper/Switch Settings

The DS0-DP 4 Card does not have any jumpers or switches on its mainboard.

18.2.1.2 Installing the Card

Install the DS0-DP 4 Card into any user card slot. These slots are U1 to U8 on the two-sided chassis and front-loading chassis with power supplies on top, and P1 to P4 or W1 to W4 on the front-loading chassis with power supplies on the side.

18.3 DS0-DP Card User Screens and Settings

18.3.1 DS0-DP Card Main Screen

You must configure the DS0-DP card for operation. This is done from the DS0-DP Card Main Screen, which is shown in Figure 18-1. To go to that screen, highlight the desired card in the System Main Screen and press <Enter>.

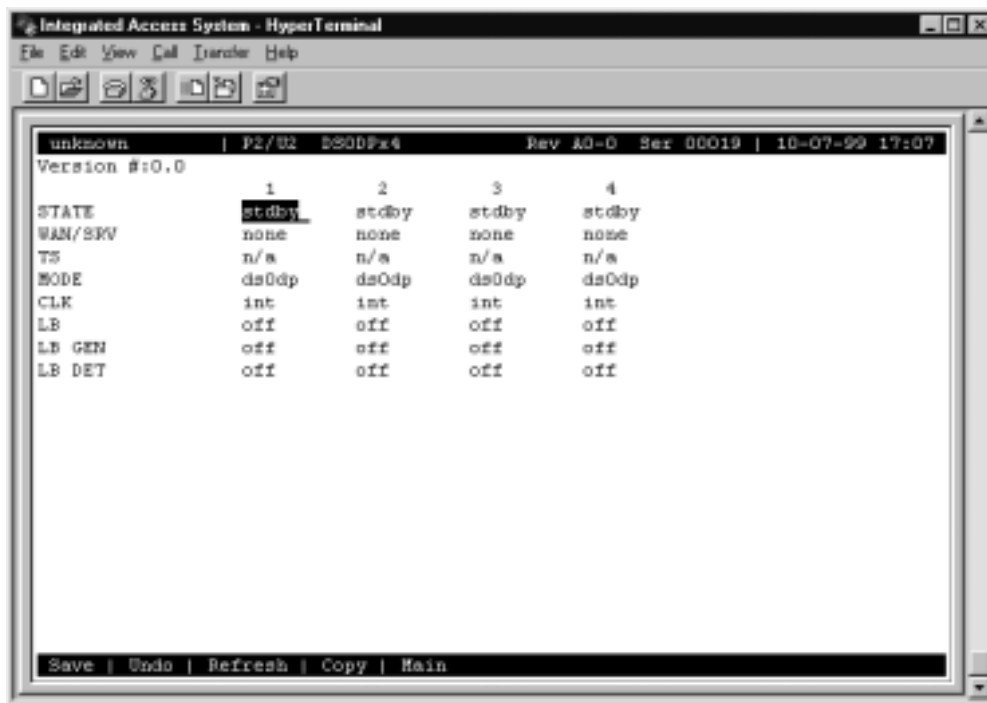

Figure 18-1. Typical DS0-DP Card Main Screen

The bottom highlighted line of this screen shows several actions you can perform from the screen. To perform an action, simply press the key indicated by the uppercase letter of the desired action. For example, to save your configuration settings, press “s”. Table 18-1 lists these actions, and Table 18-2 summarizes the DS0-DP card parameters and available settings. These are also described in the following paragraphs.

Table 18-1. Main Screen Actions

Action	Function
Save	Saves changes to settings.
Undo	Returns all settings to the last saved state.
Refresh	Redraws the Main Screen.
Copy	Copies the contents of the current column to the next column. Useful if you change a lot of entries in one column and want to repeat those changes in subsequent columns.
Main	Returns to the System Main Screen. If changes are made to settings and not saved, you will be prompted to save or lose changes.

Table 18-2. Main Screen Option Settings and Defaults

Parameter	User Options	Default
STATE	stdby actv	stdby
WAN/SRV	none wan	none
TS	n/a 01-24 01-31	n/a
MODE	ds0dp contr codir	ds0dp
CLK	int ext n/a	int
LB	off dte net	off
LB GEN	off ocu dsu csu ds0	off
LB DET	off enab w/to	off

STATE

The State setting determines whether the port is active or inactive. An inactive port does not occupy a time slot on a WAN link. Set the state setting to **stdby** (standby) for ports that are not to be used or are not yet configured. Set it to **actv** (active) for ports that are ready for use.

WAN/SRV

The WAN/SRV setting identifies the card to which the output of this port is directed. If **wan** is chosen, the data from this port will be directed to a WAN port (the options are **w1-1** to **w4-2**). You then need to select a time slot.

The WAN setting identifies the WAN link assigned to this port. It is not necessary for all ports on the same card to be assigned to the same WAN link, or to contiguous time slots on a WAN link. Ports can be split between WAN and Server card links.

TS

If the WAN/SRV parameter is **none**, the TS parameter will always be **n/a**. If the WAN/SRV parameter is **wan** (or a WAN port) then TS setting identifies the time slot on the WAN link to which this port is assigned. Values range from **1** to **24** for T1 links and **1** to **31** (excluding time slot 16 in **cas** or **ccs** mode) for E1 links.

MODE

This option displays the selection of modes. In **ds0dp** mode, the port will provide a common bit and byte clock to be used by the attached DTE device for both receive and transmit. When one port is set to **ds0dp** all other ports will default to the DS0-DP mode as well. Similarly, when one port is changed to one of the G.703 modes (Codirectional or Contra directional), any port set for the DS0-DP mode will default to the Contra directional mode. The **contr** selection configures the port for the Contra directional mode. In this mode, the card supplies both the transmit and receive clocks to the DTE. The **codir** selection configures the port for the Codirectional mode. In this mode, the clocks and data make up a composite signal. The clocks must be derived from the data.

CLK

This option allows the selection of the desired clocking mode when in the DS0-DP mode. When set to **int**, the card generates the bit and byte clocks to the DTE. When set to **ext**, the card receives the bit and byte clocks from the attached device. All ports must have the same clock setting, therefore, when one port is changed, all ports are changed. When a G.703 mode is selected, this option defaults to **n/a**. See Table 18-2 for further detail on CLK selection.

LB

This option allows users to set local loopbacks. The **off** option is for no loopbacks. The **dte** selection loops data towards the DTE. The **net** option loops data towards the network.

LB GEN

This option allows users to set local loopbacks. The **off** option is for no loopbacks. The other options are **ocu**, **dsu**, **csu**, **ds0** and force the card to send the appropriate DDS latching loopback code towards the remote end. This option will only function in the DS0-DP mode.

LB DET

This option allows the card to detect DDS latching loopbacks. When set to **off**, no loopbacks can be detected. When set to **enab**, loopbacks will be detected. When a loopback is detected, it will be maintained until a loop down is detected. **w/to** is the same as **enab** except that if no loop down is detected after 10 minutes, the loopback will self-terminate. This option only functions in the DS0-DP mode.

18.4 DS0-DP Card Error Messages

Refer to Appendix B in the System Reference Guide for further information on Error Messages regarding this card.

18.5 DS0-DP Card Troubleshooting

Problems with a DS0-DP card could indicate a number of causes. Some possibilities are:

- Faulty receiving DTE at the near end (where the problem was first noticed)
- Faulty transmitting DTE at the far (opposite) end
- Faulty cabling between the DTE and DS0-DP card at the near end
- Faulty cabling between the DTE and DS0-DP card at the far end
- T1 or E1 network failure
- Improper card configuration at either end (e.g., time slot and/or WAN port assignments)

Typically, a problem is indicated by a loss of incoming signal on a data port at either end of the circuit. You can perform numerous tasks to isolate the trouble and clear it. When troubleshooting transmission problems on a data circuit passing through a DS0-DP card, follow this general sequence:

1. If all ports are affected, verify that the US/EUR jumper is correctly placed to match the US/EUR jumper on the chassis.
2. Verify that the T1 or E1 network is working properly by checking for current CGA-Red and CGA-Yellow alarms. If the network is faulty, the same transmission problem may exist with the other ports of the same DS0-DP card, and also with the data ports of all other data cards connected to the same T1 or E1 line. If no CGA alarms are present, continue with step 3.
3. Verify that the DS0 time slot assignments of the faulty port at both ends of the data circuit path are correct. Also be sure the port is connected to the proper WAN card and port at each end. If these assignments are correct, continue with step 4.
4. At the local end (where the incoming data loss was first observed), use the loopback functions of the DS0-DP card to test the affected port. These tests are accessible from the DS0-DP Card Main Screen, as previously described in this chapter. They allow you to test the circuit path in segments and thereby quickly pinpoint the problem.
5. If necessary, also perform loopbacks and send test signals to the affected circuit from the other end. In addition, you can perform end-to-end tests using a suitable data test set at one or both ends of the circuit in conjunction with the loopback functions of the DS0-DP card at either end.
6. If the DS0-DP card is determined to be faulty, replace it and return the faulty unit for repair to the location specified by your distributor.

18.6 DS0-DP Card Specifications

DS0-DO Card (825460)

Data Rate	64 Kbps
Interface Connector	DB15 Receptacle

Electrical Interface

DS0-DP	$\pm 5.0V$, 135 Ohms
G.703	$\pm 1.0V$, 120 Ohms

Control

Configuration	Control via local terminal or remote NMS
---------------	---

Dimensions

Height	8" (20.32 cm)
Width	6.75" (17.15 cm)

Operating Environment

Ambient	0 to 50 ° C
Storage	-40 to 70 ° C
Relative Humidity	Maximum 95% non-condensing @ 40 degrees ° C
Altitude	Up to 10,000 Ft. AMSL

Chapter 19

Server Cards

ADPCM Card

19.1 Introduction

This chapter provides installation, configuration, and troubleshooting information for the Adaptive Differential Pulse-Code Modulation (ADPCM) Card. This card is labeled as the ADPCM 64 card on its faceplate ejector.

19.2 ADPCM Card Descriptions

19.2.1 ADPCM 64 Card Description (887170)

The ADPCM 64 Card has 32 pairs of voice compression engines that accept inputs directly from voice, SRU, and/or BRI data cards in the same system unit, or voice traffic from WAN links through the system. This card requires a matching card at the other end to decompress the voice channels to normal 64 kbps operation.

With previous versions of the IMACS, signaling conversion was only supported for voice ports when routed over the WAN and not when routed through an ADPCM card. With version 5.3.1 and higher of the IMACS host CPU firmware, signaling conversion is also supported for voice channels routed through the ADPCM. The conversion table is the same as for passing the channel through a WAN, and available from the interface card's main screen by selecting "taBs". Signaling conversion is enabled / disabled using the same SIG CONV parameter as used for conversion over a WAN. This field is found on Figure 19-1, the E & M Voice Card's main screen.

Each pair of compression engines uses one 64 kbps DS0 time slot for two compressed voice channels. Each engine can compress 64 kbps voice traffic into 24 kbps, 32 kbps, or 40 kbps, depending on the voice signal quality required.

The rate of a DS0 time slot is 64 kbps, so the sum of the compression rates for engines 1 and 2 must equal 64 kbps. For example, if you assign a 32 kbps circuit to engine 1, engine 2 can only accept another 32 kbps circuit. Also, a 40 kbps circuit can only be paired with a 24 kbps circuit, and vice versa.

The ADPCM compression engines always work in pairs. Engines 1 and 2, 3 and 4, 5 and 6, and 7 and 8 are paired. Each member of the pair must have the same ADPCM WAN port and ADPCM time slot. **Also, both members of the compression engine pair must be active before either port will operate.**

The ADPCM 64 Card can transport low-speed asynchronous data transmission (19.2 kbps or less) from an SRU user card port that will occupy a 24 kbps engine. Each data circuit must be paired with a 40 kbps voice channel. The card can also compress B-channel voice traffic from a BRI card without restricting compression rates.

The Integrated Access System can have up to three ADPCM 64 Cards (two normal cards and an identical redundant card).

The ADPCM 64 Card supports Transition Signaling as defined in ANSI T1.302-1989, with the exception of the Alarm bits. ANSI T1.302 specifies signaling at the 32 bps compression rate. The card uses this scheme for 24 bps and 40 bps, even though those rates are not included in the standard. Table 19-1 summarizes the signals supported by each transcoder data rate. Your DS0 time slot configuration must adhere to these specifications.

Table 19-1. ADPCM Compression Rates

Transcoder Rate	Voice Quality (MOS)*	Modem Data	DTMF	FAX
24 kbps	3.6-3.8 Range	no	nounder study	no
32 kbps	4.0-4.3 Range	up to 4.8 kbps V.32 9.6 kbps	OK	Group II
40 kbps	4.0-4.3 Range	up to 12 kbps V.32 14.4 (no/yes/tbd)	OK	Group III

* MOS = Mean Opinion Score based on subjective evaluation

19.2.1.1 Card Jumper/Switch Settings

The ADPCM 64 Card does not have any jumpers or switches on its motherboard.

19.2.1.2 Installing the ADPCM Card

Insert the ADPCM card into one of the server card chassis slots (P1 to P3). The system can accommodate up to three server cards.

19.3 ADPCM Card User Screens and Settings

19.3.1 ADPCM Card Main Screen

You must configure the ADPCM card ports for operation. This is done from the ADPCM Card Main Screen, which is shown in Figure 19-1. To go to this screen, highlight the ADPCM card in the System Main Screen and press <Enter>.

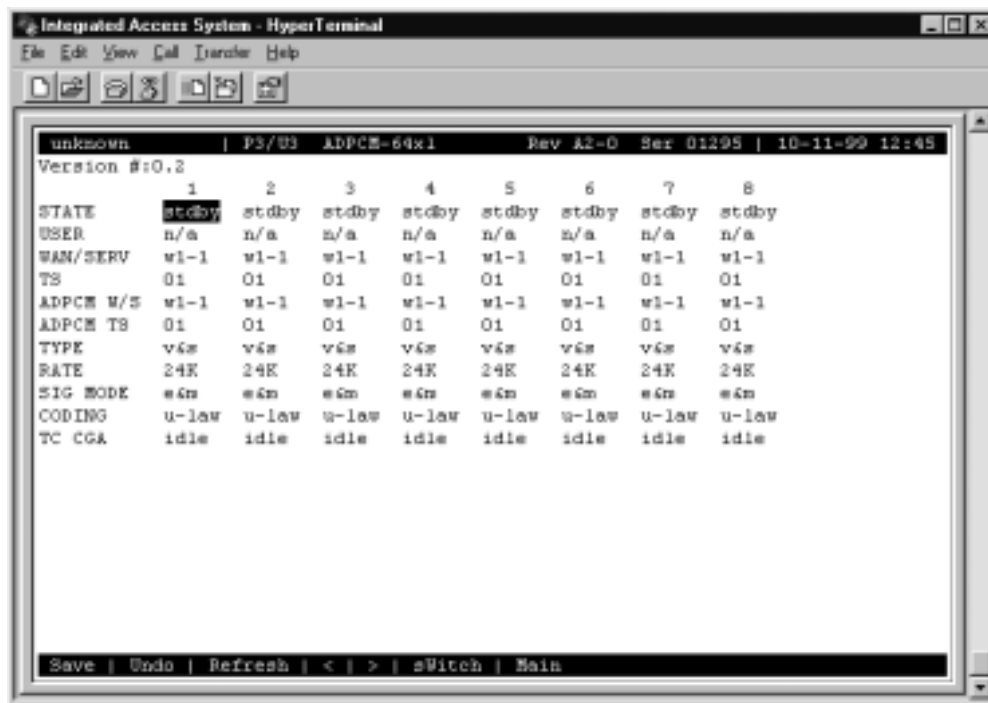

Figure 19-1. Typical ADPCM Card Main Screen

The bottom highlighted line of this screen shows several actions you can perform from the screen. To perform an action, simply press the key indicated by the uppercase letter of the desired action. For example, to save your configuration settings, press “s” to invoke the **Save** command. Table 19-2 lists these actions.

Table 19-2. ADPCM Card Main Screen Actions

Action	Function
Save	Saves changes to settings.
Undo	Returns all settings to the last saved state.
Refresh	Redraws the current screen with the latest information.
pg_Left	Pages through the 64 engines (highest to lowest), 8 at a time.
pg_righT	Pages through the 64 engines (lowest to highest), 8 at a time.
SWitch	Switches an active ADPCM card to its redundant mate.
Main	Returns to the ADPCM Card Main Screen. If changes are made to settings and not saved, users will be prompted to save or lose changes.

Table 19-3 summarizes the ADPCM card configuration parameters and available settings. These are also described in the following paragraphs.

Table 19-3. ADPCM Card Setting Options and Defaults

Parameter	User Options	Default
STATE	stdby actv rdnt	stdby
USER	n/a uX-1 through uX-8	n/a
WAN/SERV	n/a w1-1 w1-2 w2-1 w2-2 w3-1 w3-2 w4-1 w4-2	none
TS	n/a 01-24 01-31	01
ADPCM W/S	w1-1 w1-2 w2-1 w2-2 w3-1 w3-2 w4-1 w4-2	none
ADPCM TS	01-24 01-31	01
TYPE	n/a v&s v trnsp	v&s
RATE	n/a 24K 32K 40K	24K
SIG MODE	n/a e&m fxs plar fxo user	e&m
CODING	n/a u-law a-inv	u-law
TC CGA	n/a idle busy	idle

STATE

The State setting determines whether the port is active or inactive. When assigning ADPCM engine pairs for WAN traffic, set the State setting to **stdby** (standby) for ports that are not yet used or not yet configured. Set it to **actv** (active) for ports that are ready for use.

Setting the State to **rdnt** (redundant) for any port on an unused card will cause that card to act as the redundant back-up for all of the other ADPCM cards in that unit. Once a card is designated as a redundant ADPCM card the only way it can be used for regular ADPCM traffic is to change the state of the selected port back to either **actv** or **stdby**.

When assigning ADPCM engine pairs from user cards, changing the port from **stdby** to **actv** and saving the selection information on the user card screen will cause the system to automatically assign an ADPCM engine.

When the engine is assigned from a user card, no changes can be made from the ADPCM card screen to any of the fields.

USER

The User setting identifies the user card and port connected to this engine. This is the place where the ADPCM card will expect incoming (non-compressed) voice, subrate data, and B-channel traffic. If assigned from a voice, SRU, or BRI card port, this selection will show the user card slot and port number (e.g., **u5-2** for the card in slot U5, port 2). If you are assigning a WAN time slot, this setting will show **n/a**.

WAN/SERV

The WAN/SERV setting identifies the incoming WAN link connected to this engine. This is the place where the ADPCM card will expect incoming (non-compressed) voice. If you are assigning voice traffic to a WAN time slot, this setting will show **w1-1** to **w4-2**. If you are assigning to a voice card or SRU card port, this setting will show **n/a**.

TS

The Time slot parameter selects the specific time slot of the above WAN link on which the ADPCM card can expect incoming voice traffic. If WAN 1-1 is equipped with a T1 CSU module or a DSX/CEPT module configured for T1 DSX interface, the options are **1** to **24**. If a DSX/CEPT module is installed on that WAN port and that module is configured for CEPT E1 interface, the options are **1** to **15** and **17** to **31**. If you are assigning time slots to voice or SRU card ports, this setting will be **n/a**.

ADPCM W/S

The ADPCM W/S setting identifies the outgoing WAN link to which the engine is connected. If you are assigning to a voice, SRU, or BRI card port, or to voice traffic from a WAN time slot, this setting will show **w1-1** through **w4-2**. This is the WAN link to which the ADPCM card will send its outgoing (compressed) traffic.

ADPCM TS

The ADPCM Time slot parameter selects the specific time slot on the WAN link chosen in the previous setting that the ADPCM card will send outgoing compressed traffic. The options are determined by the equipment on the WAN link selected in the previous setting. If WAN 1-1 is equipped with an 812 CSU or 811 DSX/CEPT Module configured for DSX, the options are **1** to **24**. If a DSX/CEPT module is installed and configured for CEPT E1, the options are **1** to **15** and **17** to **31**.

TYPE

The Type parameter identifies the voice and signaling requirements for the incoming circuit. The options are **v** (voice), voice and **v&s** (signaling) and **trnsp** (transparent). Use **v** when the input to the ADPCM channel is a 64 kbps channel and inband signaling is not required. Use **v&s** when the input to the ADPCM channel is a 64 kbps voice channel and the ADPCM card must also provide inband signaling.

The **trnsp** setting allows you to map the outputs of SRU ports to the ADPCM channel. The subrate data will be clocked into the ADPCM channel at an input rate of 24 kbps, then passed transparently (non-compressed) through the ADPCM card to the appropriate WAN time slot. This could be useful if you have an odd number of voice channels and want to utilize the empty engine pair of the last ADPCM channel.

The B-channel traffic from the BRI card also uses the **trnsp** setting, but it does not place any restrictions on the compression rates.

If the engine is assigned to a voice card, this selection will show **v&s**. If assigned to an SRU card, it will show **trnsp**. You cannot change it from this screen.

RATE

The Rate parameter identifies the compression requirements for the incoming circuit. The options are **24K**, **32K**, and **40K**. The sum of the pair of engines must always equal 64 kbps.

If this engine is assigned to a user card port, the selection will show the value that was chosen on that port. It cannot be changed from this screen.

SIG MODE

The Signaling Mode parameter identifies the type of signaling required for the incoming circuit from the network. If **v&s** was chosen in the Type setting, the options are **e&m**, **fxs**, **plar**, and **fxo**. If **v** or **trnsp** was chosen in the Type setting, the only option is **n/a**.

If this engine is assigned to a user card, this selection will show **user**. It cannot be changed from this screen.

CODING

The Coding parameter identifies the PCM companding format required for the incoming circuit from the network. The choices are **u-law** or **a-inv**.

If this engine is assigned to a voice or BRI card, this selection will show the value you selected for that port. If this engine is assigned to an SRU card, this selection will show **u-law**. It cannot be changed from this screen.

TC CGA

The Trunk Conditioning CGA setting identifies the type of trunk conditioning required for the incoming circuit. If **v&s** is chosen in the Type setting, the options are **idle** or **busy**. If **trnsp** or **v** is chosen as the Type, the only option is **n/a**.

If this engine is assigned to a voice card, this selection will show the value you selected on the voice card port. If assigned to an SRU or BRI card port, the field will show **n/a**. It cannot be changed from this screen.

19.4 ADPCM Card Error Messages

Refer to Appendix B in the System Reference Guide for further information on Error Messages regarding this card.

19.5 ADPCM Card Troubleshooting

The following are instructions on how to troubleshoot the ADPCM card. This is in case the card fails for any reason:

1. Green LED on faceplate.
2. Verify that the card is in the right slot, P1 through P3.
3. Reseat the card if necessary. This can be done with the power on.
4. View the card status on the main screen.
5. Check the cards configuration options. Select the card from the main screen to do this.
6. Now try to log into the ADPCM main screen. If this still didn't work the card may be bad. Try swapping it with a new card.
7. If the ADPCM card is determined to be faulty, replace it and return the faulty unit for repair to the location specified by your distributor.

19.6 ADPCM Server Card Specifications

ADPCM Card (887170)

Input Voice Channels	Can originate from any 2-wire or 4-wire voice card or from a DSO on a WAN (E1/T1 or HDSL) interface. μ -law & A-law 64Kbps PCM compatible on a per channel basis.
Input Sub-rate Data	SRU data traffic at 19.2Kbps or less can be carried on a 24Kbps sub-channel.
Input BRI traffic	B channel voice traffic can be compressed at any of the configurable rates.
Modem Data Support	Transcoder rate: 24, 32 or 40 Kbps; Modem Data: none, up to 4.8Kbps, V.32 to 9.6Kbps, up to 12Kbps and V.32 bis to 14.4Kbps
Fax Support	Transcoder rate for fax: 24, 32 or 40 Kbps; none, Group II and Group III fax.
Voice Quality	As measured by Mean Opinion Score (MOS) analysis, a subjective evaluation with a range of 0 (poor quality) to 5 (good quality). Toll quality voice is accorded a MOS of 4.0 24Kbps transcoder rate MOS is 3.6-3.8; 32Kbps transcoder rate MOS is 4.0-4.3 and 40Kbps transcoder rate MOS is 4.0-4.3
Echo Cancellation	Non provided—typically not required
Signaling	Transmitted in-band utilizing CAS transitional signaling, as per ANSI T1.302—1986 for 32Kbps and modified for use with 24Kbps and 40Kbps. Note Robbed Bit Signaling Alarm Transmission, as specified in ANSI T1.302a-1989 is not supported.
Maximum Card Count	3 (2 active, 1 redundant)
Transcoder Operation	Compliant to G.761 Alarm Indication and Fault Handling.

Standards Compatibility

ANSI	T1.302 1989
	T1.302a 1992
	T1.303 1989
CEN	EN 500 081-1
	EN 500-092-1
	EN 60950/A2
ITU-T	G.721
	G.723
	G.726 12/90

Chapter 20

Analog Bridging Server Card

20.1 Introduction

This chapter provides installation, configuration, and troubleshooting information for the Analog Bridging Server Card, (885070).

20.2 Analog Bridging Server Card Description (885070)

The Analog Bridging Server Card is a plug-in server card which allows the analog voice band signals from up to thirty two voice circuits to be combined (bridged). In the case of the IMACS application, each analog circuit is a DS0 channel carrying analog traffic from an access card port such as a FXS, 4W E&M, 2W E&M or from a WAN port. Although this traffic originates as an analog signal, it is bridged digitally in the Analog Bridge card after it has been digitalized into a DS0. The bridge itself is set up via the provisioning interface on the IMACS maintenance terminal. Once the bridge is set up, the circuits remain permanently bridged until the provisioning is changed. There is no supervision (on/hook or off/hook) or signaling (digit dialing) involved with circuits that are bridged. End-users can not dynamically add or delete themselves from the bridge, making this a permanent telephone conference bridge with no dynamic end-user control.

The 885070 Analog Bridging card can support up to 240 total DS0 circuits. There are 80 bridges available, and each bridge is capable of joining 32 subscribers. Echo cancellation and half duplex options are available.

20.2.0.1 Card Jumper/Switch Settings

The Analog Bridge Server Card has no jumpers. The card illustrated in Figure 20-1 below.

Figure 20-1. Analog Bridge Server

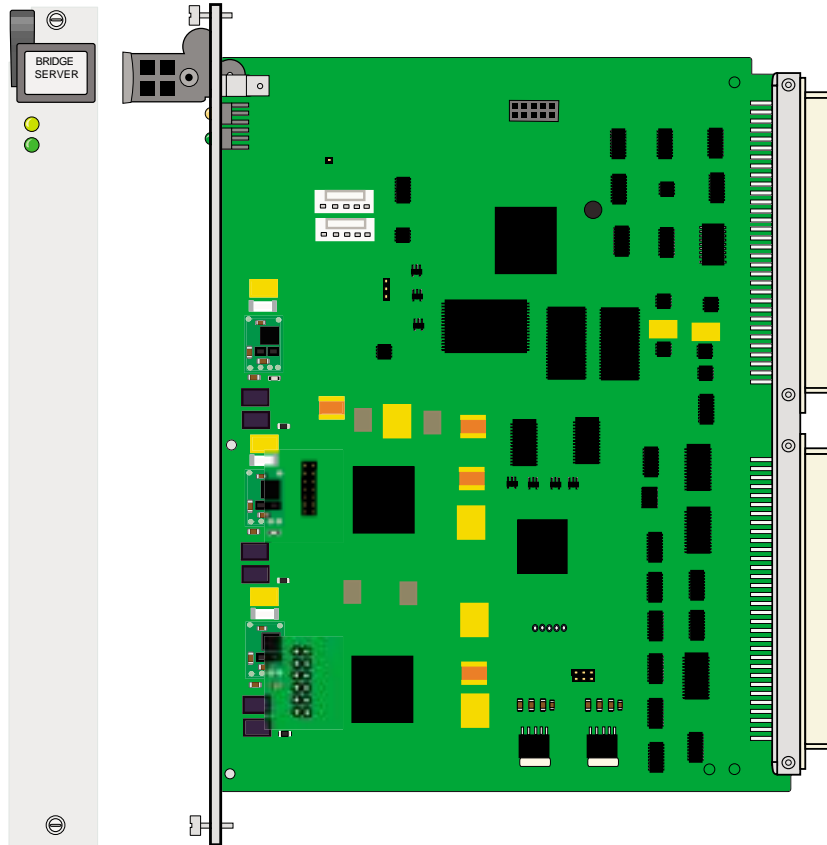

20.2.0.2 Installing the Analog Bridge Server Card

Insert the Analog Bridge Server card into any server card slot. These slots are P1 to P3 on the two-sided chassis or the front-loading chassis with power supplies on top (800 or 900 shelf), or P1 to P3 and U1 to U3 on the front-loading chassis with power supplies on the side (600 shelf).

Each system can have up to two Analog Bridge Server cards installed. The Analog bridge card also offers a redundant option, enabling the bridges to have a protection mechanism.

20.3 Analog Bridge Server Card User Screens and Settings

20.3.1 Analog Bridge Provisioning

Bridge setup and participant provisioning is done from the Analog Bridge card itself. To start potential bridge participants should be in an un-provisioned state, or in stdby mode at the card/port level.

20.3.2 Analog Bridge Server Card Main Configuration Screen

On the Analog Bridge card main configuration screen, all the bridges will show up initially in standby mode. When a Bridge is in standby mode, all ports on that particular bridge will be turned off automatically. The bridge must be active in order to activate the individual ports.

To enter the provisioning screen, position on the Bridge card from the main IMACS window and depress carriage return. A screen similar to Figure 20-2 below appears.

Analog Bridge	P3	BRIDGE	Rev A1-0	Ser 00005	06-06-12 09:21			
Version #:1.0.4								
	1	2	3	4	5	6	7	8
BRIDGE ST.	actv	actv	actv	actv	stdby	stdby	stdby	stdby
MAX PORTS	16	8	6	19	0	0	0	0
PORTS USED	3	3	3	3	0	0	0	0
BRDG TYPE	voice	voice	voice	voice	voice	voice	voice	voice
GAIN	0dB	0dB	0dB	0dB	0dB	0dB	0dB	0dB
Save	Undo	Refr	Copy	<	>	sWitch	Ports	All ports
Goto	Main							

Figure 20-2. Analog Bridge Server main screen

The bottom highlighted line of this screen shows various actions that you can perform from this screen. You perform the desired action by pressing the associated uppercase key. Table 20-1 summarizes these actions. For example, after you configure the Analog Bridge Card ports, press “s” to save your settings.

Table 20-1. Analog Bridge Main Screen Actions

Action	Function
Save	Saves changes to settings.
Undo	Returns all settings to the last saved state.
Refr	Refresh - Updates certain time-related information fields that are not automatically updated (i.e., test status). Refresh will also compact and reorder all the ports in the LogUNIT sequence.

Copy	Copies the contents of the current column to the next column. Useful if you change a lot of entries in one column and want to repeat those changes in subsequent columns.
<	View the previous eight bridges
>	View the next eight bridges
sWitch	Switch the card with the redundant card
Ports	Displays the Ports assigned to the selected Bridge.
All ports	Displays all Ports assigned to any bridge.
Goto	Goto a user specified bridge number
Main	returns to the Systems Main Screen. If changes are made to settings and not saved, you will be prompted to either save or lose your changes.

Table 20-2 summarizes the configuration settings for the Analog Bridge Server Card, along with the available and factory-default option settings. The parameters and settings are also described in the following paragraphs.

Table 20-2. Analog Bridge Main Screen Option Settings and Defaults

Parameter	User Options	Default
BRIDGE ST.	stdby actv rdnt	stdby
MAX PORTS	Provision the bridge with up to 32 participants	0
PORTS USED	This field is Display Only, from 0 to 30 ports	n/a
BRDG TYPE	voice	voice
GAIN	0dB -3dB -6dB	0dB

BRIDGE ST.

The State setting determines whether the Bridge is active or inactive. An inactive Bridge does not occupy a time slot on a WAN link. Set the state setting to **stdby** (standby) for Bridges that are not being used or have not yet been configured. Set it to **actv** (active) for Bridges that are ready for use.

MAX PORTS

This number is set by the user to define the number of ports to assign to the bridge, from 2 to 32.

NOTE: increasing this number requires that the bridge be taken out of service. If a bridge may grow one day, it may be advisable to over-provision the number of ports. If a three-port bridge is needed, the operator could see the potential for growth and set this number to five. If in the future a fourth and fifth participant needs to be added, then this can be done without taking the bridge out of service since the max ports setting allows for growth. If however max ports is set to match the current requirement of three, then the bridge would need to be taken out of service for a fourth participant to be added.

PORTS USED

The Ports Used field is a display-only field. It reflects the number of ports (subscribers) that are assigned to the particular Bridge.

BRDG TYPE

This is for fur future development, currently only **voice** is supported.

GAIN

The gain setting allows for a specified gain to be applied to the bridge itself. All subscribers will be attenuated to the assigned settings. Valid settings are: **0dB**, **-3dB** and **-6dB**

When provisioning a bridge, keep in mind that to expand the size of the bridge (max ports) the bridge must be put into standby mode before making the bridge larger to add a new participant. Placing an active bridge to stdby mode will not only put the bridge in standby, but will also automatically place into standby all the participants on the bridge. As this action takes the bridge out of service, it may be advisable to over-provision a bridge in order to accommodate for growth. For example, let's say bridge number one will have three participants. Max ports can therefore be set to three. If however a new participant needs to be added, the bridge will need to be put into standby mode and then max ports changed to four participants. On the other hand, if the initial setting for Max ports was four or higher, then the new participant could be added to the bridge without taking the bridge down first, as this number had already been engineered for growth. Any change made to the bridge as a whole (Gain, Max ports or the bridge type) requires that the bridge be taken to the standby status.

Analog Bridge	P1/U1	BRIDGE	Rev	A1-0	Ser	00023	02-21-12	06:00		
Version #: 1.0.4										
	1	2	3	*5	6	7	8			
BRIDGE ST.	stdby	stdby	stdby	stdby	actv	stdby	stdby	stdby		
MAX PORTS	0	0	0	0	30	0	0	0		
PORTS USED	0	0	0	0	0	0	0	0		
BRDG TYPE	voice	voice	voice	voice	voice	voice	voice	voice		
GAIN	0dB	0dB	0dB	0dB	0dB	0dB	0dB	0dB		
Enter number <0 - 32>: 30										
Save	Undo	Refr	Copy	<	>	sWitch	Ports	All ports	Goto	Main

Figure 20-3. Configuring a bridge - bridge 5

In the example shown in Figure 20-3 above, the user is setting up bridge five to contain 30 participants. To save the information and provision the new bridge, the user simply hits 'S' for save. Once done, this bridge has been defined and is ready for adding participants.

20.3.3 Port Provisioning on the Bridge

In order to provision the participants for the bridge, the user should position on the bridge to be edited, and depress the 'p' key for Ports. This will take the user to a screen similar to the one seen below in Figure 20-4

Node 13		P2 BRIDGE		Rev A2-0		Ser 00078		12-18-12 12:42	
Version #: 1.0.5									
	*1	*2	*3	4	5	6	7	8	
STATE	actv	actv	actv	stdby	stdby	stdby	stdby	stdby	
BRIDGE	05	05	05	05	05	05	05	05	
USER	U4	none	U8	none	none	none	none	none	
WAN	none	w3-1	none	none	none	none	none	none	
TS/PORT	08	21	07	n/a	n/a	n/a	n/a	n/a	
SIG MODE	none	none	none	none	none	none	none	none	
CODING	n/a	u-law	n/a	n/a	n/a	n/a	n/a	n/a	
SUB CHAN	n/a	1	n/a	n/a	n/a	n/a	n/a	n/a	
RX MODE	hdplx	hdplx	hdplx	hdplx	hdplx	hdplx	hdplx	hdplx	
TX MODE	na	na	na	na	na	na	na	na	
ECHO CAN	disab	disab	disab	disab	disab	disab	disab	disab	
GAIN	0.0	0.0	0.0	0.0	0.0	0.0	0.0	0.0	
logUNIT	xx	xx	xx	xx	xx	xx	xx	xx	
Save Undo Refresh Copy Bridges Names < > Main									

Figure 20-4. Bridge Port Screen

In Figure 20-4 above, we are now looking at the participant list for bridge five. All ports allocated to this bridge have the bridge number (05) assigned to them, with ports four through eight reflecting the default setting for unassigned participants. On ports one, two and three some participants are being provisioning for use on the bridge. As can be seen, ports one and three are going to user cards in slot U4 port 8 and U8 port 7, respectively. Port two above shows the addition of a participant being added into the bridge from a WAN timeslot, in this case WAN 3-1 and timeslot 21. This information can then be saved, and these three participants are now combined into an active bridge. This information is in turn reflected at the main bridge screen as shown in Figure 20-5 where the bridge in use reflects the three active participants out of thirty-two possible.

Table 20-3. Analog Bridge Port Screen Actions

Action	Function
Save	Saves changes to settings.
Undo	Returns all settings to the last saved state.

Analog Bridging Server Card Analog Bridge Server Card User Screens and

Refresh	Refresh - Updates certain time-related information fields that are not automatically updated (i.e., test status). Refresh will also compact and reorder all the ports in the LogUNIT sequence.
Copy	Copies the contents of the current column to the next column. Useful if you change a lot of entries in one column and want to repeat those changes in subsequent columns.
Bridges	Selecting bridges goes back to the main bridge screen.
Names	This field (introduced in 7.1.2) allows the user to name the bridge participant with a fourteen character strings.
<	View the previous eight bridges
>	View the next eight bridges
Main	returns to the Systems Main Screen. If changes are made to settings and not saved, you will be prompted to either save or lose your changes.

Table 20-4 summarizes the configuration settings for the Analog Bridge Server Card, along with the available and factory-default option settings. The parameters and settings are also described in the following paragraphs.

Table 20-4. Analog Bridge Port Screen Option Settings and Defaults

Parameter	User Options	Default
STATE	stdby actv	stdby
BRIDGE	Display only	01
USER	none U1 U2 U3 U4 U5 U6 U7 U8	none
WAN	none w1-1 w1-2 w2-1 w2-2 w3-1 w3-2 w4-1 w4-2	none
TS/PORT	01 through 32	n/a
SIG MODE	none e&m to	none
CODING	u-law a-law adpcm g729b modem	n/a
SUB CHAN	1 through 5	n/a
RX MODE	hdplx fdplx	hdplx
TX MODE	na	na
ECHO CAN	disab enabl	disab
GAIN	-15.0 through 7.5	0.0
logUNIT	Display Only	xx

STATE

This field displays the currently set port state, either active or standby

BRIDGE

This field is a display-only field that shows the bridge number the port is assigned to. At this level, all the bridges will display the same number.

USER

This field can be chosen to add a participant from a User card, U1 through U8.

WAN

This field is used to choose to add to a bridge a WAN port. Available are WAN 1-1 through WAN 4-2.

TS/PORT

This field is used to identify the timeslot (in the case of a WAN) or port in the case of a User card that is assigned to the bridge. From 01 through 32. For user ports, 1 through 8 are selectable. If WAN, then the maximum number will be 24 for T1, and 32 for E1 mode.

SIG MODE

The signaling mode is set to either E&M or TO. Currently signaling is not supported on the bridge.

CODING

For future development. Currently u-law and a-law will be filled in if the subscriber is using T1 or E1 mode, respectively.

SUB CHAN

For packed DS0's when using compression, the user can select the sub channel. Currently not used.

RX MODE

The user can select half for full duplex mode. Half duplex prevents the user from hearing their own input into the bridge, and is the default setting.

TX MODE

The TX mode is for future use, only na is available.

ECHO CAN

Echo cancellation is used to prevent feedback disturbances on the parties line. The default is set to disable.

GAIN

The gain for circuits can be set from this screen. Valued individual port gain settings are -15dB to +7.5dB

logUNIT

This display-only field shows the logical unit assigned to this port, useful when using the all ports sub-menu.

When a port is assigned to a bridge and saved, the three participants seen in Figure 20-4 are now combined into an active bridge. This information is in turn reflected at the main bridge screen as shown below in Figure 20-5 where the bridge in use reflects the three active participants out of thirty-two possible.

Analog Bridge	P1/U1	BRIDGE	Rev	A1-0	Ser	00023	02-21-12	0		
Version #:1.0.4										
BRIDGE ST.	1	2	3	4	5	6	7	8		
	stdby	stdby	stdby	stdby	actw	stdby	stdby	stdby		
MAX PORTS	0	0	0	0	30	0	0	0		
PORTS USED	0	0	0	0	3	0	0	0		
BRDG TYPE	voice	voice	voice	voice	voice	voice	voice	voice		
GAIN	0dB	0dB	0dB	0dB	0dB	0dB	0dB	0dB		
Save	Undo	Refr	Copy	<	>	sWitch	Ports	All ports	Goto	Ma

Figure 20-5. Bridge 5 - three ports in use

The normal display of the individual user cards in use on a bridge will indicate their inclusion on a bridge as a participant as seen in Figure 20-6 below. The information seen in the figure below is noted as being bridge participants in the WAN/SRV field. The nomenclature is the server slot location as the first two digits (1P, 2P or 3P), followed by the three-digit identifier of the port. In the case of port 7 (which we have added to bridge 5), this port indicates it is in use on the card in the first server slot (1P), and is assigned to the logical port number on the server card slot to number 008. We can also see from this user card display that ports one and two are also assigned to a bridge on the first server slot.

Analog Bridge W4/U8 FXS 2Wx8-6 Rev A2-0 Ser 07183 04-13-12 15:14								
	1	2	3	4	5	6	7	8
STATE	actv	actv	stdby	stdby	stdby	stdby	actv	stdby
WAN/SRV	1P001	1P002	none	none	none	none	1P008	none
TS	n/a	n/a	n/a	n/a	n/a	n/a	n/a	n/a
MODE	e&m	e&m	e&m	e&m	e&m	e&m	e&m	e&m
R2 TYPE	n/a	n/a	n/a	n/a	n/a	n/a	n/a	n/a
Rx TLP	0.0	0.0	0.0	0.0	0.0	0.0	0.0	0.0
Tx TLP	0.0	0.0	0.0	0.0	0.0	0.0	0.0	0.0
CODING	u-law	u-law	u-law	u-law	u-law	u-law	u-law	u-law
TC CGA	idle	idle	idle	idle	idle	idle	idle	idle
LB	off	off	off	off	off	off	off	off
PATTRN	none	none	none	none	none	none	none	none
HYBRID	n/a	n/a	n/a	n/a	n/a	n/a	n/a	n/a
SIG CONV	n/a	n/a	n/a	n/a	n/a	n/a	n/a	n/a
RATE	64K	64K	64K	64K	64K	64K	64K	64K
ADPCM	n/a	n/a	n/a	n/a	n/a	n/a	n/a	n/a
Save Undo Refresh Copy Test Dial Main								

Figure 20-6.E&M card screen

20.3.4 All ports Screen

Keeping with the example running through this document, one can view and/or validate the provisioning information through the use of the All ports option. This command displays all ports available to the Bridge card itself (there are 240 logical ports available) and displays them in groups of eight. Looking at the previous illustration shown in Figure 20-6, we have some interest in ports on the first Bridge card, and logical ports 001, 002 and 008. (1P001, 1P002 and 1P008). Below in Figure 20-7 is the display at the Bridge card, using the All ports command.

Analog Bridge		P1/U1	BRIDGE	Rev A1-0	Ser 00023	02-21-12 06:31		
Version #:1.0.4								
	1	2	3	4	5	6	7	8
STATE	actv	actv	stdby	stdby	actv	actv	actv	actv
BRIDGE	14	14	14	14	14	05	05	05
USER	U8	U8	none	none	U5	U4	none	U8
WAN	none	none	w2-1	w3-1	none	none	w3-1	none
TS/PORT	01	02	01	01	01	08	21	07
SIG MODE	e&m	e&m	none	none	e&m	e&m	none	e&m
CODING	n/a	n/a	u-law	a-law	n/a	n/a	a-law	n/a
SUB CHAN	n/a	n/a	1	1	n/a	n/a	1	n/a
RX MODE	fdplx	fdplx	hdplx	hdplx	fdplx	fdplx	fdplx	fdplx
TX MODE	na	na	na	na	na	na	na	na
ECHO CAN	disab	disab	disab	disab	disab	disab	disab	disab
GAIN	0.0	0.0	0.0	0.0	0.0	0.0	0.0	0.0
logUNIT	001	002	003	004	005	006	007	008
Save Undo Refresh Copy Delete Bridges < > Goto Main								

Figure 20-7. Bridge All Ports command

Figure 20-7 shows ports 001, 002 and 008 in the logUNIT field being connected to User card U8. We can also see that the seventh port displayed is connected to our newly provisioned bridge number 5, and shows us that ports 1 and 2 on card U8 are connected to Bridge number 14. In addition, we can see that all the ports here are assigned to either bridge 5 or 14 and go to various cards and WAN busses. We can also see that some are active and others are in standby along with their respective services which they carry.

Once ports have been assigned to the bridge, placing them standby allows changes on these lines, but they will still be part of the assigned bridge and taking up resources. The illustration seen below in Figure 20-8 shows the port screen for bridge 14. It shows two active E&M lines on card U8 (participant 1 and 2), and three connections that are part of bridge 14 even though they are in standby status (participants 3, 4 and 5). These bridge resources are still active participants, as they have a logUNIT assigned, as seen in the circled data. At the main screen, the bridge count for bridge number 14 will show five ports in use - even though some (participants 3, 4 and 5) are in the standby status. In order to remove these participant resources from the bridge, the port must first be put into standby mode here in the ports screen, and then the user can remove the participant from the bridge at the All ports screen.

Analog Bridge		P1/U1	BRIDGE	Rev A1-0	Ser 00023	02-22-12 03:54		
Version #: 1.0.4								
	1	2	3	4	5	6	7	8
STATE	actv	actv	stdby	stdby	stdby	stdby	stdby	stdby
BRIDGE	14	14	14	14	14	14	14	14
USER	U8	U8	none	none	U5	none	none	none
WAN	none	none	w2-1	w3-1	none	none	none	none
TS/PORT	01	02	01	01	01	n/a	n/a	n/a
SIG MODE	e&m	e&m	none	none	e&m	none	none	none
CODING	n/a	n/a	u-law	a-law	n/a	n/a	n/a	n/a
SUB CHAN	n/a	n/a	1	1	n/a	n/a	n/a	n/a
RX MODE	fdplx	fdplx	hdplx	hdplx	fdplx	fdplx	fdplx	fdplx
TX MODE	na	na	na	na	na	na	na	na
ECHO CAN	disab	disab	disab	disab	disab	disab	disab	disab
GAIN	0.0	0.0	0.0	0.0	0.0	0.0	0.0	0.0
logUNIT	001	002	003	004	005	xx	xx	xx
Save Undo Refresh Copy Bridges < > Main								

Figure 20-8. Bridge 14 display - ports on the bridge

To remove a participant and the resource from a bridge, you must use the delete function at the All ports level. From the All ports level, the user can either set the bridge number on the ports to be removed to zero (00), or use the delete command to remove them from the bridge. This is illustrated below in Figure 20-9, where logUNIT port 6 shows no assignment in any bridge, as circled. This action makes this logical port ready for assignment into another bridge, and as can be seen below - all other ports here are part of bridges and taking up bridge resources. Logical ports 7 and 8 below are still active participants on bridge number 05, even though they are in standby mode.

Analog Bridging Server Card Analog Bridge Server Card User Screens and

Analog Bridge	P1/U1	BRIDGE	Rev A1-0	Ser 00001	04-13-12 08:56			
Version #:1.0.4	1	2	3	4	5	6	7	8
STATE	actv	actv	actv	actv	actv	stdby	stdby	stdby
BRIDGE	14	14	14	14	14	xx	05	05
USER	U8	U8	U5	U5	U5	none	none	U8
WAN	none	none	none	none	none	none	w3-1	none
TS/PORT	01	02	01	02	03	n/a	21	07
SIG MODE	e&m	e&m	e&m	e&m	e&m	none	none	e&m
CODING	n/a	n/a	n/a	n/a	n/a	n/a	a-law	n/a
SUB CHAN	n/a	n/a	n/a	n/a	n/a	n/a	1	n/a
RX MODE	fdplx	fdplx	fdplx	fdplx	fdplx	fdplx	fdplx	fdplx
TX MODE	na	na	na	na	na	na	na	na
ECHO CAN	disab	disab	disab	disab	disab	disab	disab	disab
GAIN	0.0	0.0	0.0	0.0	0.0	0.0	0.0	0.0
logUNIT	001	002	003	004	005	006	007	008

Save | Undo | Refresh | Copy | Delete | Bridges | < | > | Goto | Main

Figure 20-9.All ports - delete a port

Performing the action in the All ports screen of setting the bridge number to zero or deleting them will result in the circled field displaying the logUNIT numbers to transition to 'xx' as seen on logical port 6 above. This action deallocates the port from any bridge, making it available for future use.

20.4 Analog Bridge Server Card Specifications

Analog Bridge Card (885070)

Physical Interface (Model 885070)

Card Height	8 inches (20 cm)
Card Width	15/18 inches (2.35 cm)
Card Depth	7.5 inches (18.75 cm)
Power Consumption	6.74 Watts
BTU per hour	23.0
Operating Temperature	0 to 50 C, 32 to 122 F
Storage Temperature	-20 to 80 C, -4 to 176 F
Humidity	0 to 95% humidity, non-condensing

IMACS Platform Support

IMACS Chassis	891630 IMACS 600 891830 IMACS 800 891930 IMACS 900
Control CPU Support	880370 or 880770 cross-connect CPU with Ethernet support
Software Requirement	6.2.2, 7.1.0 or later
Interface Card Support	892260, 892360 or 892460 for CPU-6, 893270, 893370 or 893470 for CPU-7
Power Supply Options	All AC/DC power supplies are supported

Card Interface

Input Voice Channels	Any 2-wire or 4-wire voice card, or from a DS0 on a WAN (E1/T1) Mu-law 64Kbps PCM only is supported.
Maximum Card count	2 per shelf
Bridge Maximum	Maximum of eighty per card
Maximum DS0's per Shelf	Two hundred and forty per bridge
Maximum Bridged DS0's per shelf	Sixty-two DS0's can be bridged in a shelf (see note)

Chapter 21

IPR*4 Router Card

IPR*4 Card Basics

21.1 Introduction

This chapter provides installation, configuration, and troubleshooting information for the IPR*4 Router Card. This card is labeled as the IPR*4 10/100BT SS (PRM-883270) card on the faceplate ejector.

21.2 IPR*4 Router Card Descriptions

21.2.1 IPR*4 Router 10/100BT Card Description (PRM-883270)

The IPR*4 card provides a PPP or HDLC backbone for customers to extend their communications, command and control capability in an IMACS network. This card extends the capability of the IMACS shelf to expand the range of control in the customers private network.

The IPR*4 card introduces to the IMACS platform a synchronous standard implementation of PPP, RFC 1661. It also provides replacement technology for the MCC card, by the support of HDLC links to the remote shelves.

In order to provide the Ethernet to PPP or HDLC inter-working capability, the IPR*4 10/100BT card has four modular RJ45 interface ports on the faceplate.

The software release level in the card determines the cards capabilities. The following illustrates the current and future direction of this card, and appropriate display names.

Table 21-1. IPR*4 available options

Card Display	Firmware	Faceplate Ethernet Ports	Transport Links	High Speed Ports	Status
IPR*4PPP	1.1.x	Individually Addressable	128 PPP	Yes, 4	2011 Released
IPR*4 PPP HS	1.2.x	Individually Addressable	8 PPP	Yes, 8	2013 Released
IPR*4HDLC	2.0.x	Individually Addressable	128 HDLC	Yes, 4	2012 Released
IPR*4FR	3.x.y	Individually Addressable	128 FR	Yes, 4	TBD

The IPR*4 10/100BT Cards are IP routers that route packets based on IP destination addresses. IPR*4 routes IP datagrams between Ethernet and PPP T1's, or HDLC framed T1's.

IPR*4 supports SNMP for Ethernet, IP and Routing MIBs. It uses the standard Ethernet encapsulation, utilizing 14 bytes Ethernet Header: Source Ethernet Address (6 bytes), Destination Ethernet Address (6 bytes), and a Protocol Type (2 bytes). The IPR*4 card supports RIP (Routing Information Protocol, RFC 1058) as well as RIPv2, used for dynamically discovering IP routes from adjacent IP routers.

The WAN interface is standard encapsulation of IP datagrams over a PPP link, or over an HDLC link.

The IMACS IPR*4 card does not support PPP authentication. The IPR*4 card is not designed to be a general purpose enterprise router, but rather is designed to extend the IMACS network of command and control applications contained within the customers T1/E1 network.

IPR*4 provides the capability to deliver IP packets to the CPU hosting the IPR*4. Assuming an average frame of 256 bytes, IPR*4 maintains LAN to WAN (and WAN to LAN) throughput of 2.048 Mbps.

Figure 21-1. IPR*4 Card Layout

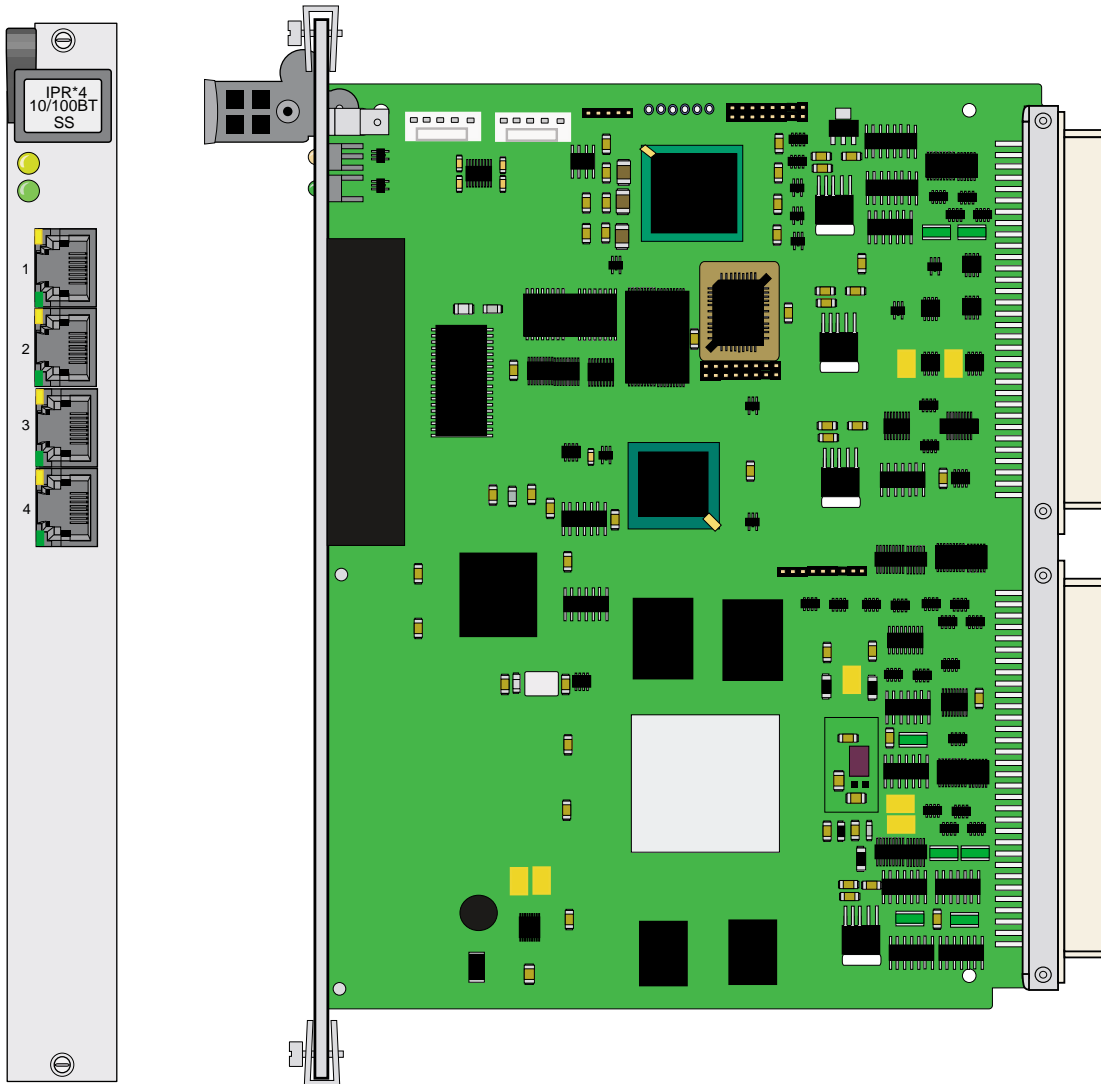

21.2.1.1 Card Jumpers/Switch Settings

The IPR*4 card does not have any jumpers or switches on the motherboard.

21.2.2 Installing the IPR*4 Cards

Insert the IPR*4 10/100BT card into one of the server card chassis slots (P1 to P3). The system can accommodate one IPR*4 server card.

21.3 IPR*4 configuration in a PPP or HDLC Network

In the IPR*4 1.1.x release, the four ethernet ports are individually addressable and the card supports 128 PPP links. With 1.1.x loaded on the IPR*4 card, it displays IPR*4PPP.

In the IPR*4 2.0.x release, the four ethernet ports are individually addressable and the card supports 128 HDLC links. With 2.0.x loaded on the IPR*4 card, it displays IPR*4HDLC.

21.3.1 IPR*4 Connecting IP LANs

The IPR*4 Card can be used for connecting IP LANs together through a PPP or HDLC Network. Figure 21-2 shows a T1 PPP or HDLC network between three Ethernet LANs.

Figure 21-2. IPR*4 Card Connected to IP LANs through a PPP Network

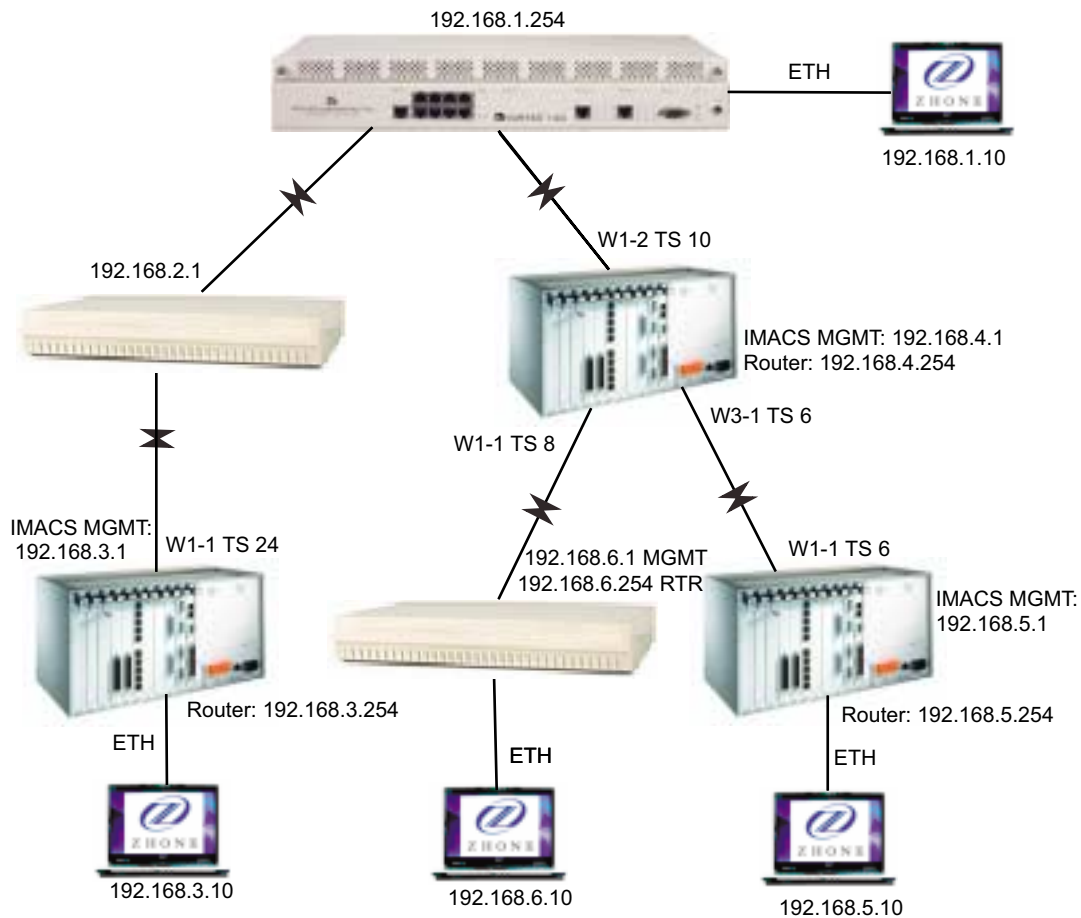

21.4 IPR*4 Card Configuration Screens and Settings

21.4.1 IMACS Main Screen

```

ZhoneIMACS | 03-24-11 1
-----|-----
Slot   Installed   Status
-----|-----
C1     CPU XCON    asss
C2     CPU XCON    RDNT
P1/U1  IPR*4S     aaaa
P2/U2  IPR*4PPP   REJ
P3/U3  DSM-4      ssss
U4/U4  E&M 4Wx8-6 ssssssss
W1/U5  DSX+DSX    aa
W2/U6  DSX+DSX    aa
W3/U7  DSX+DSX    aa
W4/U8  DSX+DSX    rr
IF     INTF-Sync
S1     PS1
S2
RI

The UI will update when the ACCEPT command has completed.

Alarms | Config | Del | accept | Xcon | sYs | Logout | sEr | Oos | cpusWtc

```

Figure 21-3. IPR*4 card interactions

The IPR*4 card displays the four ethernet ports and their current status on the main login screen. The WAN PPP or HDLC link ports are not displayed at this level.

The IPR*4 card supports 128 PPP or HDLC WAN links. The interface on the WAN links - either PPP or HDLC - is determined by the software loaded on the card. The first four of these WAN links can be provisioned to transport a full T1 or E1 range of available DS0's. When utilizing these four high-speed links, the DS0 assignment must be contiguous. Because of the WAN interface to 128 T1 or E1 ports, the IPR*4 card takes longer than other IMACS server cards to initialize on power-up and restarts. As shown in Figure 21-3, system interactions take longer when dealing with the IPR*4 card as in the case of accepting the card from a rejected state (REJ). This particular action causes the user interface (UI) updates to cease as the IMACS provisions and establishes the 128 PPP or HDLC WAN link configuration. The IMACS continues to operate during this time, however the UI cannot be updated until the task completes.

21.4.2 IMACS Management Through the IPR*4 Card

```

ZhoneIMACS | C1 CPU XCON | Rev C2-0 Ser 01373 | 08-16-10 1
1
HOST IP STATE      actv
HOST IP ADDR       172.16.73.113
HOST NETMASK       255.255.255.0
HOST TYPE          host
DEFAULT IP PORT    servr
DEFAULT IP SLOT    P2
DEFAULT IP UNIT    n/a
DEFAULT GATEWAY    n/a
RPT1 IP ADDR       0.0.0.0
RPT1 COMMUN STR
RPT2 IP ADDR       0.0.0.0
RPT2 COMMUN STR
RPT3 IP ADDR       0.0.0.0
RPT3 COMMUN STR

Ping | Netstat | rOute | Save | Undo | Refresh | nX64 | Main

```

Figure 21-4. Setting the CPU management through the IPR*4 card

The system can be configured in such a way as to allow the IMACS management port to come over the PPP or HDLC link. Figure 21-4 shows the setup to manage this IMACS node through the IPR*4 card. The default IP port noted in the figure is pointed to the IPR*4 server card, which in this example resides in slot P2. Please note that when managing the IMACS through the IPR*4 card, a change to the IMACS host CPU IP address may require that the IPR*4 card be restarted (placed OOS) in order for the new IMACS IP address to be accessible.

21.4.3 IPR*4 10/100BT (883270) Card Main Screen

The main screen of the IPR*4 screen gives the operator the current interface setup of the card by displaying the current routing table for the card. This main screen is shown in Figure 21-5.

```

Node 13 | P1 IPR*4PPP Rev A0-0 Ser 10000 | 03-25-11 13:39
Version #:1.1.0
IP Router Routing Table

#      Route          Dist    Next Hop      Interface      Status      S
1  172.16.55.0        1      172.16.55.55  13_PC         D....      G
2  172.16.13.0        1      172.16.55.55  NODE23        D....      G
3  172.16.73.23       2      172.16.13.13  NODE23        ....R      G
4  172.16.73.13       1      172.16.73.13  HOST RT       ..H..      G

Total # Of IP Routes : 4

STATUS :   D=DIRECT   S=STATIC   H=HOST   F=DEFAULT   R=RIP
S(STATE):  G = GOOD    P = SUSPECT B = BAD

Refresh | pgUp | pgDn | eNet | Stat | porT | Intf name | nEtst | Ping |

```

Figure 21-5. IPR*4 10/100BT Card Interface Main Screen

The default IPR*4 screen shows the current software level of the IPR*4 card, as well as all the routes visible to the IPR*4 card. The Interface column displays the interface name as assigned either in the Intf name window or from PPP discovery messages. In addition it displays the way that this information was obtained, either by rip or static entries. Finally, the display indicates if the route is good, bad, or suspect. A GOOD route is one that has recently been updated. A SUSPECT route is one that the system has not had a RIP update for 90 seconds. A BAD route is one that has passed the suspect stage, and is declared BAD after the lapse of an additional 30 seconds. Once a BAD route has existed for an additional 30 seconds, it will be deleted from the routing table.

Table 21-2. IPR*4 10/100BT Card Main Screen Actions

Action	Function
Refresh	Refresh the current screen.
PgUP	Scrolls up one page.
PgDn	Scrolls down one page.
eNet	Go to Ethernet and Default IP screen.
Stat	Go to Static Route configuration screen.
Port	Go to the PPP Port provisioning screen.
Intf name	Define the Interface name and associate it to an IP address
Ping	Allows for sending a ping out from the IPR*4 card
Main	Go back to the IP Interface Main Menu Screen.

The 1.1.x software release of the IPR*4 card is a PPP interface device. These four RJ-45 ethernet ports are independently addressable, and the card can interface with up to 128 PPP WAN links. In order to provision and control the interface, the use of the settings on the IPR*4 main screen needs to be defined. As shown in Table Table 21-2 and figure Figure 21-5, these parameters are **eNet**, **Stat**, **porT** and **INTF NAME**. For the PPP port-side interface, the **INTF NAME** screen is not used as discovery messages on the PPP link will associate an IP address to the link.

The 2.x.y software release of the IPR*4 card is an HDLC interface device. Similar to the PPP interface, the four ethernet ports are also independently addressable, as well as having 128 HDLC WAN links. As with the PPP implementation, the first four HDLC ports (port 1 through 4) are high speed (up to a full T1 or E1 each) links, while the remaining 124 links are single DS0 entities.

21.4.4 IPR*4 provisioning card setup

The basic premise of the IPR*4 card is to connect IP addressable entities from the four provided ethernet RJ-45 jacks on the faceplate of the card to a remote management system over T1 or E1 links. For this purpose, the setup of the card takes place in two venues: the ethernet side (**eNet**) and in the T1 or E1 port (**porT**) side. Connectivity occurs due to the IPR*4 card being able to associate IP addresses via RIP, RIPv2, static provisioning, PPP discovery, etc. The ethernet side always requires that the user describe this interface in the **INTF NAME** screen. This associates an IP address to a ethernet jack on the faceplate of the card.

On the T1/E1 side, similar association between an IP address and a link is required for the HDLC interface. An IP address is associated with a name in the **INTF NAME** screen in order to properly route packets. For the PPP interface - this association is not needed. The PPP interface discovers the far-end IP address through IPCP discovery messaging, and therefore an IP address association is made through the PPP protocol. Although the **INTF NAME** association is not needed, the ability to name a port for ease of discovery by the customer is provided in the PPP screen.

The card provisioning setup then is slightly different for PPP and HDLC systems, and the provisioning actions are summarized below.

Step 1: Add IP address to name associations in the **INTF NAME** screen for the four ethernet ports on the router card.

Step 2: Use the ethernet screen (**eNet**) to turn up in-service and provision the four ethernet ports. The name in step one is required to turn up the ethernet ports.

Step 3: For PPP links, skip to step 5. The card displays IPR*4PPP and router load indicates 1.x.y.

Step 4: For HDLC links - the card displays IPR*4HDLC and the router load indicates 2.x.y. Assign additional **INTF NAME** and IP address associations in the **INTF NAME** screen. The IP addresses entered correspond to the existing IP addresses that are to be managed at the far-end of the HDLC link.

Step 5: Go to the porT screen, and assign the WAN connections to the remote systems. For HDLC system, enter the name from the **INTF NAME** screen that contains the definition of the far-end IP address. For PPP systems, the IP address will be automatically discovered. You can provide a name on the porT screen to help locate the appropriate link later.

Step 6: Turn-up the porT, and the status should change to UP if all provisioning and WAN links are in the appropriate state and provisioned correctly.

21.5 IPR*4 Card Download

Most versions of the IPR*4 card will allow the downloading of new software onto the card. The initial release, 1.0.0, does not have this capability and must be returned to the factory for upgrading. All other releases of the IPR*4 software allows for the card to be field upgraded.

The currently running card software can be confirmed in one of two ways. Entering into the card main level, as seen in Figure 21-5 on page 21-7 shows the currently running software release on the top left-hand corner of the screen.

The second way to validate the currently running software release is covered in this section.

Care should be taken when downloading new code, as different code levels will impact the basic operation of the card.

The cards are set up in such a way as to provide new releases and fixes within the same code base. In order to further explain this, refer to Table 21-1 on page 21-2. The 1.0.x, 1.1.x, 2.x.y and 3.x.y loads contain basic functionality differences between the various streams, and this affects the provisioning of the card from the resident IMACS host code. For example, a 1.0.x card should normally only be updated with code from the 1.0.x family. Changing to the 1.1.x family of code will alter the basic function of the card, and down time will ensue since new provisioning will be required. Prior to upgrading the card, please take the time to ensure you are utilizing the correct code for the functionality that is required in the network.



Note: *If the first two digits of the load you are downloading do not match the existing load on the card, then basic functionality of the card will change, causing an outage on the card as new provisioning will be required!*

As with other downloadable cards, navigate the cursor to the card to be upgraded - in this case the IPR*4 card. Hit 'P' for program, and a window similar to Figure 21-6 will appear.

```

Flash Screen | P1/U1 IPR*4PPP | Rev A0-0 Ser 00010 | 03-25-11 1
BLOCK NUMBER:      1
STATUS              actv
MODEL              IPR*4PPP
VERSION            1.1.0
I.D.               1
CHKSUM             0x11FD6BEC

Kernel 1.1, Checksum 0x11FD6BEC

actv   deactv   dnload
Copy | Refresh | Main

```

Figure 21-6.IPR*4 download screen

The currently running IPR*4 software level is displayed in the VERSION field above.

Upon entry into this programming level, the cursor is positioned on the status of the card, the 'actv' field. To place new code in the IPR*4 card, depress the carriage return or enter key in this field. The three options shown above will appear as illustrated in the figure. Use the arrow keys to select '**dnload**', and hit carriage return to select the download option. As soon as the download option has been selected, an upgrade alarm will appear as shown in Figure 21-8.

21.5.1 tftp and xmodem upgrades

Traditionally, downloading allowed for two options: **xmodem** and **tftp**. New in the 6.1.4 release is the **xpress** option. The IPR*4 load is over four megabits in size. Although the xmodem method is offered, it is strongly recommended that the tftp option be selected. Choosing the xmodem method will work, but will take several hours to complete. The **tftp** and **xpress** selections offer downloading through the traditional interaction with the IMACS CPU, through the ethernet port on the CPU. The **tftp** process is the preferred process, as it provides user status indications and automated processes. Following are the questions and the appropriate responses in order to tftp a new load into the IPR*4 card:

- Mismatch retries: (1 - 40). Leave at the default of 20 and hit carriage return.
- Timeout retries: (1 - 10). Leave at default of 4 and hit carriage return

- IP Address of server: In the box provided, denote the IP address of the device running the tftp server software.
- File name: Enter in the box provided the load file to be retrieved. This will resemble something like iptr_1.1.00.bin.

If the loadname selected will results in a functionality change, then the user will be prompted that they will need to reprovision services as noted in Figure 21-7.

```
Flash Screen | P1 IPR*4HDLC Rev A0-0 Ser 00006 | 09-23-11 17:04
BLOCK NUMBER:      1                                UPGRADE P1
STATUS              Full
MODEL               IPR*4HDLC
VERSION             2.0.0
I.D.                1
CHKSUM              0x120C7C40

Kernel 2.0, Checksum 0x120C7C40

WARNING: This download will change the cardtype,
         And you will lose all your provisioning.
Continue (y/n)?

Copy | Refresh | Main
```

Figure 21-7. Configuration change - reprovisioning needed

Once the proper values have been set up, and communications to the tftp server has been established, then the load size still to be transferred will begin to decrement in the window as shown in Figure 21-8.

```
Flash Screen | P1/U1 IPR*4PPP Rev A0-0 Ser 00010 | 03-25-11 13:10
BLOCK NUMBER:      1                                UPGRADE P1
STATUS              full
MODEL               IPR*4PPP
VERSION             1.1.0
I.D.                1
CHKSUM              0x11FD6BEC

Kernel 1.1, Checksum 0x11FD6BEC

Press CTRL-X to abort transfer...
Bytes left: 4862376
Copy | Refresh | Main
```

Figure 21-8.An in-process IPR*4 card download

For a clean connection, this download should take less than five minutes. If during the transfer process it is determined that this action is not desired, simply executing ctrl-x during the download will stop the download process and return the card to executing the current code level. After the download has completed, the system will calculate the load checksum that was transferred, in order to assure that the load has been delivered successfully. Should the checksum fail, then the download process will need to be started once again. Normally the checksum validation passes, and then the IPR*4 card will begin to place the new software into its' on-board flash. This action performed by the card will make the newly downloaded code the running operating software. This step taken by the card cannot be interrupted, and doing so can cause programming issues on the IPR*4 card, requiring it to be returned to the factory. This next step is illustrated in Figure 21-9. Please note the cautions associated with this step!

```
Flash Screen | P1/U1 IPR*4PPP Rev A0-0 Ser 00010 | 03-25-11 13:37
BLOCK NUMBER:      1                                UPGRADE P1
STATUS              full
MODEL               IPR*4PPP
VERSION             1.1.0
I.D.                1
CHKSUM              0x11FD6BEC

Kernel 1.1, Checksum 0x11FD6BEC

IPR*4 download has completed. The IPR*4 card takes up to
15 minutes to update its flash. The UPGRADE alarm will
clear when the upgrade is complete.
You will not be able to change the status of this IPR*4 card!
The card will restart automatically when completed.

Copy | Refresh | Main
```

Figure 21-9. Checksum passed, writing load to flash.

WARNING! Once the card begins to write to flash, any disruption in this process could cause the card to become inoperable, and would require the card to be returned to Zhone for repair. DO NOT remove the card during this time! DO NOT attempt to change the status of the card! DO NOT drop power on the IMACS shelf!

After the IPR*4 card completes writing to flash, the card will reboot and the upgrade alarm will be cleared. The new code is now executing on the IPR*4 card.

Should the card now have new functionality (one of the first two load digits has changed), then the card will be placed into the rejected (REJ) state as illustrated in Figure 21-3 on page 21-5. Once the card is in this state, then select 't' to accept the new card and provision the new capability as described earlier in this section.

If the customer has stayed within the same software base (the first two load digits have remained the same), then the card is now operational and running the new software release.

21.5.2 xpress upgrade option

New in the 6.1.4 software release is the **xpress** option. This option allows for downloading through the faceplate of the IPR*4 card using one of the four ethernet ports. This option provides a stream-lined method to upgrade. Using the existing tftp and xmodem options have their disadvantages. The xmodem option is very slow. The tftp option, though quick, must communicate to the CPU card installed and has limitations when activity is going on to the host CPU (such as telnet, pings, and other ethernet activity destined for the host CPU). Should a collision occur during the download, a 'dpram timeout' occurs, and depending on activity could prove insurmountable to the completion of the upgrade process. This express option allows for loading through the front of the IPR*4 card, but bypasses many of the statistics and updates that occur to and through the CPU. This option can only be used when the tftp server is connected to the IPR*4 card through the front of the IPR*4 card.

Once the download command has been chosen, select the **xpress** option, as seen in Figure 21-10. If the user decides to load a software image that the first two digits of the load do not match the currently running load (for example: x.y.zz - any load where 'x' and 'y' are not equal to the currently running load) then the card will change functionality and a reprovision of the card will be necessary.

```
Flash Screen | P3 IPR*4PPP Rev A0-0 Ser 10005 | 09-15-11 17:21
BLOCK NUMBER:      1
STATUS              actu
MODEL               IPR*4PPP
VERSION             1.1.0
I.D.                1
CHKSUM              0x11FD2012

Kernel 1.1, Checksum 0x11FD2012

Via:  xmodem  tftp  xpress
Copy | Refresh | Main
```

Figure 21-10.xpress download of IPR*4 card

Prior to beginning the download, the user will be prompted to confirm the location for the tftp server and the filename, as illustrated in Figure 21-11.

```
Flash Screen | P3 IPR*4PPP Rev A0-0 Ser 10005 | 09-15-11 17:23
BLOCK NUMBER:      1
STATUS             actv
MODEL              IPR*4PPP
VERSION            1.1.0
I.D.               1
CHKSUM             0x11FD2012

Kernel 1.1, Checksum 0x11FD2012

Download from IP: 172.16.73.213  Filename: ipr_2.0.00.bin <y/n>?
Copy | Refresh | Main
```

Figure 21-11.Download Confirmation

Caution should be exercised when confirming the download. Once the process begins, it cannot be stopped. Ensure that the tftp server is ready to receive the request, and that the IP address and file name are correct prior to confirming the action!

If the loadname selected will results in a functionality change, then the user will be prompted that they will need to reprovision services as noted in Figure 21-12.

```
Flash Screen | P1 IPR*4HDLCL Rev A0-0 Ser 00006 | 09-23-11 17:04
BLOCK NUMBER: 1 UPGRADE P1
STATUS Full
MODEL IPR*4HDLCL
VERSION 2.0.0
I.D. 1
CHKSUM 0x120C7C40

Kernel 2.0, Checksum 0x120C7C40

WARNING: This download will change the cardtype.
And you will lose all your provisioning.
Continue (y/n)?

Copy | Refresh | Main
```

Figure 21-12. Configuration change - reprovisioning needed

Once the user has confirmed the download, then the loading through the IPR*4 faceplate will commence as shown in Figure 21-13. An alarm indicating the loading process is raised, and the upgrade function starts locally on the card. Once the process completes, then the card will automatically reboot and the alarm will clear.

```
Flash Screen | P3 IPR*4PPPL Rev A0-0 Ser 10005 | 09-15-11 17:23
BLOCK NUMBER: 1 UPGRADE P3
STATUS actu
MODEL IPR*4PPPL
VERSION 1.1.0
I.D. 1
CHKSUM 0x11FD2012

Kernel 1.1, Checksum 0x11FD2012

Downloading ....
File transfer has started. Your screen will be locked
until the transfer has completed. This process may take
up to ten minutes to complete.
Copy | Refresh | Main
```

Figure 21-13. xpress download in Progress

WARNING! Once the card begins to write to flash, any disruption in this process could cause the card to become inoperable, and would require the card to be returned to Zhone for repair. DO NOT remove the card during this time! DO NOT attempt to change the status of the card! DO NOT drop power on the IMACS shelf!

Should the card now have new functionality (one of the first two load digits has changed), then the card will be placed into the rejected (REJ) state as illustrated in Figure 21-3 on page 21-5. Once the card is in this state, then select 't' to accept the new card and provision the new capability as described earlier in this section.

21.6 IPR*4 Card Alarm and Upgrade Events

A new log has been added for the IPR*4 card. An entry has been added for a Heart Beat (HB) fault. In the event of a heart beat failure, the card will be automatically restarted by the CPU.

```
23644 P3 IPR*4 I HB FAIL 08-25 13:30:41 08-25 13:30:41
```

A new alarm and log event has been added to the IPR*4 card. When the customer begins to download new software to the IPR*4 card, the system will raise an UPGRADE alarm. This alarm will note the server slot that is being upgraded. This alarm will clear once the download fails, or after the card reboots following a successful download.

Refer to Appendix B in the System Reference Guide for further information on Error Messages regarding this card.

21.7 IPR*4 Card Troubleshooting

On power-up, the IPR*4 card performs a self-test. This is the only diagnostic available for the IPR*4 card. A “healthy” active IPR will have a green LED lit on the front panel. The IPR*4 card can take a couple of minutes to come up in-service and active.

The indications that an IPR*4 is not on-line are:

- Continuous amber alarm LED on front panel AFTER the system has been registered during initial installation. (Prior to registration, the amber LED is an indication that registration needs to occur before the system can be fully operational).
- Inability to communicate with the system by any means (VT-100 Term, Telnet, etc.).
- The routing table is blank, even though a network device is connected.
- When accessing any of the card screens, the response “card not responding” indicates a failure on the IPR*4 card. Place the card OOS to restart the IPR*4.

Communications on the IPR*4 card can be observed by looking at the user screens provided. Should the IPR*4 card not be able to be seen, common things to look at are:

- Look at the main IPR*4 screen. Do you see the distant end IP address? Use the refresh function (r) to see updated information.
- Check the T1 connection. Is the T1/E1 up with no alarms?
- Look at the port side of the card, and check the status. Is the port that is needed in an UP state (use the r [refresh] key to see the state several times, as it is possible it is going up and down).
- As a last resort, OOS the card from the IMACS main screen to restart the IPR*4 card remotely.
- Call your next level of support.

If the IPR*4 card is determined to be faulty, replace it and return the faulty unit for repair to the location specified by your distributor.

IPR*4PPP Configuration

21.8 Introduction

The IPR*4 card provides a PPP backbone for customers to extend their communications, command and control capability in an IMACS network. This card extends the capability of the IMACS shelf to expand the range of control in the customers private network.

The IPR*4 card introduces the IMACS platform with the first PPP synchronous standard implementation of PPP, RFC 1661.

In order to provide the Ethernet to PPP inter-working capability, the IPR*4 10/100BT card has four modular RJ-45 interface jacks on the faceplate.

The software release level in the card determines the cards capabilities. The following illustrates the current and future direction of this card, and appropriate display names.

Table 21-3. IPR*4 PPP option

Card Display	Firmware	Faceplate Ethernet Jacks	Transport Links	High Speed Ports
IPR*4PPP	1.1.x	Individually Addressable	128 PPP	Yes, 4
IPR*4 PPP HS	1.2.x	Individually Addressable	8 PPP	Yes, 8
IPR*4HDLC	2.0.x	Individually Addressable	128 HDLC	Yes, 4

The IPR*4 10/100BT Cards are IP routers that route packets based on IP destination addresses. IPR*4 routes IP datagrams between Ethernet and PPP framed T1 or E1s.

IPR*4 will support SNMP for Ethernet, IP and Routing MIBs. It uses the standard Ethernet encapsulation, utilizing 14 bytes Ethernet Header: Source Ethernet Address (6 bytes), Destination Ethernet Address (6 bytes), and a Protocol Type (2 bytes). The IPR*4 card supports RIP (Routing Information Protocol, RFC 1058) as well as RIPv2, used for dynamically discovering IP routes from adjacent IP routers.

The WAN interface is standard encapsulation of IP datagrams over a PPP link.

The IMACS IPR*4 card does not support PPP authentication. The IPR*4 card is not designed to be a general purpose enterprise router, but rather is designed to extend the IMACS network of command and control applications contained within the customers T1/E1 network.

IPR*4 provides the capability to deliver IP packets to the CPU hosting the IPR*4. Assuming an average frame of 256 bytes, IPR*4 maintains LAN to WAN (and WAN to LAN) throughput of 2.048 Mbps.

21.9 IPR*4 configuration in a PPP Network

In the IPR*4 1.1.x release, the four ethernet ports are individually addressable and the card supports 128 PPP links. With 1.1.x loaded on the IPR*4 card, it displays IPR*4PPP.

21.9.1 IPR*4 Connecting IP LANs

The IPR*4 Card can be used for connecting IP LANs together through a PPP Network. Figure 21-2 shows a T1 PPP network between three Ethernet LANs.

Figure 21-14. IPR*4 Card Connected to IP LANs through a PPP Network

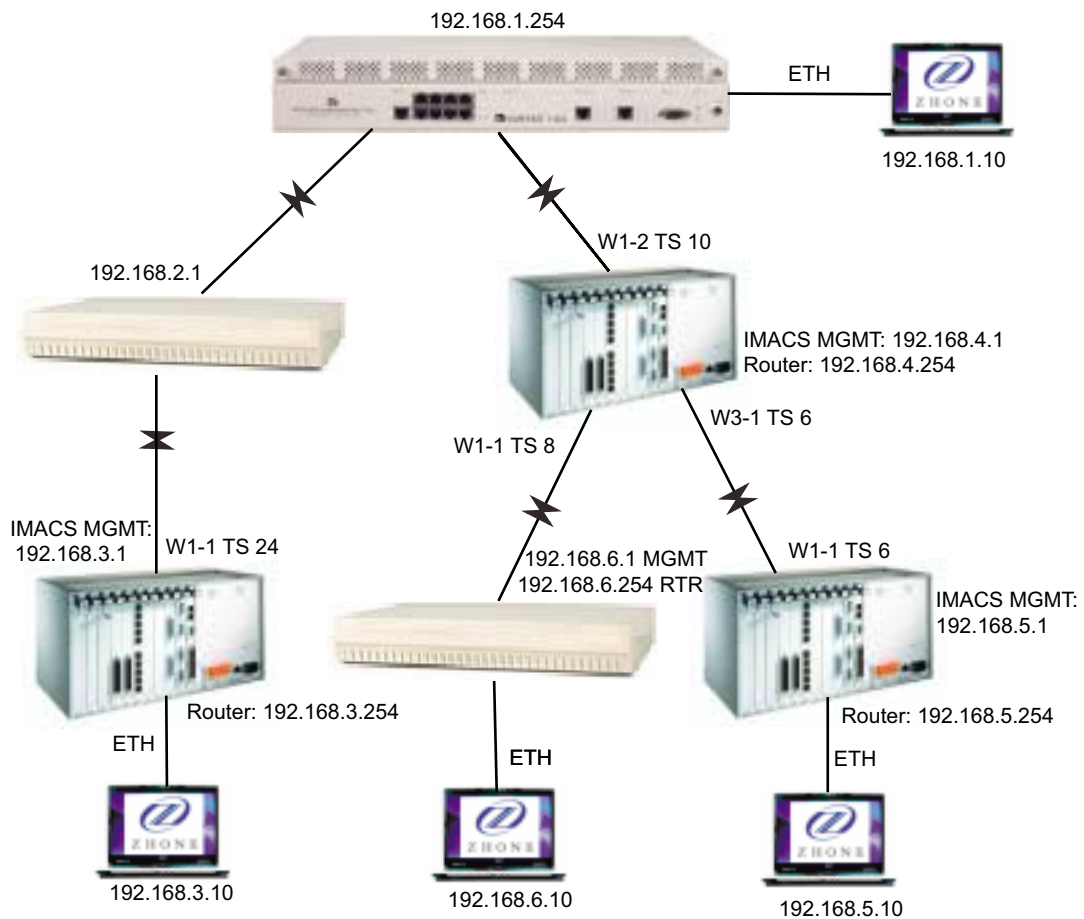

21.10 IPR*4PPP Configuration Screens and Settings

The IPR*4 card displays the four ethernet ports and their current status on the main login screen. The PPP link ports are not displayed at this level.

The IPR*4PPP card has 128 provisionable PPP WAN links available. Because of the interface to 128 T1 or E1 ports, the IPR*4PPP cards take about a minute to initialize on power-up and restarts. Some system interactions take longer than other cards when dealing with the IPR*4PPP card such as in the case of accepting the card from a rejected (REJ) state. This action will cause the user interface (UI) updates to cease as the IMACS provisions and establishes the 128 WAN link configuration. The IMACS continues to operate during this time, however the UI cannot be updated until the task completes.

The system can be configured in such a way as to allow the IMACS management port to come over the PPP link. Figure 21-4 on page 21-6 shows the setup to manage this IMACS node through the IPR*4 card. The default IP port noted in the figure is pointed to the IPR*4 server card, which in this example resides in slot P1. Please note that when managing the IMACS through the IPR*4 card, a change to the IMACS host CPU IP address may require that the IPR*4 card be restarted (placed OOS) in order for the new IMACS IP address to be accessible.

21.10.1 IPR*4 10/100BT (883270) Card Main Screen

The main screen of the IPR*4 screen gives the operator the current interface setup of the card by displaying the current routing table for the card. This main screen is shown in Figure 21-5.

```

ZhoneIMACS | P1 IPR*4PPP Rev A0-0 Ser 10008 | 02-16-12 10:43
Version #:1.1.1
                IP Router Routing Table

#      Route          Dist      Next Hop      Interface      Status      S
1  13.13.13.0         1      13.13.13.13   NODE13         D....      G
2  192.168.1.0        1      192.168.1.12  GOVMNT         D....      G
3  192.168.5.0        1      192.168.5.1   CENTRAL        D....      G
4  192.168.10.0       1      192.168.10.1  REMOTE         D....      G
5  172.16.73.13       1      13.13.13.13   HOST RT        .H...      G
6  192.168.15.0       1      192.168.5.1   CENTRAL        .S...      G
7  23.23.23.0         1      13.13.13.13   DOWNTN         D....      G
8  172.16.73.23       2      23.23.23.23   DOWNTN         ....R      G

                Total # Of IP Routes : 8

STATUS :   D=DIRECT   S=STATIC   H=HOST   F=DEFAULT   R=RIP
S(STATE): G = GOOD    P = SUSPECT B = BAD

Refresh | pgUp | pgDn | eNet | Stat | port | Intf name | Ping | Main

```

Figure 21-15. IPR*4 10/100BT Card Interface Main Screen

The default IPR*4 screen shows the current software level of the IPR*4 card, as well as all the routes visible to the IPR*4 card. The Interface column displays the interface name as assigned either in the **INTF NAME** window or from PPP discovery messages. In addition it displays the way that this information was obtained, either by rip or static entries. Finally, the display indicates if the route is good, bad, or suspect. A **GOOD** route is one that has recently been updated. A **SUSPECT** route is one that the system has not had a RIP update for 90 seconds. A **BAD** route is one that has passed the suspect stage, and is declared **BAD** after the lapse of an additional 30 seconds. Once a **BAD** route has existed for an additional 30 seconds, it will be deleted from the routing table.

Table 21-4. IPR*4 10/100BT Card Main Screen Actions

Action	Function
Refresh	Refresh the current screen.
PgUP	Scrolls up one page.
PgDn	Scrolls down one page.
eNet	Go to Ethernet and Default IP screen.
Stat	Go to Static Route configuration screen.
Port	Go to the PPP Port provisioning screen.
Intf name	Define the Interface name and associate it to an IP address
Ping	Allows for sending a ping out from the IPR*4 card
Main	Go back to the IP Interface Main Menu Screen.

The 1.x.y software release of the IPR*4 card is a PPP interface device. In this software stream, the four RJ-45 ethernet jacks are independently addressable, and the card can interface with up to 128 PPP WAN links. In order to provision and control the interfaces, the use of the settings on the IPR*4 main screen need to be defined. As shown in Table Table 21-2 and figure Figure 21-5, these parameters are **eNet**, **Stat**, **porT** and **INTF NAME**. For the PPP WAN link interface, the **INTF NAME** screen is not used as discovery messages on the PPP link will associate an IP address to the link.

21.10.2 IPR*4 provisioning card setup

The basic premise of the IPR*4 card is to connect IP addressable entities from the four provided RJ-45 ethernet jacks on the faceplate of the card to a remote management system over T1 or E1 WAN links. For this purpose, the setup of the card takes place in two venues: the ethernet side (**eNet**) and in the T1 or E1 port (**porT**) side. Connectivity occurs due to the IPR*4 card being able to associate IP addresses via RIP, RIPv2, static provisioning, PPP discovery, etc. from the faceplate of the card to the appropriate WAN PPP link. The ethernet side always requires that the user describe this interface in the **INTF NAME** screen. This associates an IP address to a ethernet jack on the faceplate of the card.

On the T1/E1 side, the PPP interface discovers the far-end IP address through IPCP discovery messaging, and therefore an IP address association is made through the PPP protocol. Due to this automatic association, an entry in the **INTF NAME** screen is not needed. To give the user a recognizable entity that can be found, the IPR*4 provides a name to be assigned on the PPP **porT** screen.

The card provisioning setup for the PPP interface is summarized below.

11. Add IP addresses to name associations in the **INTF NAME** screen for the four ethernet jacks on the router card.
12. Use the ethernet screen (**eNet**) to turn up in-service and provision the four ethernet jacks. The name entered in step one is required to turn up the four ethernet jacks.

13. Go to the **porT** screen, and assign the WAN connections to the remote systems. The IP address that exists at the far-end of the PPP link will be automatically discovered through IPCP messaging. You will need to enter a name on the **porT** screen to help locate the appropriate link later using the **Find** command functions.
14. Turn-up the **porT**, and the status should change to UP if all provisioning and WAN links are in the appropriate state and provisioned correctly.

21.10.3 IPR*4 INTF NAME screen

The **INTF NAME** screen is where associations are defined between an IP address and the ethernet jacks on the front of the card. This interface should **not** be used to define the PPP links; this association will be added on the **porT** screen itself. The **INTF NAME** screen is shown in Figure 21-16

```
ZhoneIMACS | P1 IPR*4PPP Rev A0-0 Ser 10008 | 02-16-12 09:54
page: 1 of 1      IP ROUTER INTERFACE MENU
NAME           IP ADDR           IP MASK
NODE13        13.13.13.13      255.255.255.0
GOVMNT        192.168.1.12     255.255.255.0
CENTRAL       192.168.5.1      255.255.255.0
REMOTE        192.168.10.1     255.255.255.0

Ref | Add | dEl | pgUp | pgDn | Find | find Next | Main
```

Figure 21-16.INTF Name Screen

Table 21-5. IPR*4 Interface Name Screen Action

Action	Function
Ref	Refresh the current screen.
Add	Adds a new Interface name
dEl	Deletes the currently selected Interface name if not in use.
PgUP	Scrolls up one page.
PgDn	Scrolls down one page.
Find	Searches to find an interface name
find Next	When searching for a name, uses the same Find parameters but locates the next occurrence in the Interface name table.
Main	Go back to the IP Interface Main Menu Screen.

Add

The add command allows the user to add a new ethernet port interface name and IP address association, or a new HDLC port IP address and name association. PPP IP address associations should not be added here.

Del

Del allows the user to delete the IP address to name association, as long as that association is not in use.

Find

Provides the user the ability to find a particular string in a name. For example, if the user knew that the string ATL was in use then the user could use the find function and search for the string "ATL". Similarly, the user could search simply for "A".

Find next

The find next command allows the system to scroll to the next occurrence of the string entered in the Find command. With 128 addressable ports, this is a useful function to locate end points through potentially several pages of entries without having to use the page up and down functions.

21.10.4 IPR*4 Ethernet Connectivity Screen

Once the interface name and associated address has been described, then the individual jacks on the ethernet side can be setup. The IPR*4 card has four ethernet RJ-45 jacks, and these are individually addressable. The eNet screen is shown in Figure 21-17. This screen will display all four ethernet jacks available on the faceplate of the card. Depending on the card software

release in use, some of the field actions (such as State, Interface name and/or Default gateway) will update all four jacks. The system will prompt to apply the change to all the affected jacks when the change taking place affects all four jacks.

ZhongMACS P1 IPR*4PPP Rev A0-0 Ser 10008 02-16-12 09:59					
	1	2	3	4	
STATE	actv	actv	actv	actv	
DEFAULT GATEWAY	ip	ip	ip	ip	
INTERFACE NAME	NODE13	GOVMNT	CENTRAL	REMOTE	
SPEED	auto	100	auto	10	
DUPLEX	half	full	half	full	
IP MTU	1500	1500	1500	1500	
RIP Rx	on	off	on	on	
RIP Tx	v2	v2	v1	off	
SH	yes	yes	yes	yes	

Save | Undo | Refresh | Perf | Arp | Main

Figure 21-17. Ethernet screen for IPR*4 card

The IPR*4 card uses ethernet jack 1 as the base address for the router card. The first ethernet jack interface must have an IP address assigned to it, and be active. **Changing the status of the first ethernet jack will result in a card restart.** This restart is required to allow for proper handling of messages to and from the card. The system will prompt when placing the first ethernet jack into a standby or active status that the card will perform a restart. This restart is executed automatically by the system once the jack is made active, and the change is saved. The other three jacks - numbered 2 through 4 - do not have this constraint, and can be removed and placed back in service without the need to reset the entire card.

Table 21-6. IPR*4 10/100BT Ethernet Menu Option Settings and Defaults

Parameter	User Options	Default
STATE	actv stdby	stdby
DEFAULT GATEWAY	IP address - 0.0.0.0	0.0.0.0
INTERFACE NAME	user selectable	none
SPEED	10 100 auto	auto
DUPLEX	half full	half
IP MTU	1500	1500
RIP Rx	off on	on
RIP Tx	off v1 v2	v2
SH	yes no	yes

State

Activates or deactivates Ethernet jack. The settings are **actv** or **stdby**. Placing jack 1 into a **stdby** state will result in the restart of the IPR*4 card once it is placed back into the **actv** state.

Default Gateway

The default gateway is used to set the default route that unknown packets should be sent. The gateway will be common for all four ethernet jacks. The default gateway must be a reachable address, on the same subnet as the router card. **Changing the default gateway to an in-service card will require a card restart.** This restart is executed by the system once a change to this field is saved. If the default gateway is not immediately accessible, then the default gateway should remain at 0.0.0.0.

Interface name

The interface name is used to define the IP interface, as set by the **INTF NAME** screen from the IPR*4 main screen. The four jacks must be set to four independent IP subnets.

Speed

The default for the jacks is **auto**, but they can be set independently to **10BT** or **100BT**.

Duplex

The default for the jacks is **half**, but they can be set independently to **full**.

IP MTU

The only current option is 1500.

RIP Rx

Set each jack to turn RIP receive **on** or **off**, the default is **on**. This option can be disabled by setting it to **off**. The following are internally set defaults for RIP, they cannot be changed:

- a) Update Interval: 30 seconds
- b) Invalid: 90 seconds
- c) Hold Down: 30 seconds
- d) Garbage: 240 seconds

RIP Tx

Set each jack to transmit RIP packets in **v1** or **v2** mode - or turn it **off**. **v2** is the default.

SH

Enables or disables split horizon on Ethernet. Options are **yes** or **no**. Split-horizon route advertisement is a method of preventing routing loops in distance-vector routing protocols (such as RIP) by prohibiting a router from advertising a route back onto the interface from which it was learned.

21.10.4.1 IPR*4 Ethernet Connectivity Screen - Perf

The IPR*4 ethernet connectivity screen allows the user to look at packet statistics provided by the system. Figure 21-18 shows data displayed by entering this option.

```

ZhoneIMACS | P1 IPR*4PPP Rev A0-0 Ser 00006 | 02-13-12 17:29
IP Router Ethernet Port Statistics
ETHERNET ADDR          00.a0.1b.54.00.07
PACKETS RX:            20630
PACKETS TX:            61305
RX ERRORS:              174
TX ERRORS:              0
BROADCASTS RX:         48
MULTICASTS RX:         182

Refresh | Clear | Main

```

Figure 21-18. IPR*4 Ethernet Performance Screen

21.10.4.2 IPR*4 Ethernet Connectivity Screen - ARP

The ARP screen will display when pressing the “**A**” (**Arp**) from the Ethernet screen. shows the ARP Table screen. This screen will display ARP Entries, Ethernet Addresses, and the State in which each ARP entry (e.g GOOD, BAD, etc.). Figure 21-19 shows an ARP table gathered on a working system.

The ARP screen will display when pressing the “A” (**Arp**) from the Ethernet screen. Figure 21-19 shows the ARP Table screen. This screen will display ARP Entries, Ethernet Addresses, and the State in which each ARP entry (e.g GOOD, BAD, etc.).

```

Simul_C_CB1 | P1 IPR*4PPP Rev A0-0 Ser 00006 | 08-31-11 13:22
IP Router ARP TABLE
#      Arp Entry      Eth. Address      State
1  172.16.73.254    40.55.39.ac.51.4a  GOOD
2  172.16.73.213    00.b0.d0.84.3f.48  GOOD

Total # Of ARP Entries : 2
Inverse ARP Received : 0   Inverse ARP Replied : 0

Refresh | PgUp | PgDn | Clear | Main

```

Figure 21-19.IPR*4 10/100BT ARP Table Screen

21.10.5 IPR*4 Port Screen

Once the ethernet side of the IPR*4 card has been setup, then the PPP T1/E1 WAN link side can be setup using the **porT** option from the IPR*4 anchor window. The card can support up to 128 links, with the first four of these links having the ability to handle higher bandwidth. Ports one through four can be assigned up to an entire T1 or E1 worth of bandwidth per port. When using multiple DS0 timeslots on the first four ports, the selected DS0 ports must be contiguous. The port interface for the IPR*4PPP shown in Figure 21-20.

ZhongIMACS P1 IPR*4PPP Rev A0-0 Ser 10008 02-16-12 10:27				
	1	2	3	4
STATE	actv	actv	stdby	stdby
INTF NAME	DOWNTN	UPTN		
WAN	w4-1	w3-1	none	none
TS	table	table	table	table
PROTOCOL	ppp	ppp	ppp	ppp
RIP Rx	on	on	on	on
RIP Tx	v2	v2	v2	v2
SH	yes	yes	yes	yes
LINK ST	UP	UP	DOWN	DOWN

Save | Undo | Refresh | Copy | < | > | porT | Find | find Next | Perf

Figure 21-20. IPR*4PPP Port Display

When defining the ports for the PPP interface, the IP address is determined through the use of IPCP discovery messages when the T1/E1 WAN link is coming up in-service. Since the IP address is determined by the link itself, the **porT** provisioning provides a descriptive field called INTF NAME for the customer to name the particular T1/E1 interface. This allows for a descriptive and meaningful identifier to be associated with the WAN link interface in order to be found later using the **Find** and **find Next** functions.

Table 21-7. IPR*4 Port Menu Option Settings and Defaults

Action	Function
Save	actv stdby
Undo	Removes any items marked to be saved.
Refresh	Refresh the current screen.
Copy	Copies the data on the given port to the next port.
<	Scroll down to the previous four PPP ports
>	Scroll up to the next four PPP ports
porT	Access the information for a given port number
Find	Searches to find an interface name
find Next	When searching for a name, uses the same Find parameters but locates the next occurrence in the Interface name table.
Main	Go back to the IPR*4 Interface Main Screen.

Find

Provides the user the ability to find a particular string in a name. For example, if the user knew that the string ATL was in use then the user could use the find function and search for the string “ATL”. Similarly, the user could search simply for “A”.

Find next

The find next command allows the system to scroll to the next occurrence of the string entered in the Find command. With 128 addressable ports, this is a useful function to locate end points through potentially several pages of entries without having to use the page up and down (< and >, respectively) functions.

Table 21-8. IPR*4 10/100BT port Menu Option Settings and Defaults

Parameter	User Options	Default
STATE	actv stbby	stdby
INTF NAME	Unique 7-character string to identify the far end.	blank
WAN	none w1-1 w1-2 w2-1 w2-2 w3-1 w3-2 w4-1 w4-2	none
TS	1-32	1-32
PROTOCOL	ppp	ppp
RIP Rx	off on	on
RIP Tx	off v1 v2	v2
SH	yes no	yes
LINK ST	Display Only n/a UP or DOWN	n/a

State

Activates or deactivates the PPP port. The settings are **actv** or **stdby**.

INTF NAME

Enter a seven character string to identify the remote end of the link. This name is entered to assist the customer by naming the port. The actual IP address in the PPP application is discovered on the link itself. Once the link reaches the UP status with the remote end, pressing carriage return on this field will reveal the IP address and netmask of the remote end.

WAN

This field points to the WAN slot to carry the PPP WAN link. Options are **wan** (w1-1 through w4-2).

TS

Ports 1 through 4 can be set for any number of contiguous timeslots, up to 24 for T1 (DSX) WAN and 32 for E1 (CEPT) WAN. For ports 5 through 128, these can set for a single DS0 only.

PROTOCOL

Display only, set for PPP.

RIP Rx

Set each port to turn RIP receive **on** or **off**, the default is **on**. This option can be disabled by setting it to **off**. The following are internally set defaults for RIP, they cannot be changed:

- a) Update Interval: 30 seconds
- b) Invalid: 90 seconds
- c) Hold Down: 30 seconds
- d) Garbage: 240 seconds

RIP Tx

Set each port to transmit RIP packets in **v1** or **v2** mode - or turn it **off**. **v2** is the default.

SH

Enables or disables split horizon on Ethernet. Options are **yes** or **no**. Split-horizon route advertisement is a method of preventing routing loops in distance-vector routing protocols (such as RIP) by prohibiting a router from advertising a route back onto the interface from which it was learned.

LINK ST

This display-only field shows the state of the LCP (Link Communications Protocol) internal status. In order for PPP to properly initialize, the LCP negotiation between the near end and far end must complete, and display an **UP** value. A DS1 circuit that is in-service at both ends, will not be able to carry PPP traffic if the LCP link status is **DOWN**. If there is no provisioning, or there is a communication issue to the IPR*4 card, then the default of **n/a** is displayed.

21.10.6 IPR*4 Static Route Screen

```

ZhoneIMACS | P1 IPR*4PPP Rev A0-0 Ser 10008 | 02-16-12 10:10
page: 1 of 1      IP Router STATIC MENU
IP Net          Subnet          GoTo          Dist
192.168.15.15  255.255.255.0  192.168.5.1  1
Refresh | Add | dElete | pgUp | pgDn | Main

```

Figure 21-21. IPR*4 Static Route Entry

Table 21-9. IPR*4 10/100BT IP Static Routes Configuration Table Screen Actions

Action	Function
Refresh	Refreshes the current screen
Add	Adds the selected information on the screen (e.g. IP net, Subnet, etc.)
dElete	Deletes the selected information from the screen
pgUp	Scrolls up through the list of IP static routes
pgDn	Scrolls down through the list of IP static routes
Main	Returns to the IP Interface Menu screen

When adding a static route, the following input is required:

IP NET

A destination IP network address. Enter a valid IP address (e.g. 125.15.0.0).

SUBNET

A subnet mask. Enter a valid subnet mask (e.g. 255.255.0.0).

GOTO

IP address of the next IP gateway for this static route. Enter a valid IP address gateway (e.g. 192.168.1.254).

DIST

Administrative distance (in hops) for this static route.



Note: *The static routes will always be preferred to dynamic routes regardless of the Distance. This Distance will, however, be advertised in any routing updates for this static route.*

IPR*4 HDLC Configuration

21.11 Introduction

The IPR*4 card provides a HDLC backbone for customers to extend their communications, command and control capability in an IMACS network. This card extends the capability of the IMACS shelf to expand the range of control in the customers private network.

In order to provide the Ethernet to HDLC inter-working capability, the IPR*4 10/100BT card has four modular RJ-45 interface jacks on the faceplate.

The software release level in the card determines the cards capabilities. The following illustrates the current and future direction of this card, and appropriate display names.

Table 21-10. IPR*4 available options

Card Display	Firmware	Faceplate Ethernet Ports	Transport Links	High Speed Ports
IPR*4PPP	1.1.x	Individually Addressable	128 PPP	Yes, 4
IPR*4 PPP HS	1.2.x	Individually Addressable	8 PPP	Yes, 8
IPR*4HDLC	2.0.x	Individually Addressable	128 HDLC	Yes, 4

The IPR*4 10/100BT Cards are IP routers that route packets based on IP destination addresses. IPR*4 routes IP datagrams between Ethernet and HDLC framed T1 or E1s.

IPR*4 will support SNMP for Ethernet, IP and Routing MIBs. It uses the standard Ethernet encapsulation, utilizing 14 bytes Ethernet Header: Source Ethernet Address (6 bytes), Destination Ethernet Address (6 bytes), and a Protocol Type (2 bytes). The IPR*4 card supports RIP (Routing Information Protocol, RFC 1058) as well as RIPv2, used for dynamically discovering IP routes from adjacent IP routers.

The WAN interface is standard encapsulation of IP datagrams over a HDLC link.

The IPR*4 card is not designed to be a general purpose enterprise router, but rather is designed to extend the IMACS network of command and control applications contained within the customers T1/E1 network.

IPR*4 provides the capability to deliver IP packets to the CPU hosting the IPR*4. Assuming an average frame of 256 bytes, IPR*4 maintains LAN to WAN (and WAN to LAN) throughput of 2.048 Mbps.

Management to the IMACS-200 is supported with the HDLC firmware.

21.12 IPR*4 configuration in a HDLC Network

In the IPR*4 2.0.x release, the four ethernet jacks are individually addressable and the card supports 128 HDLC links. With 2.0.x loaded on the IPR*4 card, it displays IPR*4HDLC.

21.12.1 IPR*4 Connecting IP LANs

The IPR*4 Card can be used for connecting IP LANs together through a HDLC Network.

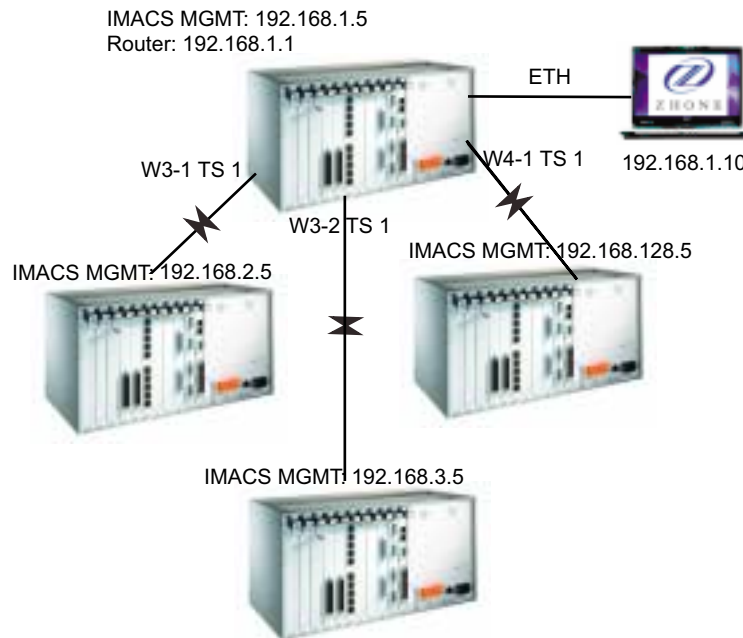

Figure 21-22. IPR*4HDLC IMACS node Management

For simplicity, the IMACS diagram illustrates the HDLC management links being dispersed over different WANS. Use of a DACS or similar T1/E1 grooming device would allow for each DS0 to be sent to different destinations. Also for simplicity, only one ethernet device is shown connected to the four available ethernet jacks.

21.13 IPR*4HDLC Configuration Screens and Settings

The IPR*4 card displays the four ethernet jacks and their current status on the main login screen. The HDLC link ports are not displayed at this level.

The IPR*4HDLC card has 128 provisionable HDLC WAN links available. Because of the interface to 128 T1 or E1 ports, the IPR*4HDLC card takes about a minute to initialize on power-up and restarts. Some system interactions take longer than other server cards such as in the case of accepting the card from a rejected (REJ) state. This action causes the user interface (UI) updates to cease as the IMACS provisions and establishes the 128 WAN link configuration. The IMACS continues to operate during this time, however the UI is not updated until the provisioning task completes.

The system can be configured in such a way as to allow the IMACS management port to come over the HDLC link. Figure 21-4 on page 21-6 shows the setup to manage this IMACS node through the IPR*4 card. The default IP port noted in the figure is pointed to the IPR*4 server card, which in this example resides in slot P1. Please note that when managing the IMACS through the IPR*4 card, a change to the IMACS host CPU IP address may require that the IPR*4 card be restarted (placed OOS) in order for the new IMACS IP address to be accessible.

21.13.1 IPR*4 10/100BT (883270) Card Main Screen

The main screen of the IPR*4 screen gives the operator the current interface setup of the card by displaying the current routing table for the card. This main screen is shown in Figure 21-5.

```

ZhoneIMACS | P1 IPR*4HDLC Rev A0-0 Ser 00006 | 02-13-12 16:23
Version #:2.0.0
                IP Router Routing Table

#      Route          Dist      Next Hop          Interface  Status  S
1  172.16.73.0        1      172.16.73.84      IPR_INC   D..F..  G
2  172.16.73.83       1      172.16.73.84      HOST RT   ..H..   G
3  172.16.93.0        1      172.16.93.93      93        D....   G
4  172.16.170.0       1      172.16.170.170    170       D....   G
5  172.16.109.0       1      172.16.109.109    109       D....   G
6  172.16.128.0       1      172.16.128.128    128       D....   G
7  172.16.129.0       1      172.16.129.129    129       D....   G
8  172.16.111.0       1      172.16.111.111    111       D....   G
9  172.16.55.0        1      172.16.55.55      55        D....   G
10 172.16.46.0        1      172.16.46.46      46        D....   G

                Total # Of IP Routes : 10

STATUS  :   D=DIRECT   S=STATIC   H=HOST     F=DEFAULT   R=RIP
S(STATE):   G = GOOD   P = SUSPECT B = BAD

Refresh | pgUp | pgDn | eNet | Stat | porT | Intf name | Ping | Main
    
```

Figure 21-23.IPR*4HDLC 10/100BT Card Interface Main Screen

The default IPR*4 screen shows the current software level of the IPR*4 card, as well as all the routes visible to the IPR*4 card. The Interface column displays the interface name as assigned in the **INTF NAME** window. In addition it displays the way that this information was obtained, either by rip or static entries. Finally, the display indicates if the route is good, bad, or suspect. A GOOD route is one that has recently been updated. A SUSPECT route is one that the system has not had a RIP update for 90 seconds. A BAD route is one that has passed the suspect stage, and is declared BAD after the lapse of an additional 30 seconds. Once a BAD route has existed for an additional 30 seconds, it will be deleted from the routing table.

Table 21-11. IPR*4 10/100BT Card Main Screen Actions

Action	Function
Refresh	Refresh the current screen.
PgUP	Scrolls up one page.
PgDn	Scrolls down one page.
eNet	Go to Ethernet and Default IP screen.
Stat	Go to Static Route configuration screen.
Port	Go to the PPP Port provisioning screen.
Intf name	Define the Interface name and associate it to an IP address
Ping	Allows for sending a ping out from the IPR*4 card
Main	Go back to the IP Interface Main Menu Screen.

The 2.x.y software release of the IPR*4 card is a HDLC interface device. In this software stream, these four ethernet jacks are independently addressable, and the card can interface with up to 128 HDLC links. In order to provision and control the interfaces, the use of the settings on the IPR*4 main screen need to be defined. As shown in Table Table 21-2 and figure Figure 21-5, these parameters are **eNet**, **Stat**, **porT** and **INTF NAME**.

21.13.2 IPR*4 provisioning card setup

The basic premise of the IPR*4 card is to connect IP addressable entities from the four provided RJ-45 ethernet jacks on the faceplate of the card to a remote management system over T1 or E1 WAN links. For this purpose, the setup of the card takes place in two venues: the ethernet side (**eNet**) and in the T1 or E1 port (**porT**) side. Connectivity occurs due to the IPR*4 card being able to associate IP addresses via RIP, RIPv2, static provisioning, etc. from the faceplate of the card to the appropriate WAN HDLC link. The ethernet side always requires that the user describe this interface in the **INTF NAME** screen. This associates an IP address to a ethernet jack on the faceplate of the card.

On the T1/E1 side, the HDLC interface is also provisioned on the **INTF NAME** screen.

The card provisioning setup for the HDLC interface is summarized below.

1. Add IP address to name associations in the **INTF NAME** screen for the four ethernet jacks on the router card.
2. Add IP address to name associations in the **INTF NAME** screen for up to 128 HDLC WAN link connections.
3. Use the ethernet screen (**eNet**) to turn up in-service and provision the four ethernet jacks. The name in step one is required to turn up the ethernet jacks.
4. Go to the **porT** screen, and assign the WAN connections to the remote systems. You will need to enter the appropriate interface name on the **porT** screen as defined in step 2 above.

5. Turn-up the **porT**, and the status should change to UP if all provisioning and WAN links are in the appropriate state and provisioned correctly.

21.13.3 IPR*4 INTF NAME screen

The **INTF NAME** screen is where associations are defined between an IP address and the ethernet jacks on the front of the card. This interface is also used to define the HDLC link names with PI addresses. The **INTF NAME** screen is shown in Figure 21-17.

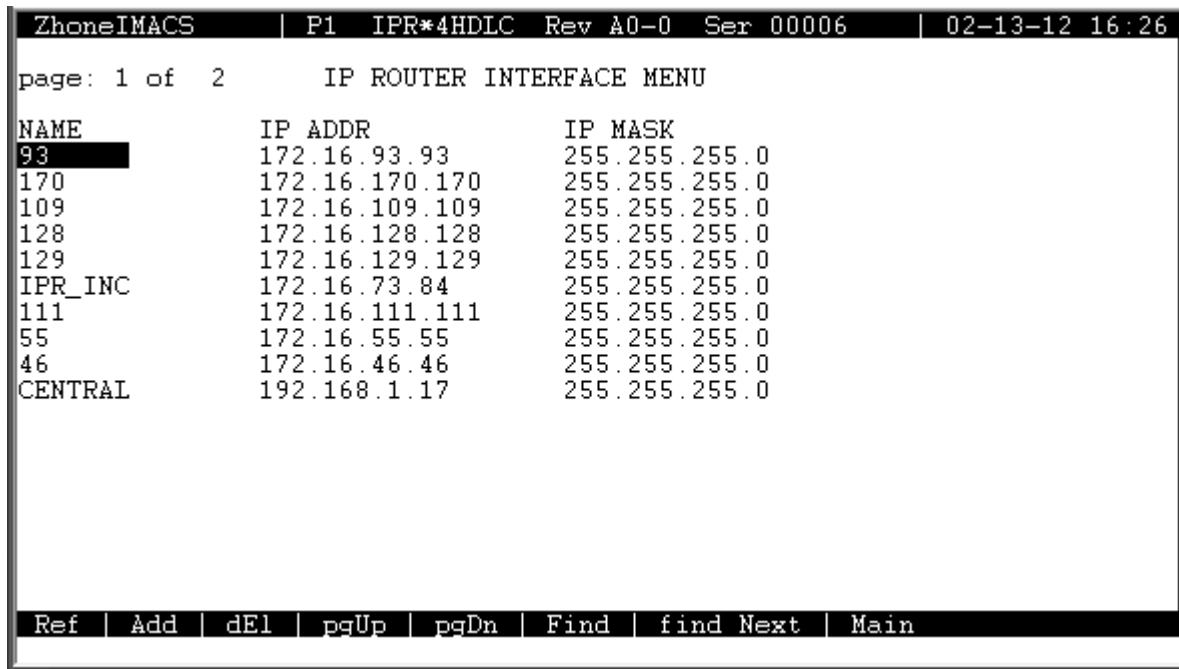

```
ZhoneIMACS | P1 IPR*4HDLC Rev A0-0 Ser 00006 | 02-13-12 16:26
page: 1 of 2      IP ROUTER INTERFACE MENU
NAME            IP ADDR        IP MASK
93              172.16.93.93   255.255.255.0
170             172.16.170.170 255.255.255.0
109             172.16.109.109 255.255.255.0
128             172.16.128.128 255.255.255.0
129             172.16.129.129 255.255.255.0
IPR_INC         172.16.73.84   255.255.255.0
111             172.16.111.111 255.255.255.0
55              172.16.55.55   255.255.255.0
46              172.16.46.46   255.255.255.0
CENTRAL         192.168.1.17   255.255.255.0

Ref | Add | dEl | pgUp | pgDn | Find | find Next | Main
```

Figure 21-24.INTF Name Screen

Table 21-12. IPR*4 Interface Name Screen Action

Action	Function
Ref	Refresh the current screen.
Add	Adds a new Interface name
dEl	Deletes the currently selected Interface name if not in use.
PgUP	Scrolls up one page.
PgDn	Scrolls down one page.
Find	Searches to find an interface name
find Next	When searching for a name, uses the same Find parameters but locates the next occurrence in the Interface name table.
Main	Go back to the IP Interface Main Menu Screen.

Add

The add command allows the user to add a new ethernet port interface name and IP address association, or a new HDLC port IP address and name association. PPP IP address associations should not be added here.

Del

Del allows the user to delete the IP address to name association, as long as that association is not in use.

Find

Provides the user the ability to find a particular string in a name. For example, if the user knew that the string ATL was in use then the user could use the find function and search for the string "ATL". Similarly, the user could search simply for "A".

Find next

The find next command allows the system to scroll to the next occurrence of the string entered in the Find command. With 128 addressable ports, this is a useful function to locate end points through potentially several pages of entries without having to use the page up and down functions.

21.13.4 IPR*4 Ethernet Connectivity Screen

Once the interface name and associated address has been described, then the individual jacks on the ethernet side can be setup. The IPR*4 card has four ethernet RJ-45 jacks, and these are individually addressable ethernet jacks. The eNet screen is shown in Figure 21-17. This screen will display all four ethernet jacks available on the faceplate of the card. Depending on the

card software release in use, some of the field actions (such as State, Interface name and/or Default gateway) will update all four ports. The system will prompt to apply the change to all the affected ports when the change taking place affects all four jacks.



Figure 21-25. Ethernet screen for IPR*4 card

The IPR*4 card uses ethernet port 1 as the base address for the router card. The first ethernet jack interface must have an IP address assigned to it, and be active. **Changing the status of the first ethernet jack will result in a card restart.** This restart is required to allow for proper handling of messages to and from the card. The system will prompt when placing the first ethernet jack into a standby or active status that the card will perform a restart. This restart is executed automatically by the system once the port is made active, and the change is saved. The other three jacks - numbered 2 through 4 - do not have this constraint, and can be removed and placed back in service without the need to reset the entire card.

Table 21-13. IPR*4 10/100BT Ethernet Menu Option Settings and Defaults

Parameter	User Options	Default
STATE	actv stdby	stdby
DEFAULT GATEWAY	IP address - 0.0.0.0	0.0.0.0
INTERFACE NAME	user selectable	none
SPEED	10 100 auto	auto
DUPLEX	half full	half
IP MTU	1500	1500
RIP Rx	off on	on
RIP Tx	off v1 v2	v2
SH	yes no	yes

State

Activates or deactivates Ethernet jack. The settings are **actv** or **stdby**. Placing jack 1 into a **stdby** state will result in the restart of the IPR*4 card once it is placed back into the **actv** state.

Default Gateway

The default gateway is used to set the default route that unknown packets should be sent. The gateway will be common for all four ethernet jacks. The default gateway must be a reachable address, on the same subnet as the route card. **Changing the default gateway to an in-service card will require a card restart.** This restart is executed by the system once a change to this field is saved. If the default gateway is not immediately accessible, then the default gateway should remain at 0.0.0.0.

Interface name

The interface name is used to define the IP interface, as set by the **INTF NAME** screen from the IPR*4 main screen. The four jacks must be set to four independent IP subnets.

Speed

The default for the jacks is **auto**, but they can be set independently to **10BT** or **100BT**.

Duplex

The default for the jacks is **half**, but they can be set independently to **full**.

IP MTU

The only current option is 1500.

RIP Rx

Set each jack to turn RIP receive **on** or **off**, the default is **on**. This option can be disabled by setting it to **off**. The following are internally set defaults for RIP, they cannot be changed:

- a) Update Interval: 30 seconds
- b) Invalid: 90 seconds
- c) Hold Down: 30 seconds
- d) Garbage: 240 seconds

RIP Tx

Set each jack to transmit RIP packets in **v1** or **v2** mode - or turn it **off**. **v2** is the default.

SH

Enables or disables split horizon on Ethernet. Options are **yes** or **no**. Split-horizon route advertisement is a method of preventing routing loops in distance-vector routing protocols (such as RIP) by prohibiting a router from advertising a route back onto the interface from which it was learned.

21.13.4.1 IPR*4 Ethernet Connectivity Screen - Perf

The IPR*4 ethernet connectivity screen allows the user to look at packet statistics provided by the system. Figure 21-18 shows data displayed by entering this option.

```

ZhoneIMACS | P1 IPR*4HDLC Rev A0-0 Ser 00006 | 02-13-12 17:29
IP Router Ethernet Port Statistics
ETHERNET ADDR          00.a0.1b.54.00.07
PACKETS RX:            20630
PACKETS TX:            61305
RX ERRORS:             174
TX ERRORS:             0
BROADCASTS RX         48
MULTICASTS RX:        182
Refresh | Clear | Main

```

Figure 21-26. IPR*4 Ethernet Performance Screen

21.13.4.2 IPR*4 Ethernet Connectivity Screen - ARP

The ARP screen will display when pressing the “**A**” (**Arp**) from the Ethernet screen. shows the ARP Table screen. This screen will display ARP Entries, Ethernet Addresses, and the State in which each ARP entry (e.g GOOD, BAD, etc.). Figure 21-19 shows an ARP table gathered on a working system.

```
ZhoneIMACS | P1 IPR*4HDLC Rev A0-0 Ser 00006 | 02-13-12 17:27
IP Router ARP TABLE
#      Arp Entry      Eth. Address      State
1  172.16.73.254     40.55.39.ac.51.4a  GOOD
2  172.16.73.180     00.b0.d0.7d.bd.82  GOOD
3  172.16.73.150     00.03.ba.1f.88.ab  GOOD

Total # Of ARP Entries : 3
Inverse ARP Received : 0      Inverse ARP Replied : 0
Refresh | PgUp | PgDn | Clear | Main
```

Figure 21-27.IPR*4 10/100BT ARP Table Screen

21.13.5 IPR*4 Port Screen

Once the ethernet side of the IPR*4 card has been setup, then the HDLC T1/E1 WAN link side can be setup using the **port** option from the IPR*4 anchor window. The card can support up to 128 links, with the first four of these links having the ability to handle higher bandwidth. Ports one through four can be assigned up to an entire T1 or E1 worth of bandwidth per port. When using multiple DS0 timeslots on the first four ports, the selected DS0 ports must be contiguous. The port interface for the IPR*4HDLC shown in Figure 21-20.

ZhoneIMACS P1 IPR*4HDLC Rev A0-0 Ser 00006 02-13-12 17:07					
	1	2	3	4	
STATE	actv	actv	actv	actv	
INTF NAME	93	170	109	128	
WAN	w1-2	w2-2	w3-1	w3-2	
TS	table	table	table	table	
PROTOCOL	hdlc	hdlc	hdlc	hdlc	
RIP Rx	on	on	on	on	
RIP Tx	v2	v2	v2	v2	
SH	yes	yes	yes	yes	
LINK ST	UP	UP	UP	UP	
Save Undo Refresh Copy < > porT Find find Next Perf					

Figure 21-28. IPR*4HDLC Port Display

The INTF NAME field must match the interface name previously entered into the INTF NAME screen for the far-end destination.

Table 21-14. IPR*4 Port Menu Option Settings and Defaults

Action	Function
Save	actv stdby
Undo	Removes any items marked to be saved.
Refresh	Refresh the current screen.
Copy	Copies the data on the given port to the next port.
<	Scroll down to the previous four HDLC ports
>	Scroll up to the next four HDLC ports
porT	Access the information for a given port number
Find	Searches to find an interface name
find Next	When searching for a name, uses the same Find parameters but locates the next occurrence in the Interface name table.
Perf	See performance data for the HDLC port
Main	Go back to the IPR*4 Interface Main Screen.

Find

Provides the user the ability to find a particular string in a name. For example, if the user knew that the string ATL was in use then the user could use the find function and search for the string “ATL”. Similarly, the user could search simply for “A”.

Find next

The find next command allows the system to scroll to the next occurrence of the string entered in the Find command. With 128 addressable ports, this is a useful function to locate end points through potentially several pages of entries without having to use the page up and down functions.

PERF

New in the 6.1.4 release is the gathering and display of Performance statistics on a per-port basis. The Receive and Transmit packets to a destination are shown, as well as the errors that may have occurred in the respective direction. This new screen is displayed in Figure 21-29.

ZhongIMACS		P1 IPR*4HDLC Rev A0-0 Ser 00006		02-13-12 17:10	
IP Router Port Statistics					
	1	2	3	4	
PACKETS RX:	0	0	0	0	
PACKETS TX:	0	0	0	0	
RX ERRORS:	0	0	0	0	
TX ERRORS:	0	0	0	0	

Refresh | Clear | Main

Figure 21-29. IPR*4HDLC port Performance Monitoring

This screen has been added, but presently the performance monitoring command does not retrieve any information. This will be added in a future CPU and router card release.

Table 21-15. IPR*4 10/100BT port Menu Option Settings and Defaults

Parameter	User Options	Default
STATE	actv stbby	stdby
INTF NAME	Unique 7-character string to identify the far end.	blank
WAN	none w1-1 w1-2 w2-1 w2-2 w3-1 w3-2 w4-1 w4-2	none
TS	1-32	1-32
PROTOCOL	hdlc	hdlc
RIP Rx	off on	on
RIP Tx	off v1 v2	v2
SH	yes no	yes
LINK ST	Display Only n/a UP or DOWN	n/a

State

Activates or deactivates the HDLC port. The settings are **actv** or **stdby**.

INTF NAME

Enter a seven character string to identify the remote end of the link. For HDLC links, this name must be in the **INTF NAME** screen to associate the IP address with a name. Once the link reaches the UP status with the remote end, pressing carriage return on this field will reveal the IP address and netmask of the remote end.

WAN

This field points to the WAN slot to carry the HDLC link. Options are **wan** (w1-1 through w4-2).

TS

Ports 1 through 4 can be set for any number of contiguous timeslots, up to 24 for T1 (DSX) WAN and 32 for E1 (CEPT) WAN. For ports 5 through 128, these can set for a single DS0 only.

PROTOCOL

This display-only field indicates HDLC.

RIP Rx

Set each port to turn RIP receive **on** or **off**, the default is **on**. This option can be disabled by setting it to **off**. The following are internally set defaults for RIP, they cannot be changed:

- a) Update Interval: 30 seconds
- b) Invalid: 90 seconds
- c) Hold Down: 30 seconds
- d) Garbage: 240 seconds

RIP Tx

Set each port to transmit RIP packets in **v1** or **v2** mode - or turn it **off**. **v2** is the default.

SH

Enables or disables split horizon on Ethernet. Options are **yes** or **no**. Split-horizon route advertisement is a method of preventing routing loops in distance-vector routing protocols (such as RIP) by prohibiting a router from advertising a route back onto the interface from which it was learned.

LINK ST

This display-only field shows the state of the HDLC T1/E1 carrier facility. This field denotes the state of **UP** if the facility is in-service with no alarms, **TRBL** if the facility is in-service and in alarm, and **DOWN** if the facility is in a standby state. If there is no provisioning, or there is a communication issue to the IPR*4 card, then the default of **n/a** is displayed.

21.13.6 IPR*4 Static Route Screen

```

ZhoneIMACS | P2 IPR*4HDLC Rev A0-0 Ser 12345 | 02-13-12 17:10
page: 1 of 1      IP Router STATIC MENU
IP Net          Subnet          GoTo          Dist
192.168.1.1    255.255.255.0    164.16.7.0   1
Refresh | Add | dElete | pgUp | pgDn | Main

```

Figure 21-30. IPR*4 Static Route Entry

Table 21-16. IPR*4 10/100BT IP Static Routes Configuration Table Screen Actions

Action	Function
Refresh	Refreshes the current screen
Add	Adds the selected information on the screen (e.g. IP net, Subnet, etc.)
dElete	Deletes the selected information from the screen
pgUp	Scrolls up through the list of IP static routes
pgDn	Scrolls down through the list of IP static routes
Main	Returns to the IP Interface Menu screen

When adding a static route, the following input is required:

IP NET

A destination IP network address. Enter a valid IP address (e.g. 125.15.0.0).

SUBNET

A subnet mask. Enter a valid subnet mask (e.g. 255.255.0.0).

GOTO

IP address of the next IP gateway for this static route. Enter a valid IP address gateway (e.g. 192.168.1.254).

DIST

Administrative distance (in hops) for this static route.



Note: *The static routes will always be preferred to dynamic routes regardless of the Distance. This Distance will, however, be advertised in any routing updates for this static route.*

21.14 IPR*4 Server Card Specifications

IPR*4 Card (Models 883270, 883275 and 883280))

**Physical Interface (Models 883270,
883275 and 883280))**

Card Height	8 inches (20 cm)
Card Width	15/18 inches (2.35 cm)
Card Depth	7.5 inches (18.75 cm)
Power Consumption	10.7 Watts
BTU per hour	36.5
Operating Temperature	0 to 50 C, 32 to 122 F
Storage Temperature	-20 to 80 C, -4 to 176 F
Humidity	0 to 95% humidity, non-condensing

IPR*4 Card (Models 883270, 883275 and 883280)

IEEE	802.3i
	802.3u
IETF	RFC 768
	RFC 791
	RFC 792

Chapter 22

MCC Card

22.1 Introduction

This chapter provides installation, configuration, and troubleshooting information for the Management Channel Concentrator (MCC) card.

Note that this card is labeled as an ACS card on its faceplate ejector, and it is called an ACS-MCC card only in the user interface screens described in this chapter. Throughout this chapter, it is referred to as the ACS-MCC card.

22.2 ACS-MCC Card Descriptions

22.2.1 ACS-MCC Card Description (881360)

The ACS-MCC card uses 631xx MCC firmware and allows you to manage remote Integrated Access Systems by using TCP/IP or SNMP/UDP/IP communication protocols. The control link to each remote system can be the FDL (Facility Data Link) bits of an ESF-framed T1 line. Or, for an E1 line, this link can use the SA4 bits in the frame alignment words of the E1 signal. Full time slot B7R requires a DACSII 6.1 or equivalent. *MCC doesn't talk direct to FDL link, this requires a DACs to convert full timeslot B7R to B4R.*

The ACS-MCC card incorporates four Munich32 chips (two on the main board and two on a daughterboard), which allow up to 128 WAN interfaces. The ACS-MCC card also supports three configurable high-speed ports (C1, C2, and C3), plus an Ethernet 10Base-T port for LAN routing management.

The MCC can route IP datagrams between all of its interfaces, based on each datagram's IP destination address. Datagrams are directed (or routed) to the interface carrying the sub-net to which the datagram belongs or is being transported to, according to the content of the routing table. The routing table may be supplied with dynamic routes from the Routing Information Protocol (RIP) when enabled. If no match is found in the routing table, a default route can be designated to direct all unresolved datagrams to a specific interface.

Figure 22-1 shows the role of the ACS-MCC card in a Network Management System. Both SNMP alarm traps and TELNET configurations run over this path. They can use the FDL (T1 line), the SA4 bit of the frame alignment word (E1 line), or a full DS0 time slot of a T1 or E1 line.

The FDL is a 4 kbps channel that uses every other framing bit of the T1 extended superframes. When the FDL is used for remote system control via TCP/IP, T1 performance statistics are not gathered.

The SA₄ bit of the E1 frame alignment word is the first bit of time slot 0 of each frame. This bit is called the *national* bit; it also comprises a 4 kbps data channel.

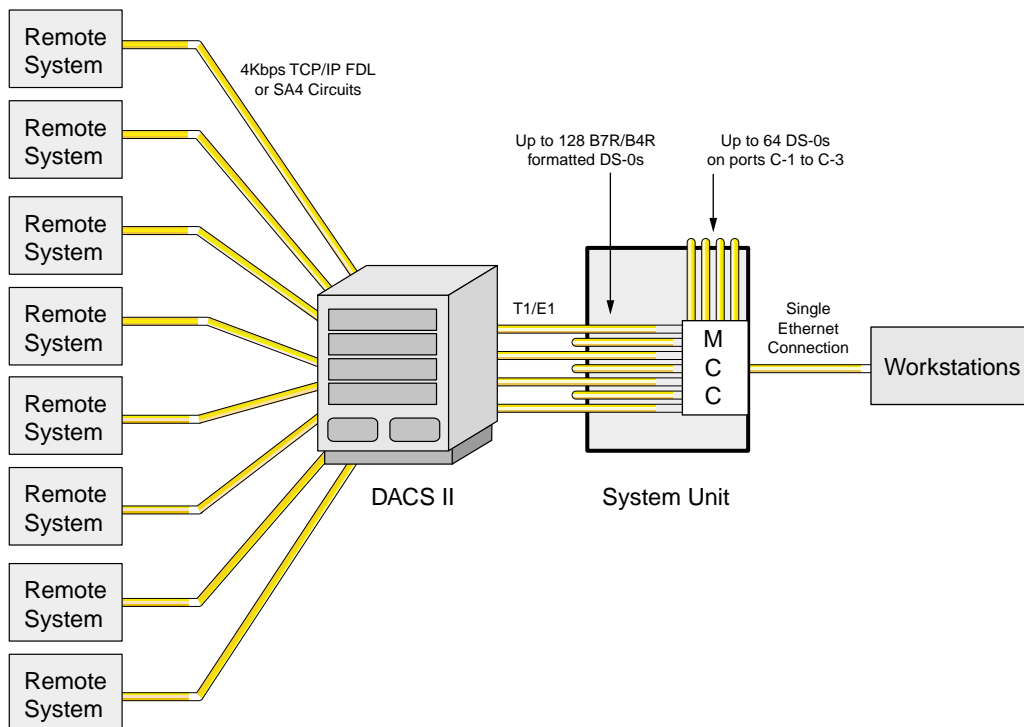

Figure 22-1. Typical MCC Application

If the FDL is used to transmit and receive information, a DACSII (6.1 or higher) must be used to convert the FDL/IP information into DS0. On point-to-point circuits, the DACSII is not needed. The MCC can also be used to create larger "trees" in which the high-speed ports (C1, C2, and C3) can interconnect the different ACS-MCC cards in the hierarchy.

22.2.1.1 Jumper/Switch Settings

The ACS-MCC card does not have any jumpers or switch settings.

22.2.1.2 Installing the Card

Insert the ACS-MCC card into one of the server card chassis slots (P1 to P3). The system can accommodate up to three server cards.

22.3 ACS-MCC Card User Screens and Settings

22.3.1 ACS-MCC Card Main Screen (Ethernet Port Configuration)

The ACS-MCC card routes datagrams onto Ethernet at the NMS site for communications with the NMS. Figure 22-2 shows the ACS-MCC Card Main Screen, in which you must set various parameters for the Ethernet interface. To go to this screen, highlight the desired card in the System Main Screen and press <Enter>.

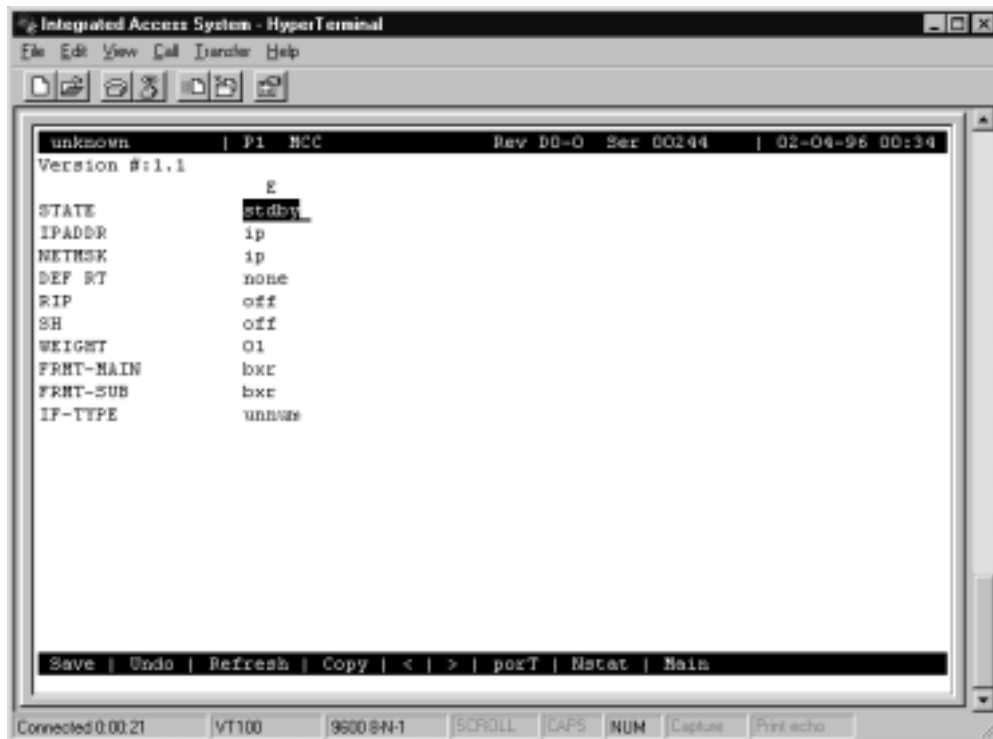

Figure 22-2. Typical ACS-MCC Card Main Screen

The bottom highlighted line of this screen shows numerous actions that you can perform from this screen. To perform the desired action, simply press the key shown by an uppercase letter. For example, to save your configuration settings, press “s” to invoke the **Save** command. Table 22-1 lists the available screen actions, and Table 22-2 summarizes the ACS-MCC card Main Screen parameters and available option settings. These parameters and settings are also described in the following paragraphs.

Table 22-1. Main Screen Actions

Action	Function
Save	Saves changes to settings.
Undo	Returns all settings to the last saved state.
Refresh	Redraws the screen.
Copy	Copies the contents of the current column to the next column. Useful if you change a lot of entries in one column and want to repeat those changes in subsequent columns.
<	The “less than” symbol scrolls backward through the 128 ports associated with this card.
>	The “greater than” symbol scrolls forward through the 128 ports associated with this card.
porT (C1-C3)	The port option allows you to “jump” to a specific port. Enter the number of the port you wish to see, press the <Enter> key, and the requested port will be displayed. To return to the Main Screen, press “e” and then press <Enter>.
Nstat	Displays the Network Data Screen.
Main	Returns to the System Main Screen. If changes are made to settings and not saved, you will be prompted to save or lose changes.

Table 22-2. Main Screen Option Settings and Defaults

Parameter	User Options	Default
STATE	stdby actv	stdby
IPADDR	ip	0.0.0.0
NETMASK	ip	0.0.0.0
DEF RT	none stat dyn	none
RIP	off rx tx rx/tx	off
SH	off on	off
WEIGHT	01-15	01
FMT-MAIN	bxr hdlc	bxr
FMT-SUB	bxr hdlc	bxr
IF-TYPE	unnum num	unnum

STATE

The State setting determines whether the port is active or inactive. Set the State to **stdby** (standby) to disable the Ethernet port, or choose **actv** (active) to enable the port.

IPADDR

When configured for unnumbered interfaces, the IP Address setting identifies the global IP Address of the MCC. This address is thus valid regardless of the state of the Ethernet port. When configured for numbered interfaces, the IP address of the Ethernet port identifies the IP address of the Ethernet interface only.

NETMASK

The IPADDR together with the NETMASK identifies the IP network for the Ethernet interface. Any valid netmask address is acceptable.

DEF RT

The Default Route setting identifies the IP Address of the port used to forward IP datagrams with destination unknown to the MCC. When **stat** (static) is selected, the IP address must be entered by the user. When **dyn** (dynamic) is selected, the IP address is dynamically assigned by a router. RIP must be turned on if **dyn** is selected. The default is **none**.

RIP

When the Routing Information Protocol (RIP) setting is **off** (default), no RIP traffic is allowed into or out of the Ethernet interface. Setting this variable to **rx** allows incoming RIP traffic only, while setting it to **tx** allows only outgoing RIP traffic. Setting this variable to **rx/tx** allows both incoming and outgoing RIP traffic.



Note: Due to the high number of interfaces on the ACS-MCC card and the relatively low bandwidth of the Munich interfaces, you should be careful when implementing the RIP option.

SH

When the Split Horizon (SH) variable is set to **on**, the ACS-MCC card does not automatically send RIP information along routes it "learned" through the same interface. The default is **off**.

WEIGHT

The Weight parameter assigns a weighting variable to the specified interface. The number must be between **1** and **15**. The default is **1**.

FMT-MAIN

This parameter is used to indicate the format of the 64 ports on the main board. When **bxr** is selected, ports 1 through 64 are configured to B4R (E1) or B7R (T1). When **hdlc** is selected, ports 1 through 64 are configured to 64 kbps. (See note below for exception.)

FMT-SUB

This parameter is used to indicate the format of the 64 ports on the sub-board. When **bxr** is selected, ports 65 through 128 are configured to B4R (E1) or B7R (T1). When **hdlc** is selected, ports 65 through 128 are configured to 64 kbps. (See note below for exception.)



***Note:** The only invalid configuration for FMT-MAIN and FMT-SUB occurs when FMT-MAIN = **bxr** and FMT-SUB = **hdlc**. This configuration is not supported.*

IF-TYPE

The IF-TYPE parameter determines the IP addressing scheme to be used by all interfaces (except the Ethernet interface, which is always numbered). The default option is **unnum**, which causes the interfaces to be unnumbered. When configured in this manner, the MCC is addressed through the global IP address of the Ethernet interface, regardless of the originating interface, and the IP address of all interfaces (except the Ethernet interface) is determined by the interface on the remote end. Selecting **unnum** may help conserve IP address, but may not be compliant with the HP OpenView network management system.

The **num** option allows for numbered interfaces. When this option is selected, each interface is assigned a local IP address on the same network as (but different from) the remote device. Two broadcast IP addresses are also reserved for each interface, for a total of four IP addresses per port. Numbered interfaces are industry-standard, and are compliant with the HP OpenView network management system.

22.3.1.1 C-Port and Numbered Port Configuration (1.1 Version Only)

After establishing the card's Ethernet parameter settings, configure the card's ports. From the ACS-MCC Card Main Screen, press "t" (**porT** command) to go to its ports. The ACS-MCC card has three high-speed ports (C1, C2, and C3) and 128 other ports (1 to 128), in addition to the Ethernet port.

Table 22-3 shows a typical C-Port Screen. After pressing "t" above, choose the C-ports (C1, C2, and C3) and 128 other ports (1 to 128) to view this screen.

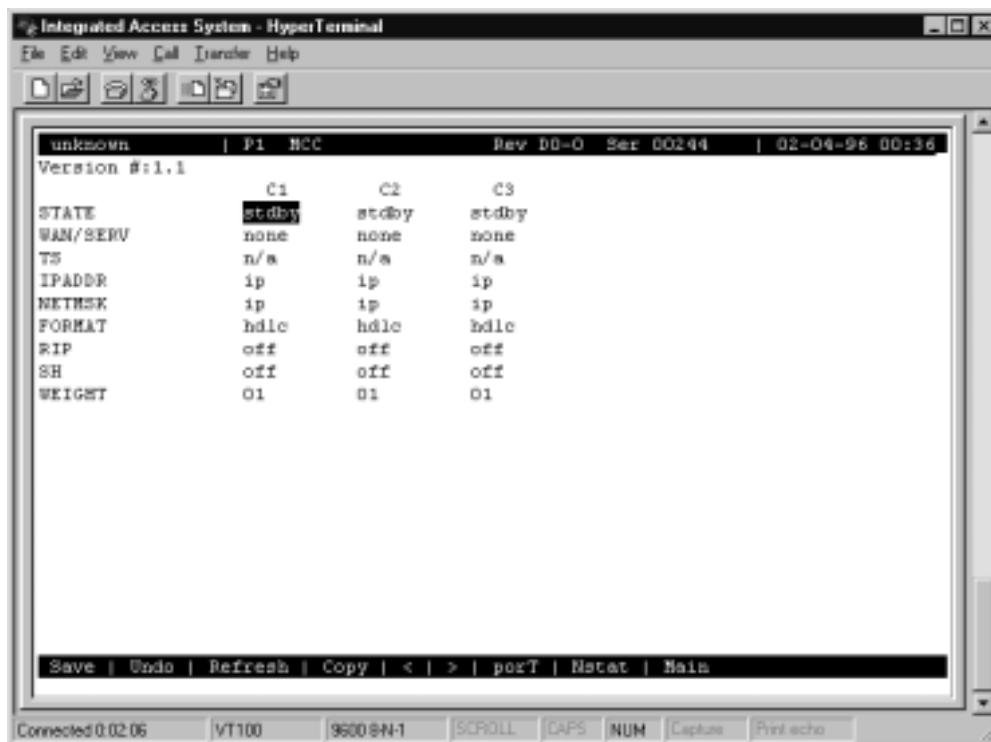

Figure 22-3. Typical C-Port Screen

The "less than" (<) and "greater than" (>) keys allow you to scroll through the other numbered ports associated with this card. Figure 22-4 shows a Typical Numbered Port Screen. Table 22-2 lists the options and defaults for the card ports.

Table 22-3 lists the actions you can perform from either screen. To perform an action, press the key indicated by the capitol letter on the bottom highlighted line of the screen.

Table 22-4 lists the Port Assignment Screen parameters and available setting. These are also described in the following paragraphs.

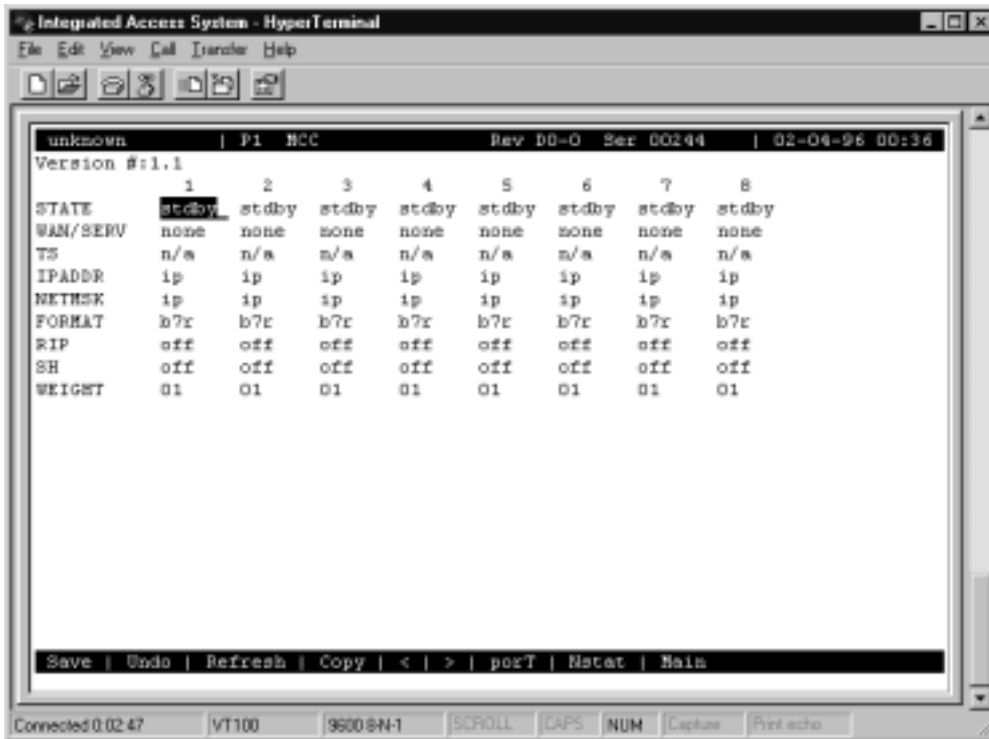

Figure 22-4. Typical Numbered Port Screen

Table 22-3. Port Assignment Screen Actions

Action	Function
Save	Saves changes to settings.
Undo	Returns all settings to the last saved state.
Refresh	Redraws the screen.
Copy	Copies the contents of the current column to the next column. Useful if you change a lot of entries in one column and want to repeat those changes in subsequent columns.
<	Scrolls backward through the 128 ports associated with this card.
>	Scrolls forward through the 128 ports associated with this card.
porT (C1-C3)	The port option allows you to “jump” to a specific port. Enter the number of the port you wish to see, press the <Enter> key, and the requested port will be displayed. To display the Ethernet port, press “e” and then press <Enter>.
Nstat	Displays the Network Data Screen for the current port.
Main	Returns to the System Main Screen. If changes are made to settings and not saved, you will be prompted to save or lose changes.

Table 22-4. Port Screen Option Settings and Defaults

Parameter	User Options	Notes	Default
STATE	stdby actv		stdby
WAN	none w1-1 through w4-2		none
TS	n/a 1-24 1-31		n/a
IPADDR	ip		0.0.0.0
NETMASK	ip		0.0.0.0
FORMAT	b7r b4r hdlc fr	1	see note 1
RIP	off rx tx rx/tx		off
SH	off on		off
WEIGHT	1-15		1

Notes:

1. For ports C1, C2, and C3, the options are **hdlc** (default) and **fr**. For ports 1 to 128, the options are **b7r** (default) and **b4r**.

STATE

The State setting determines whether the port is active or inactive. Set the State setting to **stdby** (standby) for ports you are not using or have not yet configured. Set it to **actv** (active) for ports that are ready for use.

WAN

The WAN setting identifies the WAN link on which the system information is sent. This signal will come from either the distant system unit or the DACSII™. The options are **none** and **w1-1** to **w4-2**. Ports 65 to 128 are limited to WAN links **w2-1** through **w4-2**.

TS

The Time Slot setting identifies the specific time slot on the WAN link (from the previous paragraph) used for this particular port. The options are **n/a**, **1-24** (for T1 links) and **1-31** (for E1 links).

IP ADDR

The IP Address setting identifies the IP Address of the remote end. Any unique valid IP address is acceptable.

NETMASK

The NETMASK setting together with the IP ADDR identifies the network for this port.

FORMAT

The Format setting determines the format of the information received from the remote system unit. For the numbered ports (1-128), the options are **b7r** (for T1 links) and **b4r** (for E1 links). For ports C1-C3, the options are **hdlc** (high-level data link control) and **fr** (frame relay). If **fr** is selected, the user must select a DLCI (data link connection identifier), which corresponds to the virtual circuit number of the frame relay destination address. When more than one TS is selected, the MTU is 1,500. The internal MTU is expanded by four on the WAN segment to allow 1,500 byte frames to pass with the addition of the frame relay header without fragmentation. When **fr** is selected, more than one TS must be allocated.

RIP

When the Routing Information Protocol (RIP) setting is off (default), no RIP traffic is allowed into or out of the Ethernet interface. Setting this variable to rx allows incoming RIP traffic only, while setting it to tx allows only outgoing RIP traffic. Setting this variable to rx/tx allows both incoming and outgoing RIP traffic.



***Note:** Due to the high number of interfaces on the ACS-MCC card and the relatively low bandwidth of the Munich interfaces, the user should be cautious about implementing the RIP option, as there is a substantial risk of broadcast storms causing congestion in the network.*

SH

When the Split Horizon (SH) variable is set to **on**, the ACS-MCC card does not automatically send RIP information along routes it "learned" through the same interface. The default is **off**.

WEIGHT

The Weight parameter assigns a weighting variable to the specified interface. The number must be between **1** and **15**. The default is **1**.

NETWORK DATA

The Network Data Screens provide maintenance and diagnostics information for this equipment. Statistics begin to accumulate when the port is changed from **stdby** to **actv** and they continue to store information until the port is changed back to **stdby**. These are status information screens; you cannot edit their data.

22.4 Network Port Statistics Screen

Figure 22-5 shows typical statistics for a network port (in this case, C1 port). To view this data, type “n” in the ACS-MCC Card Main Screen to invoke the **Nstat** command. Then, enter the desired port number. This data is described in the following paragraphs.

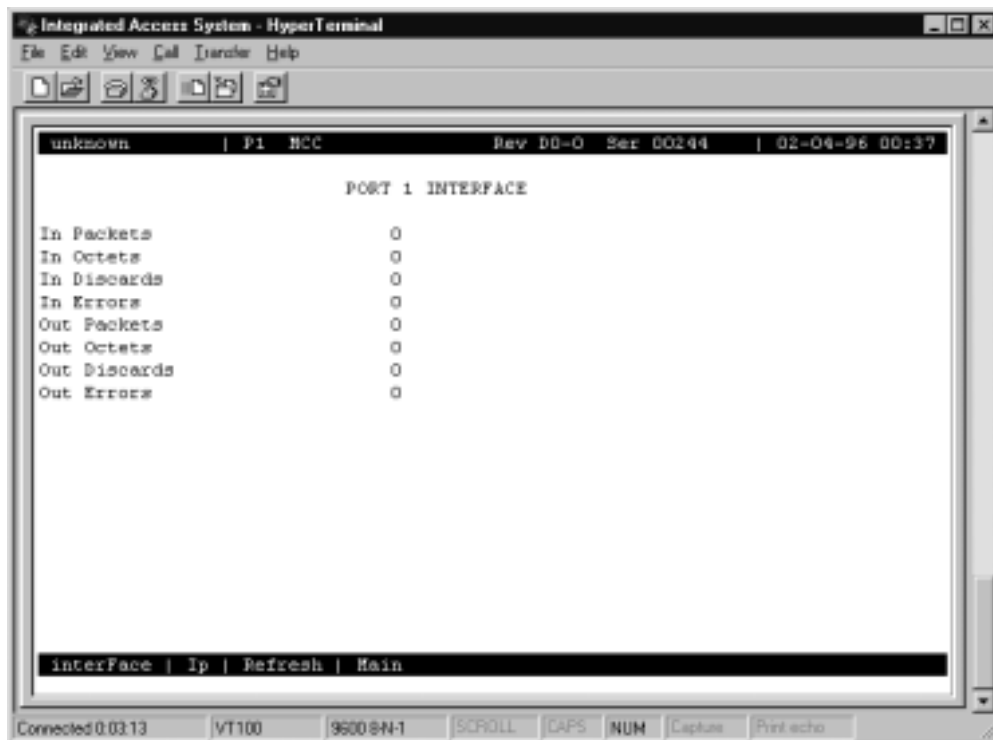

Figure 22-5. Typical Network Port Data Screen

IN PACKETS

The In Packets counter shows the total number of packets received from the remote systems through this port.

IN OCTETS

The In Octets counter shows the total number of octets received from the remote systems for this port.

IN DISCARDS

The In Discards counter shows the total number of packets received from the remote systems and discarded due to lack of resources for this port.

IN ERRORS

The In Errors counter shows the total number of packets received from the remote systems that had CRC errors when received.

OUT PACKETS

The Out Packets counter shows the total number of packets sent to the remote systems by the NMS equipment.

OUT OCTETS

The Out Octets counter shows the total number of octets sent to the remote systems by the NMS equipment.

OUT DISCARDS

The Out Discards counter shows the total number of packets that were sent to the remote systems and discarded due to lack of resources.

OUT ERRORS

The Out Errors counter shows the total number of errors related to packets transmitted.

Table 22-5 lists the other actions you can perform from the Network Port Statistics Screen. These actions appear on the bottom highlighted line of the statistics screen. To perform an action, just press the letter that corresponds to the uppercase letter associated with the desired action.

Table 22-5. Network Port Data Screen Actions

Action	Function
interFace	Switches from the IP Data Screen to the Interface Data Screen.
Ip	Switches from the Interface Data Screen to the IP Data Screen.
Refresh	Data collection is not updated automatically. Pressing the “r” key will update all data fields.
Main	Returns to the System Main Screen.

22.4.1 MCC Protocol Stack Data Screen

Figure 22-6 shows typical statistics for the ACS-MCC card protocol stack. To display this data, press “i” in the Network Port Statistics Screen to invoke the **Ip** command. These statistics are described in the following paragraphs.

```

Integrated Access System - HyperTerminal
File Edit View Call Transfer Help

unknown | P1 MCC Rev D0-0 Ser 00144 | 02-04-96 00:37

MCC CARD PROTOCOL STACK STATISTICS

--- IP Netstat ---
Datagrams In 0
Input Datagrams Discarded 0
Output Datagrams Discarded 0
Datagrams Forwarded 0
Requests Out 0
--- ICMP Netstat ---
In Messages 0
Out Messages 0
In Errors 0
In Echo Requests 0
In Echo Replies 0
Out Echo Requests 0
Out Echo Replies 0
In Destination Unreach. 0
Out Destination Unreach. 0

interFace | Ip | Refresh | Main

Connected 0.03.36 | VT100 | 9600 8N-1 | SCROLL CAPS NUM | Capture Print echo

```

Figure 22-6. Typical MCC Protocol Stack Data Screen

DATAGRAMS IN

The Datagrams In counter shows the total number of IP datagrams received from the remote systems.

INPUT DATAGRAMS DISCARDED

The Input Datagrams Discarded counter shows the total number of IP datagrams received that were discarded.

OUTPUT DATAGRAMS DISCARDED

The Output Datagrams Discarded counter shows the total number of IP datagrams sent to the remote system and discarded.

DATAGRAMS FORWARDED

The Datagrams Forwarded counter shows the total number of IP datagrams that were received from the remote systems and then forwarded.

REQUESTS OUT

The Requests Out counter shows the total number of IP datagrams that originated at the MCC.

IN MESSAGES

The In Messages counter shows the total number of ICMP messages sent by the remote systems.

OUT MESSAGES

The Out Messages counter shows the total number of ICMP messages sent to the remote systems.

IN ERRORS

The In Errors counter shows the total number of ICMP messages sent by the remote systems and had errors when received.

IN ECHO REQUESTS

The In Echo Requests counter shows the total number of ICMP echo requests sent by the remote systems.

IN ECHO REPLIES

The In Echo Replies counter shows the total number of ICMP echo replies sent by the remote systems.

OUT ECHO REQUESTS

The Out Echo Requests counter shows the total number of ICMP echo requests sent to the remote systems.

OUT ECHO REPLIES

The Out Echo Replies counter shows the total number of ICMP echo replies sent to the remote systems.

IN DESTINATION UNREACH

The In Destination Unreachable counter shows the total number of “destination unreachable” requests sent by the remote systems.

OUT DESTINATION UNREACH

The Out Destination Unreachable counter shows the total number of “destination unreachable” requests sent to the remote systems.

22.5 ACS-MCC Card Error Messages

Refer to Appendix B in the System Reference Guide for further information on Error Messages regarding this card.

22.6 ACS-MCC Card Troubleshooting

MCC card problems could indicate a number of possible causes, including:

- Misconfigured IP parameter at the far end
- Faulty cabling between the MCC LAN port and the LAN
- T1 or E1 network failure
- Improper network configuration
- Improper MCC card configuration

Typically, a problem is indicated by the inability to route IP traffic to/from or through the MCC card. You can perform numerous tasks to isolate the trouble and clear it. When troubleshooting problems on IP communications through an MCC card, follow this general sequence:

1. If all IP traffic is affected, verify that the US/EUR jumper is correctly placed to match the US/EUR jumper on the chassis. The MCC card performs a self-test on power-up. A “healthy” card will have a green LED lit on the front panel. Do not proceed with further steps until a green LED is present.
2. Verify that the Ethernet Port (**E**) is **actv** and that the correct IP address (**IPADDR**) and **NETMASK** have been entered. At this point, attempt to “ping” (from the CPU card TCP/IP screen) the IP address of the MCC Ethernet port from another device on the LAN. Pressing **N** from this screen will display the Network Statistic registers for the Ethernet port. Analyze the information to determine the cause of the failure. Do not proceed with further steps until this ping is successful.
3. From the CPU Main Menu screen, go to the TCP/IP screen by pressing **I**. Verify that the options and addresses on the TCP/IP screen are correct. Press “**P**” (for ping) and enter the IP address of the MCC card Ethernet port.
4. If Step 3 is not successful, verify that the **DEFAULT IP PORT** is set to **serv** and that the **DEFAULT IP SLOT** is set to the chassis slot in which the MCC card resides (**P1**, **P2**, or **P3**). At this point, attempt to ping the card again by pressing **P**. Do not proceed until this ping is successful.
5. Verify that the T1 or E1 network is working properly by checking for current CGA-Red and CGA-Yellow alarms. If no CGA alarms are present that would affect IP traffic, continue with step 6.

6. Verify the configuration settings for the affected MCC port. Be sure the port is connected to the proper WAN card and port, that the correct **FORMAT** is selected and that the appropriate IP address (**IPADDR**) and **NETMASK** have been entered. If these assignments appear correct, go back to the CPU TCP/IP menu and ping the address of the remote device connected to that MCC port. If this is not successful, ping back toward the MCC card from the remote device. Pressing **N** from the MCC card Port screen will display the Network Statistic registers for the port. Analyze the information to help determine the cause of the failure. The problem may be either in the network between the MCC port and the remote device, or incorrect IP addressing/configuration of the remote device.
7. If the MCC card is determined to be faulty, replace it and return the faulty unit for repair to the location specified by your distributor.

Appendix A

Appendices

System Standards and Specifications

A.1 Introduction

This appendix lists the Integrated Access System standards, specifications, compliance, power sources and pre-installation settings for the user cards.

A.2 Standards Compatibility

The following is a comprehensive list of standards that the System Chassis, Common Equipment and User Cards comply to, or are compatible with. Cards and components are listed alphabetically in each area:

System: Chassis, CPU, Interface cards, Power Supplies, WAN cards

Voice: E&M, FXO, FXS

Data: DS0-DP, HSU, OCU-DP, OHSU, SRU

Server: ADPCM, Analog Bridge, IPR*4

System		
Chassis		
ANSI	310-D	Racks, Panels, and Associated Equipment
Bellcore	GR-63-CORE Issue 1	Network Equipment-Building System (NEBS) Level 3 Requirements: Physical Protections
	GR-1089-CORE Issue 2	Network Equipment-Building System (NEBS) Level 3 Requirements: Electromagnetic Compatibility and Electrical Safety
	TR-NWT-000295 Issue 2	Isolated Ground Planes: Definition and Application to Telephone Central Offices
CEN	EN 500 081-1	Electromagnetic compatibility generic emission standard Part 1 Residential, commercial and light industry.
	EN 500 082-1	Electromagnetic compatibility generic immunity standard Part 1 Residential, commercial and light industry.
	EN 60 950/A2	Safety of information technology equipment including electrical business equipment
UL	1459	UL Standard for Safety of Telephone Equipment
CSAC22.2	No. 950	Safety of information technology equipment including electrical business equipment
FCC	Part 68 - Subpart B	Requirements for Connection of Terminal Equipment Systems and Protective Apparatus to the Telephone Network.
IEC	297-1	Racks, Panels and Associated Equipment
	950 A2	Safety of information technology equipment including electrical business equipment
CPU		
Bellcore	GR-63-CORE Issue 1	Network Equipment-Building System (NEBS) Requirements: Physical Protections
CEN	EN 500 081-1	Electromagnetic compatibility generic emission standard Part 1 Residential, commercial and light industry
CEN	EN 500 082-1	Electromagnetic compatibility generic immunity standard Part 1 Residential, commercial and light industry
CEN	EN 60 950/A2	Safety of information technology equipment including electrical business equipment
UL	1950	UL Standard for Safety of Information Technology Equipment
CSA	C22.2, No. 950	Safety of information technology equipment including electrical business equipment
IETF	RFC 1769	Simple Network Time Protocol (SNTP)",
	RFC 2865	Remote Authentication Dial In User Service (RADIUS).

IEEE	RFC 2882	Extended RADIUS Practices
	RFC 5424	The Syslog Protocol
	802.3i	10BASE-T 10 Mbit/s (1.25 MB/s) over twisted pair.
	802.3u	100BASE-TX, 100BASE-T4, 100BASE-FX Fast Ethernet at 100 Mbit/s (12.5 MB/s) w/auto negotiation

Interface Cards

ITU-T	V.28	Electrical characteristics for unbalanced double-current interchange circuits
	G.703	Physical/Electrical Characteristics of Hierarchical Digital I/F
	V.22 bis	2400 bits per second Duplex Modem Using the Frequency Division Technique
EIA	EIA 5618 Position Non-Synchronous RS232-C	Interface between DTE and DCE Employing Serial Data Interchange
Bellcore CEN	GR-63-CORE Issue 1	Interface between DTE and DCE Employing Serial Binary Data Network Equipment Building System (NEBS)
	EN 500 081-1	Electromagnetic compatibility generic emission standard Part 1 (Residential, commercial and light industry)
FCC	EN 60 950/A2	Safety of information technology equipment including electrical business equipment
	Part 68 - Subpart B	Requirements for Connection of Terminal Equipment Systems and Protective Apparatus to the Telephone Network
UL	1459	UL Standard for Safety of Telephone Equipment
	1950	UL Standard for Safety of Information Technology Equipment
CSA	C22.2, No.950	Safety of information technology equipment including electrical business equipment

Power Supplies

CEN	EN 60 950/A2	Safety of information technology equipment including electrical business equipment
CSA	C22.2, No. 950	Safety of information technology equipment including electrical business equipment
UL	1459, 3rd edition	UL Standard for Safety, Telephone Equipment

WAN Cards

AT&T	TR43801	Digital Channel Bank Requirements & Objectives
	TR54016	Requirements for Interfacing Digital Terminal Equipment to Service Employing the Extended Superframe Format
Bellcore	TR62411	Accunet T1.5 Service, Description and Interface Specifications
	TR-TSY-000008	Digital Interface Between the SLC 96 Digital Loop Carrier System and a Local Digital Switch (Issue 2 08/87)
ANSI	TR-TSY-000191	Alarm Indication Signal, Requirements and Objectives
	T1.101	Synchronization Interface Standards for Digital Networks
	T1.107	Digital Hierarchy - Formats Specifications
ITU-T	T1.403	ISDN, Network-to-Customer Installation - DS1 Metallic Interface
	T1.408	ISDN Primary Rate
	G.703	Physical/Electrical Characteristics of Hierarchical Digital I/F
	G.704	Synchronous Frame Structure Used at Primary and Secondary Hierarchical Levels
	G.732	Characteristics of Primary PCM Multiplexed Equipment Operating at 2048 Kbps.
	G.735	Characteristics of Primary PCM Multiplexed Equipment Operating at 2048 Kbps and Offering Synchronous Digital Access at 384 Kbps and/or 64 Kbps
	G.736	Characteristics of A Synchronous Digital Multiplex Equipment at 2048 Kbps

	G.823	The Control of Jitter and Wander Within Digital Networks which are based on the 2048 Kbps Hierarchy
	G.824	The Control of Jitter and Wander within Digital Networks which are based on the 1544 Kbps Hierarchy
Safety and EMC of WAN Cards		
Bellcore	GR-63-CORE Issue 1	Network Equipment-Building System (NEBS) Requirements: Physical Protection
UL	1950	UL Standard for Safety of Information Technology Equipment
CSA	C22.2, No. 950	Safety of Information Technology Equipment including Electrical Business Equipment
	EN 500 081-1	Electromagnetic compatibility generic emission standard Part 1 Residential, commercial and light industry.
	EN 500 082-1	Electromagnetic compatibility generic immunity standard Part 1 Residential, commercial and light industry.
	EN 60 950/A2	Safety of information technology equipment including electrical business equipment

Voice**E&M Cards**

Bell System	TR433801	Digital Channel Bank Requirements and Objectives - November 1982
	TR-NWT-000057	Functional Criteria for Digital Loop Carrier System - January 1993
	GR-63-CORE Issue 1	Network Equipment-Building System (NEBS) Requirements: Physical Protection
ITU-T	G.712 (11/96)	Transmission Performance Characteristics of Pulse Code Modulation (replaces G.712, G.713, G.714 and G.715)
	Q.552	Transmission Characteristics of 2-wire analog interface of a Digital Exchange
	Q.553	Transmission Characteristics of 4-wire analog interface of a Digital Exchange
FCC	Rules and Regulations	Part 68 and Part 15 - Subpart B (Subpart B supersedes Subpart J)
UL	1459, 3rd edition	UL Standard for Safety Telephone Equipment
UL	1950	UL Standard for Safety of Information Technology Equipment
CEN	EN 500 081-1	Electromagnetic compatibility generic emission standard Part 1 Residential, commercial and light industry
	EN 500 082-1	Electromagnetic compatibility generic immunity standard Part 1 Residential, commercial and light industry
	EN 60 950/A2	Safety of information technology equipment including electrical business equipment

FXO Cards

AT&T	TR43801	Digital Channel Bank Requirements and Objectives November 1982
	TR-NWT-000057	Functional Criteria for Digital Loop Carrier System January 1993
	GR-63-CORE Issue 1	Network Equipment-Building System (NEBS) Requirements: Physical Protection
ITU-T	G.712 (11/96)	Transmission Performance Characteristics of Pulse Code Modulation (replaces G.712, G.713, G.714 and G.715)
	Q.552	Transmission Characteristics of 2-wire analog interface of a Digital Exchange
	Q.553	Transmission Characteristics of 4-wire analog interface of a Digital Exchange
FCC	Part 68, and Part 15 - Subpart B	Subpart B supersedes Subpart J
UL	1459, 3rd edition	UL Standard for Safety, Telephone Equipment

FXS Cards

AT&T	TR43801	Digital Channel Bank Requirements and Objectives November 1982
	TR-NWT-000057	Functional Criteria for Digital Loop Carrier System - January 1993
	GR-63-CORE	Issue 1 - Network Equipment-Building System (NEBS) Requirements: Physical Protection
ITU-T	G.712 (11/96)	Transmission Performance Characteristics of Pulse Code Modulation (replaces G.712, G.713, G.714 and G.715)
	Q.552	Transmission Characteristics of 2-wire analog interface of a Digital Exchange
	Q.553	Transmission Characteristics of 4-wire analog interface of a Digital Exchange
FCC	Part 68 and Part 15 - Subpart B	Subpart B supersedes Subpart J
UL	1459, 3rd edition	UL Standard for Safety Telephone Equipment

Data

DS0-DP

ITU-T	G.703	Physical/Electrical Characteristics of Hierarchical Digital I/F
-------	-------	---

HSU Cards

BellCore	GR-63-CORE Issue 1	Network Equipment-Building System (NEBS) Requirements: Physical Protection
ITU-T	V.35	Data Transmission of 48 kbps using 60-108 kHz Group Bank Circuits
	V.11 (10/96)	Electrical characteristics for balanced double-current interchange circuits operating at data signaling rates up to 10 Mbps
	V.28	Electrical characteristics for unbalanced double-current interchange circuits
	G.704	Synchronous frame structures used at 1544, 6312, 2048, 8488 and 44 736 Kbps hierarchical levels
	V.25bis	(Model 8213 only) Automatic answering equipment and general procedures for automatic calling equipment on the general switched telephone network including procedures for disabling of echo control devices for both manually and automatically
EIA	RS-422	Electrical Characteristics of Balanced Voltage Digital Interface Circuits
	RS-449	General Purpose 37 Position and 9 Position Interface for DTE and DCE Equipment Employing Serial Binary Data Interchanges
	RS-530	High Speed 25 Position Interface for Data Terminal Equipment, Including Alternative 25 Position Connector
	RS-366	Interface Between Data Terminal Equipment and Automatic Calling Equipment for Data Communication
UL	1950	UL Standard for Safety of Information Technology Equipment
CEN	EN 500 081-1	Electromagnetic compatibility generic emission standard Part 1 Residential, commercial and light industry
	EN 500 082-1	Electromagnetic compatibility generic immunity standard Part 1 Residential, commercial and light industry
	EN 60 950/A2	Safety of information technology equipment including electrical business equipment
IEEE	C37.90	Tele Protection Equipment (TPE) compliance.

OCU-DP Card

AT&T	TR 62411	Accunet T1.5 Service, Description and Interface Specifications
Bellcore	TA-TSY-000077	Digital Channel Banks-Requirements for Data port Channel Unit Functions, Issue 2, April 1986
	TA-TSY-000083	Generic Requirements for the Digital Data System (DDS) Network Office Channel Unit, Issue 2, April 1986
BellCore	Pub 62310	DS0 Digital Local Channel Description and Interface Specification, August 1993
ANSI	T1.107-1988	Digital Hierarchy - Format Specifications 1988

OHSU Card (Models 823760, 823870 and 823875)

IEEE	c37.94i	Standard Optical Fiber Interfaces (2002)
------	---------	--

SRU Card

BellCore	GR-63-CORE Issue 1	Network Equipment-Building System (NEBS) Requirements: Physical Protection
AT&T	TR54075	Subrate Data Multiplexing - A Service of DATAPHONE Digital Service
ITU-T	V.24	Definitions of Interchange Circuits Between DTE and DCE
	V.28	Electrical characteristics of unbalanced double-current interchange circuits

	X.50	Division 3 Fundamental Parameters of a Multiplexing Scheme for the International Interface Between Synchronous Data Networks (note: does not support 600bps data)
	V.14	Transmission of Start-Stop Characters over Synchronous Bearer Channels (using Async to sync converters)
EIA	RS232-C	Interface Between DTE and DCE Employing Serial Binary Data Interchange
UL	1950	UL Standard for Safety of Information Technology Equipment
CEN	EN 500 081-1	Electromagnetic compatibility generic emission standard Part 1 Residential, commercial and light industry
	EN 500 082-1	Electromagnetic compatibility generic immunity standard Part 1 Residential, commercial and light industry
	EN 60 950/A2	Safety of information technology equipment including electrical business equipment

Server

ADPCM Card (Models 887160 and 887170)

ITU-T	G.726	Adaptive Differential Pulse Code Modulation (ADPCM)
-------	-------	---

Analog Bridge Card (Model 885070)

ITU-T	G.726	Adaptive Differential Pulse Code Modulation (ADPCM)
-------	-------	---

IPR*4 Card (Models 883270, 883275 and 883280)

IEEE	802.3i	10BASE-T 10 Mbit/s (1.25 MB/s) over twisted pair.
	802.3u	100BASE-TX, 100BASE-T4, 100BASE-FX Fast Ethernet at 100 Mbit/s (12.5 MB/s) w/auto negotiation
IETF	RFC 768	User Datagram Protocol
	RFC 791	INTERNET PROTOCOL
	RFC 792	Internet Control Message Protocol
	RFC 793	Transmission Control Protocol
	RFC 826	Ethernet Address Resolution Protocol
	RFC 1058	Routing Information Protocol
	RFC 1661	The Point-to-Point Protocol (PPP)
ISO	RFC 2453	RIP Version 2
	ISO 13239	High Level Data Link Control (HDLC)

A.3 Chassis Standards

A.3.1 Dimensions

Chassis Description	Model Number	Height		Width		Depth		Weight	
		in	cm	in	cm	in	cm	lb.	kg
600 Chassis with Installation Kit Steel Chassis, Front Loading, "V" Steel Card Guides, CE Marked	891630	9.12	23.16	17.042	43.29	9.121	23.19	7.44	3.38
800 Chassis with Installation Kit, Steel Chassis, Front and Rear Loading, "V" Steel Card Guides, CE Marked	891830	9.12	23.16	16.99	43.15	15.30	38.86	13.88	6.31
900 Chassis with Installation Kit, Power-Enhanced, Steel Chassis, Top and Bottom Front Loading, "V" Steel Card Guides, CE Marked	891930	15.38	39.05	16.92	42.97	9.11	23.13	15.28	6.95



Note: Weight is weight of empty chassis with backplanes and power distribution channel.

A.3.2 Chassis Power

Chassis Description	Model Number	AC Power (50-60 Hz)		DC Power		Power Consumption
		110 VAC	220 VAC	-48 VDC	24 VDC	Watts
600 Chassis with Installation Kit Steel Chassis, Front Loading, "V" Steel Card Guides, CE Marked	891630	90 VAC to 135 VAC	175 VAC to 264 VAC	-40 VDC to -60 VDC	+18 VDC to 35 VDC	125 (typical) 300 W (maximum)
800 Chassis with Installation Kit, Steel Chassis, Front and Rear Loading, "V" Steel Card Guides, CE Marked	891830	90 VAC to 135 VAC	175 VAC to 264 VAC	-40 VDC to -60 VDC	+18 VDC to 35 VDC	125 (typical) 300 W (maximum)
900 Chassis with Installation Kit, Power-Enhanced, Steel Chassis, Top and Bottom Front Loading, "V" Steel Card Guides, CE Marked	891930	115 VAC 104 to 135 VAC	175 VAC to 264 VAC	-40 VDC to -60 VDC	+18 VDC to 35 VDC	125 (typical) 500 W (maximum)

A.3.3 Environment

A.3.3.1 Ambient Temperature and Humidity

Ambient temperature and humidity as per GR-63-CORE R4-6 and R4-7.

Temperature °C / °F			Humidity	
Operate	Short Term	Storage	Operate	Short Term
0 to 50 °C 32 to 122 °F	-5 to 50 °C 23 to 122 °F	-20 to 80 °C -4 to 176 °F	50 to 95% relative humidity, non condensing	5 - 90 (not to exceed 0.024 kb H ₂ O/kg dry air)
Rate of temperature change		30 °C/hr (54 °F/hr)		

Ambient refers to conditions at a location 1.5 m (59 in) above the floor and 400 mm (15.8 in) in front of the equipment. Short-term refers to a period of not more than 96 consecutive hours and a total of not more than 15 days in 1 year. This refers to a total of 360 hours in any given year, but, no more than 15 occurrences during that 1 year period.

A.3.3.2 Altitude

As per GR-63-CORE R4-8. Functional within the limits specified in the table above when installed at elevations between 60 m (197 ft.) below sea level and 1800 m (5905 ft.) above sea level. As per O4-10. Functional within the limits specified in the table above when installed at elevations between 1800 m (5905 ft.) and 4000 m (13,123 ft.) above sea level.

A.3.3.3 Airflow

Convection cooled (no fans required). Except for Model 891930 Power Enhanced Chassis.

A.3.3.4 Fire Resistance

As per GR-63-CORE Section 4.2.2.2 Shelf-Level Fire-Resistance Criteria R4-19 for **Firespread** R4-20, **Fire Propagation** R4-21, O4-22 and O4-23.

A.3.4 Equipment Handling

A.3.4.1 Packaged Equipment Shock Criteria

As per GR-63-CORE Section 4.3.1.1 for category A containers, R4-41.

A.3.4.2 Unpackaged Equipment Shock Criteria

As per GR-63-CORE Section 4.3.2 R4-43.

A.3.5 Earthquake, Office Vibration and Transportation Vibration

A.3.5.1 Earthquake

To Zone 4 Profile (Zone 4 is most severe so equipment also meets Zones 0, 1, 2, and 3 criteria). Physical performance as per GR-63-CORE Section 4.4.1.2 R4-44. Functional performance as per GR-63-CORE Section 4.4.1.2 R4-48 and R4-49.

A.3.5.2 Office Vibration

Physical performance as per GR-63-CORE Section 4.4.3.2 R4-56. Functional performance as per GR-63-CORE Section 4.4.3.3 R4-57.

A.3.5.3 Transportation Vibration

Physical performance as per GR-63-CORE Section 4.4.4.1 R4-58.

A.3.6 Cable/Power Connections

- Chassis Model 891630 - front panel
- Chassis Model 891830 - rear panel
- Chassis Model 891930 - front panel

A.3.7 Mounting

A.3.7.1 Types

EIA 19" (482 mm) Standard Open Rack or Enclosed Cabinet. WEKO 23" Standard Open Rack or Enclosed Cabinet. Wall and Table Mount.

A.3.7.2 Clearance

Chassis	Series 891630	Series 891830	Series 891930
Front	15" (38 cm)	15" (38cm)	15" (38cm)
Back	0" (0 cm)	10" (25 cm)	0" (0 cm)
Top	2" (5 cm)	2" (5 cm)	2" (5 cm)
Bottom	2" (5 cm)	2" (5 cm)	2: (5 cm)

NOTE: These clearance requirements also account for the distance requirement for removing cards from the chassis.

A.3.8 Number of Slots

Chassis	891630	891830	891930
Front Logic Backplane	11	9	18
CPU	2	2	2
Server	3 - note 1	3	3
WAN	4 - note 1	4	4
Interface	1	N/A	1
User	8 - note 1	N/A	8
Front Power Backplane	3 - note 2	2	7
Rear Logic Backplane	N/A	9	N/A
Interface	N/A	1	N/A
User	N/A	8	N/A
Rear Power Backplane	N/A	5	N/A

NOTE 1: 1 - 8 slots on the 8916 are multi-purpose. Three (3) will accept either Server or User cards and 4 will accept either WAN or user cards. Position four must be a User card.

NOTE 2 - These slots can accommodate either two (redundant) power supplies or a single power supply with a voltage converter and ringing generator or a single power supply with two ringing generators.

A.4 System Power Supplies and Converters

The following is a list of standards for the Integrated Access System power supplies, converters and ring generators.

Model 8901 AC Power Supply 120/240 VAC, CE Marked

Input Voltage	Self detecting 90VAC to 135VAC at 60 Hz 175VAC to 264VAC at 50 Hz
Input Frequency	47 to 63 Hz
Inrush Surge Current	maximum 12 amp peak at 264 VAC cold start
Output Power	55 W Continuous
Max. No. per System	2
Redundancy	Optional
Ventilation	Convection Cooled
Protection	Unit is fused and protect from short circuits and over-voltage
Approvals	EN 60950/A2, EN 50 081-1, EN 50 082-1, UL 1459, UL 1950, CSA-C22.2 No. 950

Model 8902 DC Power Supply -48 VDC, CE Marked

Input Voltage	-42 to -60 VDC
Inrush Surge Current	maximum 12 amp at 60VDC
Output Power	55 W Continuous
Max. No. per System	2
Redundancy	Optional
Ventilation	Convection cooled
Protection	Unit is fused protected from short circuits and over-voltage Unit is diode protected from reversed polarity
Approvals	EN 60950/A2, EN 50 081-1, EN 50 082-1, UL 1459, UL 1950, CSA-C22.2 No. 950

Model 8903 Power Converter 120 VAC to -48 VDC

Input Voltage	90 VAC to 132 VAC
Input Frequency	60 Hz
Inrush Surge Current	maximum 20 amp peak at 132 VAC cold start
Output Power	100 W Continuous
Output Voltage	-48.0 VDC
Output Current	2 amp
Max. No. per System	2
Redundancy	Optional
Ventilation	Convection cooled
Approvals	UL 1459, UL 1950, CSA-C22.2 No. 950

Model 8904 Internal Ringing Generator (Discontinued)

Input Voltage	44 to 56 VDC
Output Power	10 W
Output Voltage	105 VDC rms default - adjustable from 60 to 105 Vrms
Output Current	100 mA rms
Output Frequency	20 Hz
Max. No. per System	5, 1 Master, up to 4 Slave
Redundancy	There is no provision for Master Ringer redundancy, however the slave units back each other up.
Ventilation	Convection cooled
Approvals	En 60950/A2, EN 50 081-1, EN 50 082-1, UL 1459, UL 1950, CSA-C22.2 No. 950

Model 8905 Power Converter 120/240 VAC to -48 VDC, 100 W, CE Marked

Input Voltage	90 Vrms to 260 Vrms
Input Frequency	50/60 Hz
Output Power	100 W Max.
Output Voltage	-48.0 VDC
Output Current	2 amp
Max. No. per System	2
Redundancy	Optional
Ventilation	Convection cooled
Approvals	EN 60950/A2, EN 50 081-1, EN 50 082-1, UL 1459, UL 1950, CSA-C22.2 No. 950

Model 8906 Ring Generator, -48 VDC

Input Voltage	45 to 56 VDC
Efficiency	60% at 48 V and 1 kOhm load
Protection	5 A slow blow fuse, primary current limiting
Noise	Less than 32 dBrnc
Output Voltage	100 VDC rms default - adjustable from 60 to 105 Vrms
Output Current	160 mA RMS Continuous
Output Frequency	20 Hz \pm 1 Hz
Protection	Output short circuit and overload protection
Operational Modes	Strap selectable: Master or Slave
Max. No. per System	
600 System	1
800 and 900 System	5:1 Master, up to 4 Slave
Redundancy	There is no provision for Master Ringer redundancy, however the slave units back each other up.
Ventilation	Convection cooled
Approvals	UL 1459, UL 1950, CSA-C22.2 No. 950

Model 8907 Power Supply -24 VDC, CE Marked

Input Voltage	18 to 36 VDC
Input Surge Current	Maximum 12 amp at 36 VDC
Output Power	Continuous 55 W
Max. No. per System	2
Redundancy	Optional
Ventilation	Convection cooled
Protection	Unit is fused protected from short circuits and over-voltage Unit is diode protected from reversed polarity
Approvals	EN 60950/A2, EN 50 081-1, EN 50 082-1, UL 1459, UL 1950, CSA-C22.2 No. 950

Model 8908 Power Converter 120/240 VAC to -48 VDC, CE Marked

Input Voltage	100 Vrms to 260 Vrms
Input Frequency	50/60 Hz
Output Power	300 W Continuous
Output Voltage	-48 VDC
Output Current	7 amp
Max. No. per System	2
Redundancy	Optional
Ventilation	Fan cooled
Approvals	EN 60950/A2, EN 50 081-1, EN 50 082-1, UL 1459, UL 1950, CSA-C22.2 No. 950

A.4.1 Power Supply Compatibility

Power Sources	AC Power Supply	-48V Power Supply	-48V Converters	Ringling Gen.	+24V Power Supply	External -48 VDC Power	External Ringling Generator
AC Power Supply	---	yes	yes	yes	yes	yes	yes
-48V Power Supply	yes	---	no	yes	no	yes	yes
-48V Converters	yes	no	---	yes	no	no	yes
Ringling Gen.	yes	yes	yes	---	no	yes	no
+24V Power Supply	yes	no	no	no	---	no	yes
External -48 VDC Power	yes	yes	no	yes	no	---	yes
External Ringling Generator	yes	yes	yes	no	yes	yes	---

A.4.2 External Talk Battery Fuses

Manufacturer	Part NumberA3
Little Fuse	218.005
Bussman	GDC-5

A.5 Card Specifications

A.5.1 Current in milliamperes, weight and power consumption

Item	Model	+5VDC	-5VDC	+12VDC	-12VDC	Weight		Power	
						lb	kg	watt	BTU/hr
Common Equipment									
CPU Card 7.X	880770	680	0	16	0	.75	.32	3.59	12.3
Interface Card	893270	125	0	5	0	1.25	.57	0.69	2.34
Interface Card	893370	175	0	5	0	1.0	.45	0.94	3.19
Interface Card	893470	75	0	5	0	1.0	.45	0.44	1.48
Network Cards									
WAN Card	801070	430	0	50	0	.75	.32	2.75	9.38
WAN-R Card	801470	432	0	194	0	.75	.32	4.49	15.3
Voice Cards									
E&M Card	810860	84	70	104	16	1.0	.45	2.21	7.54
E&M Card	811960	84	70	104	16	1.0	.45	2.21	7.54
FXS Card	812960	96	73	112	17	1.0	.45	2.39	8.16
FXO Card	813960	99	75	105	15	1.25	.57	2.31	7.88
Data Cards									
DS0-DP Card	825460	259	0	2	0	.5	.23	1.32	4.5
HSU Card	820260	376	6	0	0	.5	.23	1.91	6.52
HSU Card	820360	344	20	13	0	.5	.23	1.98	6.74
HSU Card	821260	362	239	0	0	.5	.23	3.01	10.3
HSU Card	821460	428	12	0	0	.5	.23	2.2	7.51
HSU Card	821560	621	11	0	0	.5	.23	3.16	10.8
OCU-DP 5-Port	824160	450	0	34	0	1.0	.45	2.66	9.07
OCU-DP 10-Port	824660	928	0	69	0	1.0	.45	5.47	18.7
OCU-DP 2-Port	8249	203	0	44	0	.5	.23	1.54	5.26
OHSU 2P	823760	360	0	0	0	0	0	1.8	6.14
OHSU 4-port (820 nm)	823870	841	0	8	0	0	0	4.3	14.7
OHSU 4-port (1310 nm)	823875	841	0	8	0	0	0	4.3	14.7
SRU Card	822060	168	0	138	106	.5	.23	3.77	12.9
SRU C&D Bus	822160	168	0	138	106	.5	.23	3.77	12.9
SRU LD	822560	222	0	8	30	.5	.23	1.57	5.34
LD-SRU	822570	520	0	7	0	.75	.32	2.68	9.16
Alarm Cards									
Alarm Card	840160	5	0	45	0	.5	.23	0.57	1.93
Server Cards									
ADPCM Card	887170	550	0	11	0	.5	.23	2.88	9.83
Analog Bridge	885070	664	0	285	0	.5	.23	6.74	23.0
IPR 10BT Card	883160	625	0	5	0	1.0	.45	3.19	10.9
IPR*4	883270	1424	0	297	0	1.0	.45	10.7	36.5
MCC Card	881360	1550	0	0	0	1.0	.45	7.75	26.4

All IMACS cards are 8" x .94" x 7.5" or 20.3cm x 2.4cm x 19.0cm

A.5.2 Pre-Installation Card Setup

The table shown below lists all system user cards that require pre-installation setup. Refer to the separate card chapters in this manual for more information about system settings and configuration parameters.

Card	Model	Jumpers or Switches	Options
Ring Generator	8906	JP1	Master or Slave
Alarm Card	840160	JP1-4	Active / Passive
E&M Card	810860	SW1-4	S1-Source of the E (receive or Earth) lead; can be internal (INT) or external (EXT) S2-Internal source E lead; either battery (-48VDC) or ground (GND). S3-Internal source for transmit or magnetic lead; either battery (-48VDC) or ground (GND). S4-Switch (ON) for ground or open (OFF). All eight ports must be set to the same position (all ON or all OFF).
E&M Card	811960	SW1-4	GND / BAT Options
FXS Card	812960	JP1, JP2	JP1 (US/EUR) and JP2 for SL (Short Loop) and LL (Long Loop) between 700 Ohms and 1800 Ohms. Default is LL
FXO Card	813970	JP101 and JP102 through JP801 and JP802 in 100 increments.	For MRD mode, all jumpers must be installed. Otherwise leave at factory default (open).
HSU Card	820260	P1, 2 Switch	RS-530/V.35 IF Option
HSU Card	821360	RS-530, V.35	Card switches for operation of ports 1 and 2 in either the RS-530 or V.35 mode.
HSU Card	821460	JP3	US or European setting.
HSU Card	821560	P1-4 Switch	RS530/V.35 IF Option
HSU Card	821660	RS-530, V.35	Card switches for operation of ports 1 and 2 in either the RS-530 or V.35 mode.
SRU Card	822060	JP1, JP2	US and European jumper settings.
SRU C&D Bus Card	822160	JP1, JP2	US and European jumper settings.
WAN and WAN-rr	801070 / 801470	P1 and P2. J10, J11, J12. J11, J14, J15.	P1 and P2 set WAN channel 1 and 2 for DSX, E1 or CSU mode. Corresponding Jumper pairs not used for T1 / CSU, set for impedance values when E1 mode

A.6 FCC Requirements

The three tables below outline the FCC Registration Information for Part 1, Part 2 and Part 3 for these system cards.

Reg. Status	MTS/WATS Interfaces	Model #	Ringer Equiv. Number	SOC	Network USOC	Canadian Jacks
M	02LS2	FXO 2W*8-6	0.4B (ac), 0.0 (dc)	----	RJ11X	CA11X
M	02GS-2	FXO 2W*8-6	0.4B (ac), 0.0 (dc)	----	RJ11X	CA11X
Reg.	02LS2	INF+M T1E1	0.8B (ac), 0.0 (dc)	----	RJ11X	CA11X

Reg.	Analog PL Interfaces	Model #	SOC	Network USOC	Canadian Jacks
Reg.	0L13C	FXS 2W*8-6	9.0F	RJ21X	CA21A
Reg.	02LR2	FXS 2W*8-6	9.0F	RJ21X	CA21A
Reg.	TL11M	FXS 2W*8-6	9.0F	RJ2EX	CA2EA
Reg.	TL12M	FXS 2W*8-6	9.0F	RJ21FX	CA2FA
Reg.	TL11E	E&M 2W*8, E&M 4W*8	9.0F	RJ2EX	CA2EA
Reg.	TL12E	E&M 2W*8, E&M 4W*8	9.0F	RJ2FX	CA2FA
Reg.	TL31M	E&M 2W*8, E&M 4W*8	9.0F	RJ2GX	CA2GA
Reg.	TL32M	E&M 2W*8, E&M 4W*8	9.0F	RJ2HX	CA2HA
Reg.	TL31E	E&M 2W*8, E&M 4W*8	9.0F	RJ2GX	CA2GA
Reg.	TL32E	E&M 2W*8, E&M 4W*8	9.0F	RJ2HX	CA8HA

Reg.	Digital Interfaces	Model #	SOC	Network USOC	Canadian Jacks
Reg.	04DU9-BN	WAN SINGLE, WAN DUAL*	6.0Y	RJ48	CA81A
Reg.	04DU9-DN	WAN SINGLE, WAN DUAL*	6.0Y	RJ48	CA81A
Reg.	04DU9-1KN	WAN SINGLE, WAN DUAL*	6.0Y	RJ48	CA81A
Reg.	04DU9-1SN	WAN SINGLE, WAN DUAL*	6.0Y	RJ48	CA81A
Reg.	04DU9-1ZN	WAN SINGLE, WAN DUAL*	6.0Y	RJ48	CA81A
Reg.	04DU9-BN	WAN SINGLE, WAN DUAL**	6.0P	N/A	---
Reg.	04DU9-DN	WAN SINGLE, WAN DUAL**	6.0P	N/A	---
Reg.	04DU9-1KN	WAN SINGLE, WAN DUAL**	6.0P	N/A	---
Reg.	04DU9-1SN	WAN SINGLE, WAN DUAL**	6.0P	N/A	---
M	04DU5-24	OCU-DPx2	6.0F	RJ48	CA81A
M	04DU5-48	OCU-DPx2	6.0F	RJ48	CA81A
M	04DU5-56	OCU-DPx2	6.0F	RJ48	CA81A
M	04DU5-96	OCU-DPx2	6.0F	RJ48	CA81A

* in CSU mode

** in DSX mode

A.7 UK Requirements

Clearance (mm)	Creepage (mm)	Voltage Used or Generated By Host or Other Cards
2.0	2.4 (3.8)	Up to 50Vrms or VDC
2.6	3.0 (4.8)	Up to 125Vrms or VDC
4.0	5.0 (8.0)	Up to 250Vrms or VDC
4.0	6.4 (10.0)	Up to 300Vrms or VDC
For a host or other expansion card fitted in the host, using or generating voltages <i>greater</i> than 300V (rms or DC), advice from a competent telecommunications safety engineer must be obtained before installation of the relevant equipment.		Above 300Vrms or VDC

A.8 Year 2000 Compliance

All products are compliant with Bellcore Requirements GR-2945, *Year 2000 Generic Requirements: Systems and Interfaces*. The following key points about this compliance are noteworthy:

1. All dates displayed or printed by the Integrated Access System are used for reference purposes only. No calculations, except leap year calculations (see number 3 below), are based on these dates.
2. The displayed or printed dates use implicit century indications. In other words, years are displayed as two digit numbers and because the dates are assumed current, or near current, the century is implied. Since all dates are shown for reference purposes only, and are normally used by maintenance personnel to monitor system performance over a short time frame, the implicit century indication presents no confusion, miscalculation or potential ambiguity.
3. Leap year calculations are handled correctly under all circumstances except one: century years not evenly divisible by 400 will be falsely computed as leap years. The year 2000 is evenly divisible by 400 and the Integrated Access System correctly computes it as a leap year. The years 2100, 2200, 2300, 2500, etc. are all non-leap years, but the Integrated Access System will computer them as leap years.

A.8.1 Service requirements

If the product malfunctions, all repairs must be performed by the manufacturer or a Zhone-authorized agent. It is the responsibility of users requiring service to report the need for service to Zhone customer service.

A.9 Safety Information and Precautions

The equipment is designed and manufactured in compliance with Safety Standard EN60950. However, the following precautions should be observed to ensure personal safety during installation or service, and prevent damage to the equipment or equipment to be connected.

Read and follow all warning notices and instructions marked on the product or included in this Reference Guide.

Only qualified technicians should perform these tasks.

1. Never install telephone wiring during a lightning storm.
2. Never install telephone jacks in wet locations unless the jack is specifically designed for wet locations.
3. Never touch uninsulated telephone wires or terminals unless the telephone line has been disconnected at the network interface.
4. Use caution when installing or modifying telephone lines.
5. See the UL Statement for Voice Cards.
6. Never attempt to remove the power panel without first disconnecting input power cables.
7. Never attempt to operate this system when the power panel screws are removed. They provide the safety ground for the system.
8. This product is intended to be used with a three-wire grounding type plug - a plug which has a grounding pin. This is a safety feature. Equipment grounding is vital to ensure safe operation. Do not defeat the purpose of the grounding type plug by modifying the plug or using an adapter.

Prior to installation, use an outlet tester or a voltmeter to check the AC receptacle for the presence of earth ground. If the receptacle is not properly grounded, the installation must not continue until a qualified electrician has corrected the problem. If a three-wire grounding type power source is not available, consult a qualified electrician to determine another method of grounding the equipment.

9. Slots and openings in the cabinet are provided for ventilation. To ensure reliable operation of the product and to protect it from overheating, these slots and openings must not be blocked or covered.

Notice!

DO NOT place anything directly on top of unit that can block air holes.

-
10. **DO NOT** allow anything to rest on the power cord and do not locate the product where persons could step on or walk on the power cord.
 11. **DO NOT** attempt to service this product yourself. Refer all servicing to qualified service personnel.
 12. Special cables, which may be required by the regulatory inspection authority for the installation site, are the responsibility of the customer.
 13. When installed in the final configuration, the product must comply with the applicable Safety Standards and regulatory requirements of the country in which it is installed. If necessary, consult with the appropriate regulatory agencies and inspection authorities to ensure compliance.
 14. A rare phenomenon can create a voltage potential between the earth grounds of two or more buildings. If products installed in separate buildings are **interconnected**, the voltage potential may cause a hazardous condition. Consult a qualified electrical consultant to determine whether or not this phenomenon exists and, if necessary, implement corrective action prior to interconnecting the products.

WARNING!

This equipment has been tested and found to comply with the limits for a Class "A" Digital Device, pursuant to Part 15 of the FCC Rules. These limits are designed to provide reasonable protection against harmful interference when the equipment is operated in a commercial environment. This equipment generates, uses, and can radiate radio frequency energy, and, if not installed and used in accordance with this Reference Guide, may cause harmful interference to radio communications. Operation of this equipment in a residential area is likely to cause harmful interference, in which case the user will be required to correct the interference at their own expense.

The authority to operate this equipment is conditioned by the requirement that no modifications will be made to the equipment unless the changes or modifications are expressly approved by the manufacturer.

A.9.1 Disclaimer for Shielded Cables

This equipment was tested with shielded input/output and interface cables. It is recommended that shielded cables be used to reduce interference whenever interference is suspected.

A.9.2 Panel and Cover Removal

Only qualified service technicians should attempt the removal of covers and panels.

Notice!

Never attempt to operate the equipment with the power panel fasteners removed. Do not remove power panel covers without first disconnecting the input power.

A.9.3 Power Source

Please refer to *Appendix A, System Specifications* in the System Reference Guide regarding System Requirements.

A.9.4 Fusing

To avoid a fire hazard, use only fuses with the specified type and rating.

A.10 Power Supply Safety Information

The following information applies to systems with power supplies.

1. An equipment grounding conductor not smaller in size than the ungrounded branch-circuit supply conductors must be installed as part of the circuit that supplies the product or system. Bare, covered or insulated grounding conductors are acceptable. Individually covered or insulated equipment grounding conductors shall have a continuous outer finish that is either green, or green with one or more yellow stripes. The equipment-grounding conductor must be connected to ground at the service equipment.
2. The receptacles in the vicinity of the product or system must be of a grounding type. The equipment-grounding conductors serving these receptacles are to be connected to earth ground at the service equipment.
3. The DC Power Source must comply with the limits of SELV, and must provide reinforced insulation from AC Power Mains.

A.10.1 Grounding

The equipment can be grounded through the power cord as well as the terminal marked .

Notice!

For detailed information on grounding procedures, please see the Grounding information beginning in “System Power and Ground Connections” on page 2-14

Notice!

Passive Cooling Requirements

DO NOT Stack Units on top of one another. There MUST be at least 1” clearance between units.

A.10.2 Electrostatic Discharge Prevention

The plug-in cards contain components that could be damaged by electrostatic discharge. When handling any cards, wear a properly grounded wrist strap to prevent possible card damage, or follow other suitable precautions to prevent equipment damage.

A.10.3 Operator Services Requirements

This equipment is capable of giving users access to interstate providers of operator services through the use of equal access codes. Modifications by aggregators to alter these capabilities may be in violation of the Telephone Operator Consumer Services Improvement Act of 1990 and Part 68 of the FCC Rules.

A.11 Regulatory Compliance Information

A.11.1 FCC Part 68 Information

This equipment complies with Part 68 of the FCC rules.

The equipment has FCC Registration Number 1H5SNG-73866-DD-E. This equipment uses the following USOC jacks: RJ11C, RJ21X, RJ2EX, RJ2FX, RJ2GX and RJ2HX.

The Ring Equivalence Number (REN) is used to determine the quantity of devices that may be connected to the telephone line. Excessive RENs on the telephone line should not exceed five (5). To be certain of the number of devices that may be connected to the line, as determined by the total RENs, contact the telephone company to determine the maximum RENs for the calling area.

If this equipment causes harm to the telephone network, the telephone company will notify you in advance that temporary discontinuance of service may be required. If advance notice is not practical, the telephone company will notify you as soon as possible. Also, you will be advised of your right to file a complaint with the FCC if you believe it is necessary.

The telephone company may make changes in its facilities, equipment, operations, or procedures that could affect the operation of the equipment. If this happens, the telephone company will provide advance notice in order for you to make the necessary modifications to maintain uninterrupted service.

This equipment cannot be used on telephone company-provided coin service. Connection to Party Line Service is subject to state tariffs. This equipment is hearing aid-compatible.

A.11.2 CE Marking

The CE mark is affixed to those chassis that conform to the following Commission Directives:

- 89/336/EEC on the approximation of the laws of the Member States relating to electromagnetic compatibility.
- 73/23/EEC on the harmonization of the laws of the Member States relating to electrical equipment designed for use within certain voltage limits.
- 91/263/EEC on the approximation of the laws of the Member States concerning telecommunications terminal equipment, including the mutual recognition of their conformity.

A.11.3 Declaration of Conformity

Manufacturer

Zhone Technologies Inc.
7195 Oakport Street
Oakland, CA 94621
USA
Ph: (510) 777-7000

Authorized Representative in EC

2050 The Crescent
Solihull Parkway
Birmingham Business Park
Birmingham
B37 7YE
United Kingdom
Ph: 011-44-121-788-4100

We declare that the equipment listed herein conforms with the harmonized standards of the following European Commission Directives: 89/336/EEC, 72/23/EEC, and 91/263/EEC.

Name and Type of Equipment

IMACS/600, IMACS/800, IMACS/900 Integrated Multiple Access Communications Server

Under 89/336/EEC as amended by 92/31/EEC, and 93/68/EEC

In accordance with EN50081-1: EN55022

In accordance with EN50082-1

Under 72/23/EEC as amended by 93/68/EEC

EN60950 with Amendments A1 and A2

Under 91/263/EEC

In accordance with the following Common Technical Regulations:

CTR 12 - as described EC Type Examination Certificate BAPT/97/4841

CTR 13 - as described EC Type Examination Certificate BAPT/97/4841

CE MARK Affixed 1996

This Declaration is made 10 March 1998.

A.12 Country-Specific Regulatory Compliance Information

A.12.1 Canada

A.12.1.1 Canadian DOC Information

NOTICE TO USERS OF THE CANADIAN TELEPHONE NETWORK

The Canadian Department of Communications label identifies certified equipment. This certification means that the equipment meets certain telecommunications network protective, operational and safety requirements. The Department does not guarantee the equipment will operate to the user's satisfaction.

Before installing this equipment, users should ensure that it is permissible to be connected to the facilities of the local telecommunications company. The equipment must also be installed using an acceptable method of connection. In some cases, the company's inside wiring associated with a single line individual service may be extended by means of a certified connector assembly (telephone extension cord). The customer should be aware that compliance with the above conditions might not prevent degradation of service in some situations.

Repairs to certified equipment should be made by an authorized Canadian maintenance facility designated by the supplier. Any repairs or alterations made by the user to this equipment, or equipment malfunctions, may give the telecommunications company cause to request to disconnect the equipment.

Users should ensure for their own protection the electrical ground connection of the power utility, telephone line and internal metallic water pipe system, if present, are connected together. This precaution may be particularly important in rural areas.

CAUTION!

Users should not attempt to make such connections themselves, but should contact the appropriate electrical inspection authority, or electrician, as appropriate.

The Load Number (LN) assigned to each terminal device denotes the percentage of the total load to be connected to a telephone loop which is used by the device to prevent overloading. The termination on a loop may consist of any combination of devices subject only to the requirement that the total of all the Load Numbers of all the devices does not exceed 100.

A.12.2 Japan

A.12.2.1 Class A ITE Notification

この装置は、情報処理装置等電波障害自主規制協議会（VCCI）の基準に基づくクラス A 情報技術装置です。この装置を家庭環境で使用すると電波妨害を引き起こすことがあります。この場合には使用者が適切な対策を講ずるよう要求されることがあります。

A.12.3 Europe

A.12.3.1 European Telecommunication Approvals

Under the Telecommunications Terminal Directive the following connections are approved:

The WAN DUAL card, the WAN SINGLE card, and the 120 ohm version of the DSX/CEPT module are approved for connection to ONP unstructured and structured 2048 kbps digital leased lines with G.703 interfaces, following assessment against CTR12 and CTR13.

A.12.4 United Kingdom

A.12.4.1 UK Approval Number

The BABT approval number is M606037.

The WAN DUAL card, the WAN SINGLE card, and the 75 ohm version of the DSX/CEPT module, connected via the BNC connector panel are approved for connection to UK 2048 kbps digital leased lines with G.703 (75 Ohm) interfaces.

A.12.4.2 UK Compliance Statements

The E1 Interface is approved in the UK for direct connection to PTO-provided circuits operating at data rates up to 2.4Mbit/s.

The E1 Interface comprises a combination of single or dual WAN cards, CEPT modules, and connector panels as listed in the UK approval documentation.

The approved CEPT configuration options are shown below.

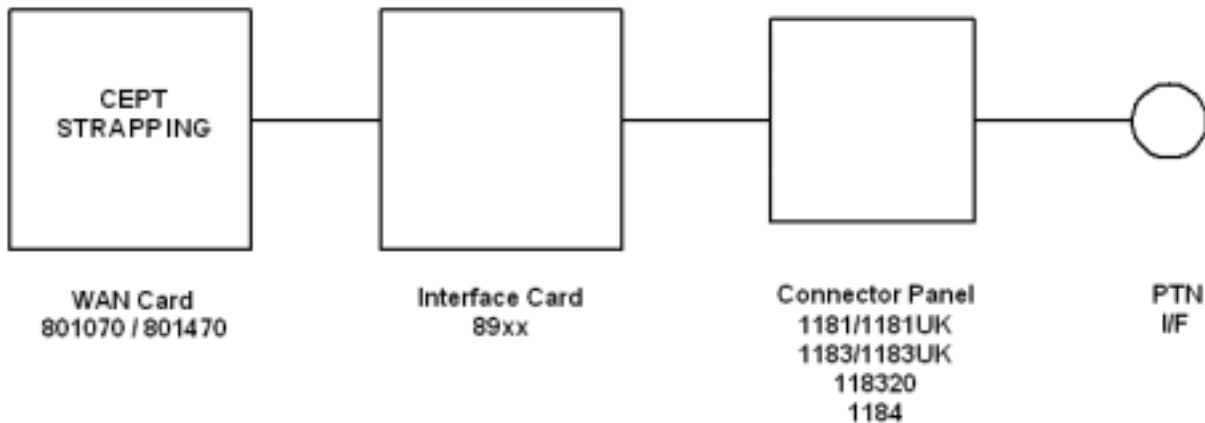

The Interface Card is also listed in the approval documentation and provides a direct metallic path between the CEPT module and appropriate Connector Panel.

The power required by the host and the total of all adapter cards installed within the host environment, together with any auxiliary apparatus, shall not exceed the power specification of the host apparatus.

Refer to Appendix A. System Specifications in this System Reference Guide for details on E1 interface power requirements.

It is essential when other option cards are introduced which use or generate a hazardous voltage, the minimum creepages and clearances are maintained. Suitable user protection to ensure compliance with EN 60950 should be present on the card. A hazardous voltage is one that exceeds 42.2V peak AC or 60VDC. If you have any doubt, seek advice from a competent installation engineer before installing other adapters into the host equipment.

The equipment must be installed such that with the exception of the connections to the host, clearance and creepage distances are maintained between the card and any other assemblies that use or generate a voltage. Large clearance and creepage distance applies where the local environment is subject to conductive pollution or dry non-conductive pollution which could

become conductive due to condensation. Failure to maintain these minimum distances would invalidate the approval. Refer to Appendix A. System Specifications in this System Reference Guide.

A.12.5 Germany

A.12.5.1 German Approval Number

The German approval number is A118 142F.

Safety Warning

SPEZIFISCHE SICHERHEITSMABNAHMEN

DIE EINRICHTUNG IST GEMÄß DEM SICHERHEITSTANDARD EN60950 ENTWORFEN UND HERGESTELLT WORDEN. DOCH DIE FOLGENDEN SICHERHEITSMABNAMEN SOLLEN EINGEHALTEN WERDEN. UM IHRE PERSÖNLICHE SICHERHEIT BEI INSTALLATION ODER BEI WARTUNG SICHERZUSTELLEN UND UM SCHADEN AN DER EINRICHTUNG ODER AN DER ZUM ANSCHLUß BESTIMMTEN EINRICHTUNG ZU VERMEIDEN.

ERDUNG

Die Einrichtung kann genauso durch das Netzanschlußkabel wie durch das mit gekennzeichnete Terminal geerdet werden.

STROMVERSORGUNG

Wechselspannung 120/240 Volts 2/1 Amps 50/60 Hertz

Gleichstrom 24/48 Volts 1/1.5 Amps

Die Gleichstromversorgung muß zusätzlich den Strom von der Versorgung abstellen können, und die Versorgungsspannung muß von einer isolierten Quelle gemäß der SELV-Voraussetzungen von EN60950 versorgt werden.

SCHMELZSICHERUNG

Um Brandgefahr zu vermeiden, dürfen Sie nur die Sicherung von der vorgeschriebenen Sorte und Nennwerte für die Einrichtung gebrauchen.

ENTFERNUNG VON PLATTEN UND ABDECKUNGEN

Die Abdeckungen und Platten sollen nur von einem qualifizierten Wartungs- oder Operationsperson entfernt werden.

Betreiben Sie nie die Einrichtung, wenn die Stromplattenverschlüsse entfernt worden sind, und entfernen Sie nie die Stromplattenabdeckung, ohne zuerst die Stromversorgung abzustellen.



Appendix B

Error Messages

B.1 Error Messages Introduction

This appendix lists the Integrated Access System error messages. One of these messages may appear at the bottom of the screen when you enter a command, indicating that the system did not perform the requested action. This condition may have been caused by an operator error, absence of a card in the system, or other condition. If an error message appears, take the appropriate corrective action. For convenience, the system error messages are listed alphabetically.

‘0000’ invalid for E, reverted to original.

The sequence 0000 is not a valid ABCD signaling sequence on E1 links. Choose a different ABCD sequence for E1 signaling conversion to/from T1 format.

A name must be assigned to Circuit ID field.

You must enter a name for the circuit before attempting this operation. Go to the Circuit ID field, type the desired name, and save it.

ADPCM card is not installed or rdnt.

An ADPCM card is not present in the system, or you chose a redundant ADPCM card for data compression. Install an ADPCM card, or selected a non-redundant card.

Alarm Card can’t be active with dialing.

An External Alarm card cannot be used when HSU cards are programmed for ISDN dialing. Remove this card.

All available PVCs are already taken.

The number of PVCs available on the FRAD Card Main Screen has been exceeded by the number of PVCs assigned on the PVC Screen. Assign a number of PVCs on the PVC Screen that is lower than the quantity chosen in the Main Screen.

All blank prt report.

You chose the empty option setting for all four elements of the Print Alarm on the Interface Card. This combination of settings is invalid and cannot be saved. Choose the proper option settings for these elements.

ASYNCR/5 databits must have 2 stop or parity.

You have assigned an SRU card port to an asynchronous circuit with 5 data bits, one stop bit, and no parity. This is an invalid combination of option settings. Either choose two (2) stop bits, or enable parity on that port.

ATM PHY is not active.

The physical ATM port is not active.

B-channels must be allocated.

You are trying to activate an ISDN PRI D-channel that has no assigned B-channels. Assign B-channels to the D-channel.

Bad routing format.

The telephone numbers used for the ISDN-PRI routing table are not formatted correctly. Re-enter these numbers in the proper format.

Bad Service number format.

ISDN-PRI Server numbers must have two digits. The valid service number range is from 01 to 99.

BCH is not supported in XCON.

You cannot use BCH error correction on an OCU-DP card in systems with cross-connect WAN cards.

block number mismatch.

The user has downloaded code to a card, and tried to activate it. The bank noted in the downloaded file does not match the bank the user is trying to activate. The user must download the appropriate bank file.

Both WAN's cannot be in test mode.

You cannot use the test option on both sides of a cross-connect simultaneously.

Bridge port limit exceeded

The user has tried to enter a bridge participant number higher than 32.

Broadcast cannot be looped back.

You cannot activate a loopback on a broadcast cross-connection.

Bus cannot be looped back.

You cannot assign a multirate HSU port to more than 30 time slots of a WAN E1 link or 24 time slots on a T1 link.

Call manufacturer for availability.

You are trying to assign too many D-channels to the current ISDN-PRI card. Upgrade the card in your system, or replace it with one capable of supporting the desired number of D-channels. Call Technical Support for assistance.

Cannot be STDBY while BERT test is running.

You cannot change a port from the actv (active) state to the stdby (standby) state while the Bit Error Rate Tester (BERT) is running. You must end the BERT test first.

Cannot define any more PVC connections.

The maximum number of PVC connections has been reached.

Cannot define any more PVC endpoints.

The maximum number of PVC endpoints has been reached.

Cannot define any more XCON circuits.

The maximum number of cross-connect circuits is 99.

Can NOT delete circuit while test is active.

You must end the test in progress before deleting the circuit.

Cannot do it in Viewer mode.

You are logged in under the Viewer password, but that level of access does not allow you to perform the desired operation. Log out of the system, log back in under the Operator or Manager password, and repeat the command. Or, perform an operation that is permitted by the Viewer access level.

Cannot exceed 32 TS's for ports 1-32 or 33-64.

Each set of 32 ports can have one time slot (total of 32 time slots).

Cannot have REMOTE and LOCAL loopbacks.

You cannot place the card port in both a local loopback and a remote loopback simultaneously.

Cannot insert errors without BERT running.

You must start BERT testing before inserting bit errors.

Cannot read Act EEPROM with Sby present

A user cannot read or write to the active CPU when a standby CPU is present.

Cannot switch non-compatible WANs.

The current WAN card arrangement does not support redundant WAN switching.

Cannot switch to a non-operational WAN.

You cannot switch to the selected WAN card because it is out of service.

Cannot talk to NTU while BERT is running.

You must stop the BERT test before accessing the NTU.

Cannot use the same TS on different WAN.

You cannot assign an SRU card port to the same time slot on different WAN ports.

Can't define any more IP entries.

The maximum number of IP entries has been reached.

Can't initialize modem.

The Interface card modem was not initialized.

Card already installed.

You cannot use the Configuration option on an occupied chassis slot.

Card does not respond.

The card is not responding to your commands. Remove the card from the chassis, plug it back in again, and repeat the command. If the message appears again, replace the card.

Card has broadcast/monitor links.

You cannot place the HSU card in standby when it has active broadcast lines.

Card is not available.

You cannot test the card because it is faulty. Replace the card.

Channel test is available from WAN XCON screen.

To test a cross-connected voice circuit, go to the Cross-Connect Screen.

Checksum mismatch

A download has completed, and the checksum has completed but failed. The download experienced a data transfer issue, and must be restarted.

Circuit is already used, no subaddress allowed.

You cannot assign the same circuit number to different ports in the FRAD User Port screen.

Circuit name must be entered.

You must enter a name for the cross-connect circuit before attempting this command.

Combined ADPCM rate must equal 64K.

You cannot assign a 40 kbps and a 32 kbps channel to the same ADPCM 64 kbps engine. The only valid combinations are 40 kbps + 24 kbps, 32 kbps + 32 kbps, and 24 kbps + 40 kbps.

Command rejected. Switch in progress.

The command was not executed because a redundancy switch is in progress.

Config. changes must be made from primary WAN.

You cannot make configuration changes to a redundant WAN port. This is allowed only on primary WAN ports.

CONG stat is not available for FRAD port.

Frame relay packet congestion data is not available for this FRAD port.

Cumulative bandwidth exceeds 115.2K.

You cannot assign more than 115.2 kbps of aggregate bandwidth to an SRU card. Be sure the sum-total rate of all card ports does not exceed 115.2 kbps.

Current CPU does not support redundancy.

The selected CPU card does not support redundancy. If the system has two CPUs, be sure they are both 8803s.

D-channel is active.

You cannot change WAN parameters because ISDN D-channel associated with it is still active.

Dialing is not available with Alarm Card.

If an External Alarm card is present in the system, you cannot use dial triggers for the HSU card. Remove the External Alarm card first.

Do you want to send long test syslog(y/n)?

Prior to the system generating a longest syslog message, confirmation is required.

Download failed. Exit screen and try again

An attempt to download the IPR*4 card failed, likely due to a communications error.

Download failed. Try again later

An attempt to download the IPR*4 card failed, likely due to a checksum failure.

Do you want to send test syslog(y/n)?

Prior to the system generating a test syslog message, confirmation is required.

ds0-n available only with 64K rate.

You cannot generate a DS0 time slot (ds0-n) loopback on an OCU-DP port with a data rate of less than 64 kbps. This is possible only on ports operating at 64 kbps and higher.

Duplicate prt report element.

You have asked the Print Alarms option to print the same element twice.

Each WAN can have only one d-chan.

You cannot assign two D-channels to the same WAN port.

Empty field is not allowed.

You cannot assign a blank password on the CPU Card Main Screen. Always enter alphanumeric characters.

Empty flash, nothing to restore

The user has attempted to restore from flash, which has no data saved in it.

Empty slot.

You cannot access the card or associated screen because it is not plugged into the chassis.

ENETBRI/PRI card is not installed or config.

An Ethernet BRI/PRI card is not present in the system, and is not configured.

Engine pair must have same ADPCM WAN and TS.

You must assign each pair of ADPCM engines (1-2, 3-4, 5-6, etc.) to the same WAN port and time slot.

ERR COR bch_ts must be larger than TS.

For BCH error correction, you must assign a separate WAN time slot that is numerically higher than the time slot carrying the normal data.

Error correction is not supported.

Error correction is not supported on the five-port or ten-port OCU-DP card. Or, majority voting (maj-v option setting) error correction is not supported for data rates higher than 9.6 kbps. Use bch error correction instead, or do not use error correction.

ERROR found in the RESTORE file.

The system restoral failed due to a software error. Repeat the restoral, and call Technical Support if this message reappears.

Ethernet port must be active

An attempt has been made to use the xpress option to download the IPR*4 card with the Ethernet port turned off.

Failed

Generation of a test syslog message failed, perhaps due to permissions error of the requestee

Field can NOT be MODIFIED.

You cannot edit this field.

FR circuit is not defined.

You cannot assign a user circuit for an undefined Frame Relay PVC.

FR port and DLCI must be unique.

The Frame Relay port and DLCI must form a unique address for each PVC.

FR port is not active.

You cannot activate a PVC on an inactive Frame Relay port.

Group 'A' is not allowed for slcd4.

You cannot use trunk group A in the slcd4 mode.

Group already taken.

This group is already assigned.

Illegal address and mask combination.

The combination of IP address and mask numbers you chose is invalid. Change either the IP address or mask number.

Illegal IP Mask.

The IP netmask number you chose is invalid.

Intf. ID must be uniquely identified.

The ISDN PRI card must have a different two-digit number for each WAN port used for B-channels.

Invalid character in Node Id.

The only valid characters for a Node ID are alphanumeric characters and the underscore.

Invalid date/time format.

You have entered an invalid date or time.

Invalid Dlci value.

The DLCI number you chose is invalid.

Invalid endpoint name.

The endpoint name you chose is invalid.

Invalid IP address.

The IP address you chose is invalid.

Invalid IP netmask.

The IP netmask you chose is invalid.

Invalid parameters for ADPCM.

You cannot use ADPCM on voice cards that use A-Law coding. This is only allowed on mu-Law voice cards.

Invalid password for this command.

You cannot use the debug command from the System Test and Debug Screen without the proper password authorization.

Invalid secondary clock format.

You cannot assign an external clock source as the secondary system clock.

Invalid SR TS.

You cannot assign an SRU card subrate port to a WAN time slot that does not have enough room on the subrate time slot for that much bandwidth. For example, if you have a port with b-5 framing occupying subrate time slots 1 to 4, you cannot also assign a fifth port whose bandwidth exceeds 9.6 kbps to subrate time slot 5.

Invalid sub address.

You cannot assign the same subaddress number to two different user ports on the FRAD Card Main Screen.

Invalid Timeslot.

When assigning time slots to user voice and data ports, you must choose time slot number 1 to 24 for a WAN T1 port, or 1 to 31 for a WAN E1 port.

Invalid WAN/SRVR.

You cannot assign services to an unavailable WAN or Server card.

IP Address must be unique.

The IP address is already assigned.

ISDN connected circuit.

You cannot place an HSU card port with an active ISDN call in standby. Wait for the call to end.

ISDN, FRAD, ADPCM do not support WAN switch.

WAN redundancy is not available if any of those cards are used in the system.

Local LB & Test Pattern can't be ON together.

You cannot perform a loopback with a test pattern applied, and you cannot apply a test pattern if a loopback is active.

MAJ EC is not available with RATE> 9.6.

You cannot use majority-vote error correction on an SRU card port with a Rate higher than 9.6 kbps. Use bch error correction instead, or disable error correction.

Mode cannot be changed when any ts are allocated.

You cannot change the WAN card mode from d-i (drop and insert) to term (terminal), or vice versa, when time slots are occupied. First, make all time slots available.

Modification can't be saved while test is active.

You cannot make changes in this screen while a test is in progress.

Module is not installed.

You cannot use the Configuration option on a WAN port that doesn't have a CSU, DSX/CEPT, or HDSL plug-in module attached. Be sure to install the proper module(s) on the WAN card. For HDSL interfacing, an 8011 WAN Card is required.

Multi DS0 only allowed for PPP 1-4

Only ports one through four on an IPR*4 card are granted higher than a single DS0 of bandwidth.

Must be in terminal mode.

You cannot use the Configuration option on a WAN card in the drop-and-insert mode.

Must have clean WAN.

You cannot use the Configuration option on a WAN card whose time slots are already occupied.

Must have OOS status.

You cannot delete a card that has not been removed from the system. Remove the card first.

Must have WAN card installed.

You cannot use the Configuration option on an uninstalled WAN card. Install the card first.

N392 must be less than or equal to N393.

N392 determines the amount of errors that will be tolerated during the amount of events assigned in N393. FRAD rules require that N392 be less than or equal to N393.

No changes for selected switch.

When connected to an ISDN office switch, you cannot change the status of a B-channel.

No changes while BERT is running.

You cannot change the port configuration while Bit Error Rate Testing is active. Turn the test mode off before making your changes.

No d-i mode for this slot.

In a redundant cross-connect system, you cannot assign the drop-and-insert (d-i) mode to the WAN card in slot W3, which holds the redundant WAN card.

No historical alarms.

You have selected the History command in the Alarm Screen, but no alarms exist in that log.

No more profiles allowed.

You cannot assign more than 16 call profiles to the Interface Card.

No more than 1 ts allowed.

You cannot assign more than one WAN time slot to a FRAD circuit.

No more than 2 ts allowed.

The Frame Relay PVC circuit cannot exceed 128 kbps (two 64 kbps time slots).

No more than one BERT test per BRI card.

You cannot perform more than one BERT test on each BRI card.

No more than two WANs in BERT test are allowed.

You can place only two WAN ports in the BERT test mode simultaneously.

No NFAS for selected switch.

The ISDN office switch does not accept NFS B-channel assignments.

No second net-lb allowed when bw = 115.2 kbps.

You cannot activate more than one network loopback at a time on an SRU card port.

No timeslot(s) specified.

You cannot activate a user card that doesn't have any WAN time slots assigned to it.

No Voice Compress. WAN card using ALL resources.

No ADPCM card is currently available for voice compression.

Not applicable for S/T card.

This does not apply for a BRI S/T card.

Not enabled, cannot send test syslog

A request to send a test syslog message is denied, since the feature is turned off.

Not enough available U-slots.

You cannot use the Configuration option with less than three available user card slots in the chassis for T1 operation, or four available user card slots for E1 operation.

Not implemented yet.

You cannot use a feature or function that is not yet released. This message normally appears on software versions for beta testing.

Not ready to switch

A CPU switch command has been given, but checks to assure that the standby processor is ready to take over activity has failed. Wait 30 seconds and try again.

Not supported.

This command is currently not supported by the system.

Number of TS from must be equal to TS to.

You cannot assign a time slot cross-connection with an unequal number of “from” (source) and “to” (destination) time slots.

Only B-chan can be controlled.

You cannot update or delete a regular cross-connect circuit from the Cross-Connect Broadcast Screen.

Only broadcast/data type can be controlled.

You cannot update or delete a regular cross-connect circuit from the Cross-Connect Broadcast Screen.

Only network or data type can be broadcasted.

You cannot broadcast a Broadcast circuit from the Cross-Connect Broadcast Screen.

Only one ADPCM redundant in the system.

You cannot make more than one ADPCM a redundant card in the system.

Only one port can be at 128K.

You cannot configure more than one port of the card for 128 kbps.

Only U-slots can be configured.

You cannot use the Configuration option for the P slots, C slots, or I slot of a chassis.

Only w1-1 or w1-2 are supported.

You can use the Configuration option only on WAN ports W1-1 and W1-2.

Parameters are not saved.

You have selected the Main command from the bottom of the screen without first saving your changes. Press “s” to invoke the Save command first.

Parameters have been saved.

You have made changes to the card and typed “s” to invoke the Save command. (This is a normal message, it always appears when you type “s” to save changes.)

Performance statistics is not available in slc96.

You cannot obtain performance statistics for a WAN port in the slc96 mode.

Performance statistics not available.

You cannot obtain performance statistics for this card or port.

Phone number must be unique.

The primary phone number on an HSU card must be unique.

Port already configured for Remote Terminal.

This port is already configured for use with a remote terminal.

Port has PVC(s) allocated. No changes allowed.

You cannot deactivate a Frame Relay port with active PVCs.

Port is in use.

You cannot make any changes to an active port.

Port is not active.

You cannot use the Hangup option on an HSU card port in the standby state.

Port is not configured for ASCII.

This port is not configured for ASCII operation.

Port is not configured for TCP/IP.

This port is not configured for TCP/IP operation.

Primary WAN is not operational.

You cannot switch from a redundant WAN port back to a primary WAN port if the primary port is still not operational.

Profile has to be loaded first.

You cannot use the Dial command in the HSU Card Main Screen without first loading a call profile.

Profile Id was not found.

Upon using the Load command in the HSU Card Main Screen, you requested a non-existing call profile from the Interface card.

PVC has user circuits active. No changes allowed.

You cannot deactivate a Frame Relay PVC with active user circuit(s).

PVC name must be entered.

You must enter a PVC name before executing this command.

PVC name must be unique.

The current PVC name is already in use. Enter a different name.

RATE = 19.2 must have DATA = 8 for adpcm or hlink.

If you set the SRU card port rate to 19.2 kbps, you also must set the number of data bits for that port to 8.

Redundancy requires WAN Model 8014 in Slot W4.

Your system must have an 8014 WAN Card in slot W4 for WAN redundancy operation.

Redundancy switchover is complete.

You have asked the system to switch to the redundant WAN card, and the switchover was successfully completed. (This is not an error message; it normally appears after you initiate the switchover.)

Redundant CPU.

The current CPU card is the redundant card.

Redundant WAN is taken already.

You cannot switch to the redundant WAN card in slot WAN-4 if it is already in use from a previous WAN card switch.

Remote session active. Can't change setting.

You cannot change this setting because a remote operator has accessed the system and is controlling it. Wait for that operator to log off and disconnect.

Restricted field.

You cannot access the Superuser password field on the CPU Card Main Screen. This password is factory-assigned.

Secret Key cannot be blank

The RADIUS secret key must have valid characters.

Selected ADPCM can be primary only.

The current ADPCM card cannot be a redundant card.

Selected circuit is not primary.

The current circuit is redundant, not a primary circuit.

Selected circuit is under the test already.

The current circuit is already being tested.

Service table is currently used by profile.

You cannot change the service table on the ISDN configuration screen when the service is selected and stored in an Interface card call profile.

Simultaneous loopback tests not allowed.

You cannot activate two or more loopbacks at the same time.

SNMP Options not available on this CPU.

The current CPU card does not support SNMP configuration.

Specify Sys Ph# before activating REMOTE vt100.

You must enter the Integrated Access System's phone number before a remote operator can connect to the system.

SR TS overlapping.

The subrate circuit assigned does not allow enough space for a previously assigned circuit on the same subrate time slot. For example, if you have a 19.2 kbps device on subrate time slot 1 in b-5 framing, you cannot assign another 19.2 kbps circuit to subrate time slot 2, because the circuit on 1 actually occupies subrate time slots 1 and 2. You must therefore assign that other circuit to subrate time slot 3 or 4.

Switch request sent to card.

The system has sent your redundancy switchover command to the associated card.

Switchover must be made from the primary WAN.

You cannot switch to a redundant WAN port from another redundant WAN port. You can only switch from a primary port to a redundant port.

Test function is not available.

The selected test is not available on the current card.

Test in progress. No changes from this screen.

You cannot change any settings in this screen while a card test is in progress.

Test is not available in slc96.

You cannot perform this test on an slc96 WAN port.

This option not available on INTF-2.

You cannot perform this action on the current Interface card.

timeout, no data received from server.

The user is attempting to download code, but the IMACS is unable to communicate to the server, or the server is not transferring any data.

Timeslot has different framing.

You cannot assign different subrate framing to the same WAN time slot. For example, if you have a port with b-5 framing on one WAN time slot, you cannot assign a different port with b-10 framing to that time slot.

transfer aborted.

A download operation has stopped, normally due to the user entering cntl-x.

Trunk Conditioning In Progress

The system is presently applying trunk conditioning

TS 16 cannot be used with v&s.

You cannot assign a voice circuit with signaling to time slot 16 of an E1 WAN port.

TS 16 is already in use.

You cannot assign time slot 16 of a CEPT E1 WAN port programmed for cas.

TS Connection must be specified.

You must specify a time slot connection for the WAN circuit.

TS(s) cannot be allocated.

You cannot assign a voice cross-connect to time slot 16 of a CEPT E1 WAN port.

Unit controlled by FEC.

The user card is controlled by forward error correction.

Units in pair must have the same source.

You must configure the Source parameter of User units on a FRAD card in pairs.

Upon activation CPU will reset, continue (y/n)?

A CPU switch or restart has been requested. Confirmation is required.

Voice CPU is not responding.

The voice CPU is not working. Power down the system, then power it up again.

WAN must be active (no loopback) to run BERT test.

You must turn off all WAN loopbacks before starting a BERT test on a WAN port.

WAN must have SLC format.

The WAN port must be configured for slc96.

Xconnect table can be accessed from primary WAN.

You cannot access the WAN cross-connect information from a redundant WAN port. Do this from a primary WAN port instead.

Appendix C

Pinouts

C.1 Introduction

This appendix describes the pinouts of the card connectors used to attach circuits and devices to the network. The number and type of connectors needed will vary with the card installed.

C.2 CPU Card

C.2.1 CPU Card (880770)

C.2.1.1 CPU External Connector and Pinouts

Figure C-1 shows the CPU card front panel, which has a single jack.



Figure C-1.CPU-7 Card Connector (880770)

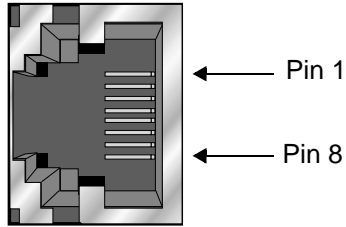

Figure C-2.RJ48 Ethernet Jack

Table C-1. RJ48 Ethernet Port Jack Pinouts

RJ48 Pin	Name	Definition	Direction
1	TXD+	Transmit Data	Output
2	TXD-	Transmit Data	Output
3	RXD+	Receive Data	Input
6	RXD-	Receive Data	Input

C.3 Interface Cards

C.3.1 INF-R EXT Card (893270)

C.3.1.1 INF-R External Connector and Pinouts

Figure C-3 shows the INF-R EXT card front panel, which has several jacks.

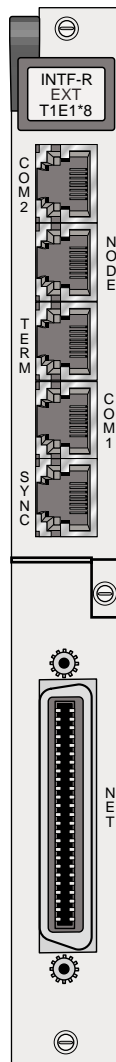

Figure C-3. INF-R EXT Card Connectors (893270)

Using the COM2 Port

The COM2 jack provides an RJ45 DTE connection to an external DTE device. Figure C-4 shows the COM2 jack pin locations, and Table C-2 lists the signal pinouts.

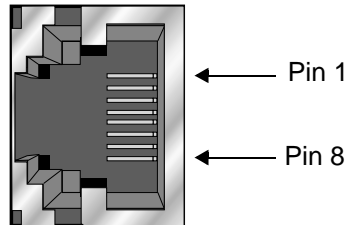

Figure C-4. RJ45 (COM2) Jack

Table C-2. RJ45 (COM2) Jack Signal Pinouts

RJ48 Pin	Designation	Function
1	RI	Ring Indicator (from DTE)
2	RLSD	Received Line Signal Detect (to DTE)
3	DTR	DTE Ready (from DTE)
4	GND	Signal Ground
5	RD	Receive Data (to DTE)
6	TD	Transmit Data (from DTE)
7	CTS	Clear to Send (to DTE)
8	RTS	Request to Send (from DTE)

Using the RJ-45 Node Port

The RJ-45 Node port allows you to activate external alarms that alert on-site personnel to critical situations. Using the ACO function will keep the alarm active until it is manually cleared from a control terminal.

Connect the NODE jack of the INF-E card to the external alarm equipment. This is another RJ-45 jack; it provides a set of form-C relay contacts to the external alarm equipment. Figure C-5 shows the pin locations on this jack, which are the same as the COM2 jack. Table C-3 lists the associated signal pinouts.

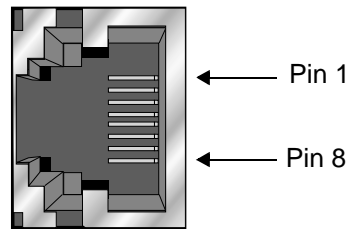

Figure C-5.RJ45 Node Jack

Table C-3. RJ45 (NODE) Jack Signal Pinouts

RJ48 Pin	Designation	Function
1	---	not used
2	---	not used
3	ANC	Alarm on Open Condition
4	ANO	Alarm on Closed Condition
5	ACOM	Alarm Common Lead (Source)
6	---	not used
7	---	not used
8	GND	Chassis Ground

The alarm interface is activated by the ACO setting. This will activate the device when a designated alarm occurs. See chapter on Alarms to review the conditions and settings necessary to enable this feature.

Connect pins 4 and 5 to provide an open relay contact to the external device upon occurrence of an alarm. Or, connect pins 3 and 5 for a relay contact closure upon alarm.

Using the Control Terminal Port

The RJ-45 Control Terminal Port allows you to connect the Integrated Access System to a local VT100-compatible terminal, which you can then use to control the system. This port is configured as a DCE interface.

Connect your local terminal to the TERM jack of the INF-R card. This is an RJ-45 jack in compliance with EIA-561. Figure C-6 shows the pin locations on this jack, and Table C-4 lists the signal pinouts.

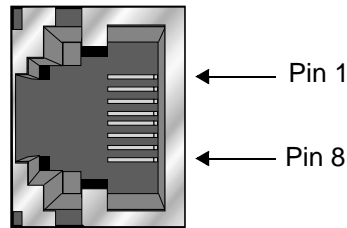

Figure C-6. RJ-45 (TERM) Local Interface Jack

Table C-4. RJ-45 (TERM) Jack Signal Pinouts

RJ-45 Pin	Function	Direction	9-pin connector
4	Signal Ground	N/A	5
5	Receive Data	To local terminal	3
6	Transmit Data	To access system	2
All other pins are open.			

Using the External Sync Port

The External Sync Port allows you to connect up to two external clocking sources from the external timing clock panel to an INF-E Card.

The external sync port is provided on the SYNC jack of the card. Connect the external clock sources to this jack. Figure C-7 shows the jack pin locations, and Table C-5 lists the signal pinouts.

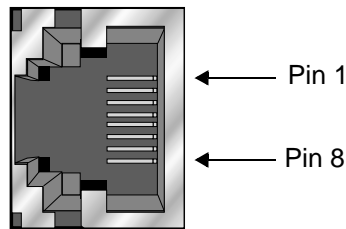

Figure C-7. RJ45 External Sync Jack

Table C-5. RJ45 External (SYNC) Jack Signal Pinouts

Pin Number	Designation	Description
1	R1	RING from Clock Source (Ext 1)
2	T1	TIP from Clock Source (Ext 1)
7	R2	RING from Clock Source (Ext 2)
8	T2	TIP from Clock Source (Ext 2)

Using the COM1 Management Port

Connect an external computer or other device to the jack for alarm reporting locally. This is a RJ45 connector. Figure C-8 shows the connector pin orientation, and Table C-6 lists the signal pinouts and directions for this DTE terminal device.

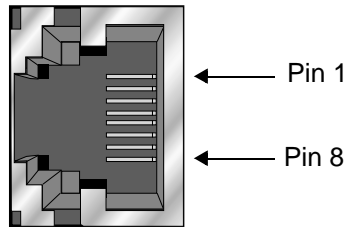

Figure C-8. Management Connector

Table C-6. Management Connector Signal Pinouts

Signal Name	RJ45 Pin	Function	Direction
RI	1	Ring Indicator	Input
DCD	2	Data Carrier Detect	Input
DTR	3	Data Terminal Ready	Output
S GND	4	Signal Ground	N/A
RD	5	Receive Data	Input
TD	6	Transmit Data	Output
CTS	7	Clear to Send	Input
RTS	8	Request to Send	Output

WAN Port Connections

The NET jack allows you to connect the system's WAN card ports to incoming and outgoing T1/E1 lines. This jack (Figure C-9) is a 50-pin, Amphenol-type connector. Table C-7 lists the signal pinouts for the NET jack.

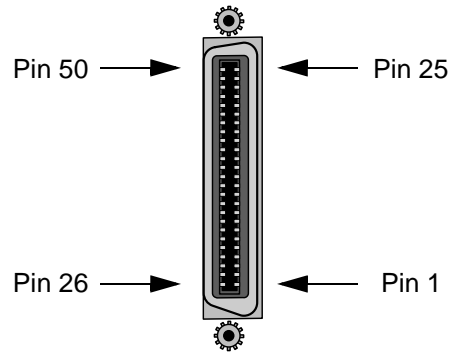

Figure C-9.NET Jack

Table C-7. NET Jack Signal Pinouts

WAN Link	Designation	Pin	Function
WAN 1-1	T1	47	Rx from Network
WAN 1-1	RI	22	Rx from Network
WAN 1-1	T	48	Tx to Network
WAN 1-1	R	23	Tx to Network
WAN 1-2	T1	44	Rx from Network
WAN 1-2	RI	19	Rx from Network
WAN 1-2	T	45	Tx to Network
WAN 1-2	R	20	Tx to Network
WAN 2-1	T1	41	Rx from Network
WAN 2-1	RI	16	Rx from Network
WAN 2-1	T	42	Tx to Network
WAN 2-1	R	17	Tx to Network
WAN 2-2	TI	38	Rx from Network
WAN 2-2	RI	13	Rx from Network
WAN 2-2	T	39	Tx to Network
WAN 2-2	R	14	Tx to Network
WAN 3-1	TI	35	Rx from Network
WAN 3-1	RI	10	Rx from Network
WAN 3-1	T	36	Tx to Network
WAN 3-1	R	11	Tx to Network
WAN 3-2	TI	32	Rx from Network
WAN 3-2	RI	7	Rx from Network
WAN 3-2	T	33	Tx to Network
WAN 3-2	R	8	Tx to Network
WAN 4-1	TI	29	Rx from Network
WAN 4-1	RI	4	Rx from Network
WAN 4-1	T	30	Tx to Network
WAN 4-1	R	5	Tx to Network
WAN 4-2	T1	26	Rx from Network
WAN 4-2	RI	1	Rx from Network
WAN 4-2	T	27	Tx to Network
WAN 4-2	R	2	Tx to Network

All other pins are open. Also WAN cards 1 through 4 are installed in slots W1 through W4, respectively, of all chassis models.

C.3.2 INF-R MODEM Card (893370)

C.3.2.1 INF-R MODEM Card External Connector and Pinouts

Figure C-10 shows the INF-R MODEM card front panel, which has several jacks.

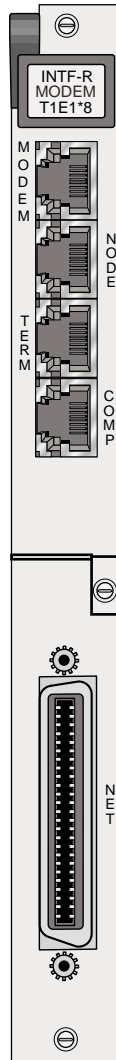

Figure C-10. INF-R Modem Card Jacks (893370)

Using the Modem Port

The internal modem of the INF-R modem card is an asynchronous, ITU-T V.22bis modem. It allows remote access to the terminal interface and automatic reporting of alarm messages to a remote device. Table C-8 lists the specifications of the modem.

Table C-8. Modem Specifications

Parameter	Rating
Compatibility	ITU-T V.22 bis
Modulation	16-point QAM
Line Interface	2-wire, 600 ohms
Approval	FCC Part 68
Equalization	Receive: automatic adaptive Transmit: fixed compromise
Receiver Sensitivity	ON to OFF threshold: -45 dBm OFF to ON threshold: -48 dBm
Dialing Mode	DTMF
Speed	2400 bps, asynchronous
Code Set	8-bit data, one stop bit, no parity
Ringer Equivalence	0.2 A
Transmit Level	-9.5 dBm

Connect the MODEM jack to a phone line, using a modular telephone cord. This is an RJ-45 jack which accepts an RJ-11 connector. The port uses only pins 4 (ground) 5 (Tip) and 6 (Ring). Figure C-11 shows the jack pin orientation.

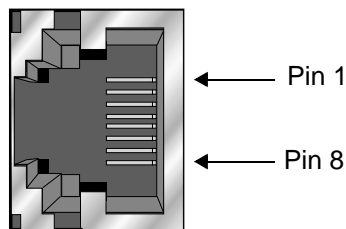

Figure C-11. MODEM Jack

The modem automatically answers incoming calls. A remote operator can press the <Enter> key to display the log-in screen. After entering a valid password, that operator has complete access to the user interface.

To disconnect, the remote operator logs off and then hangs up. The modem automatically resets and waits for the next call.

Using the RJ-45 Node Port

The RJ-45 Node port allows you to activate external alarms that alert on-site personnel to critical situations. Using the ACO function will keep the alarm active until it is manually cleared from a control terminal.

Connect the NODE jack of the INF+M card to the external alarm equipment. This is another RJ-45 jack; it provides a set of form-C relay contacts to the external alarm equipment. Figure C-12 shows the pin locations on this jack, which are the same as the COM2 jack. Table C-9 lists the associated signal pinouts.

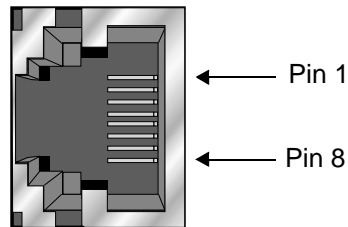

Figure C-12. RJ45 (NODE) Jack

Table C-9. RJ45 (NODE) Jack Signal Pinouts

RJ48 Pin	Designation	Function
1	---	not used
2	---	not used
3	ANC	Alarm on Closed Condition
4	ANO	Alarm on Open Condition
5	ACOM	Alarm Common Lead (Source)
6	---	not used
7	---	not used
8	GND	Chassis Ground

The alarm interface is activated by the ACO setting. This will activate the device when a designated alarm occurs. See chapter on Alarms to review the conditions and settings necessary to enable this feature.

Connect pins 4 and 5 to provide an open relay contact to the external device upon occurrence of an alarm. Or, connect pins 3 and 5 for a relay contact closure upon alarm.

Using the Control Terminal Port

The RS-232 Control Terminal Port allows you to connect the Integrated Access System to a local VT100-compatible terminal, which you can then use to control the system. This port is configured as a DCE interface.

Connect your local terminal to the TERM jack of the INF-E card. This is an RJ-45 jack in compliance with EIA-561. Figure C-13 shows the pin locations on this jack, and Table C-10 lists the signal pinouts.

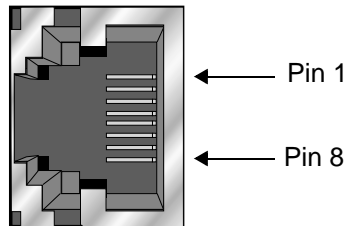

Figure C-13. RS232 (TERM) Local Interface Jack

Table C-10. RS232 (TERM) Jack Signal Pinouts

RS232 Pin	Function	Direction	9-pin connector
4	Signal Ground	N/A	5
5	Receive Data	To local terminal	3
6	Transmit Data	To access system	2
All other pins are open.			

Using the COMP Port

Connect an external computer or other device to the jack for alarm reporting locally. This is a RJ45 male connector. Figure C-14 shows the connector pin orientation, and Table C-11 lists the signal pinouts and directions.

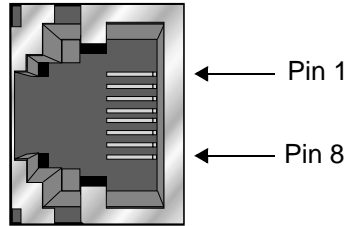

Figure C-14. Management Connector

Table C-11. Management Connector Signal Pinouts

Signal Name	DB-9 Pin	Function	Direction
RI	1	Ring Indicator	Input
DCD	2	Data Carrier Detect	Input
DTR	3	Data Terminal Ready	Output
S GND	4	Signal Ground	N/A
RD	5	Receive Data	Input
TD	6	Transmit Data	Output
CTS	7	Clear to Send	Input
RTS	8	Request to Send	Output

WAN Port Connections

The NET jack allows you to connect the system's WAN card ports to incoming and outgoing T1/E1 lines. This jack (Figure C-15) is a 50-pin, Amphenol-type connector. Table C-12 lists the signal pinouts for the NET jack.

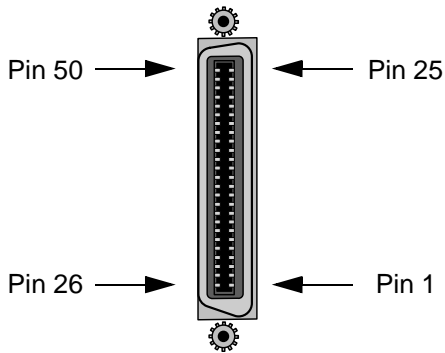

Figure C-15.NET Jack

Table C-12. NET Jack Signal Pinouts

WAN Link	Designation	Pin	Function
WAN 1-1	T1	47	Rx from Network
WAN 1-1	RI	22	Rx from Network
WAN 1-1	T	48	Tx to Network
WAN 1-1	R	23	Tx to Network
WAN 1-2	T1	44	Rx from Network
WAN 1-2	RI	19	Rx from Network
WAN 1-2	T	45	Tx to Network
WAN 1-2	R	20	Tx to Network
WAN 2-1	T1	41	Rx from Network
WAN 2-1	RI	16	Rx from Network
WAN 2-1	T	42	Tx to Network
WAN 2-1	R	17	Tx to Network
WAN 2-2	TI	38	Rx from Network
WAN 2-2	RI	13	Rx from Network
WAN 2-2	T	39	Tx to Network
WAN 2-2	R	14	Tx to Network
WAN 3-1	TI	35	Rx from Network
WAN 3-1	RI	10	Rx from Network
WAN 3-1	T	36	Tx to Network
WAN 3-1	R	11	Tx to Network
WAN 3-2	TI	32	Rx from Network
WAN 3-2	RI	7	Rx from Network
WAN 3-2	T	33	Tx to Network
WAN 3-2	R	8	Tx to Network
WAN 4-1	TI	29	Rx from Network
WAN 4-1	RI	4	Rx from Network
WAN 4-1	T	30	Tx to Network
WAN 4-1	R	5	Tx to Network
WAN 4-2	T1	26	Rx from Network
WAN 4-2	RI	1	Rx from Network
WAN 4-2	T	27	Tx to Network
WAN 4-2	R	2	Tx to Network

All other pins are open. Also WAN cards 1 through 4 are installed in slots W1 through W4, respectively, of all chassis models.

C.3.3 INF-R Card (893470)

The INF-R card does not have a modem and does not accept external synchronization clocks. In all other respects, it is functionally identical to the INF-R EXT and INF-R MODEM cards.

C.3.3.1 INF Card External Connector and Pinouts

Figure C-167 shows the INF-R card front panel, which has several jacks.

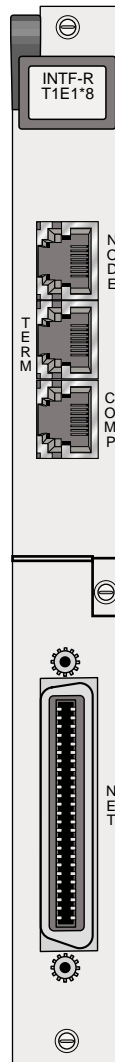

Figure C-16.INF-R Interface Card Jacks (893470)

The INF-R card uses faceplate connectors that are electrically similar to those of the INF-R EXT and INF-R MODEM cards previously described. The only exception is that the NODE jack of the INF card serves two purposes. It provides alarm relay contacts for external activation, and also provides data and clock interfaces for external alarm reporting systems.

Connect the INF-R card to the external local terminal, alarm reporting system or printer, and T1/E1 network, as previously described for the other Interface cards. Also connect the alarm relay contacts and synchronization clocks to the NODE jack. Table C-13 lists the signal pinouts for that jack.

Using the RJ-45 Node Port

The RJ-45 Node port allows you to activate external alarms that alert on-site personnel to critical situations. Using the ACO function will keep the alarm active until it is manually cleared from a control terminal.

Connect the NODE jack of the INF card to the external alarm equipment. This is another RJ-45 jack; it provides a set of form-C relay contacts to the external alarm equipment. Figure C-17 shows the pin locations on this jack, which are the same as the COM2 jack. Table C-13 lists the associated signal pinouts.

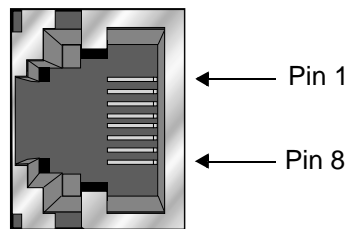

Figure C-17.RJ45 (NODE) Jack

Table C-13. RJ45 (NODE) Jack Signal Pinouts

RJ48 Pin	Designation	Function
1	---	not used
2	---	not used
3	ANC	Alarm on Closed Condition
4	ANO	Alarm on Open Condition
5	ACOM	Alarm Common Lead (Source)
6	---	not used
7	---	not used
8	GND	Chassis Ground

The alarm interface is activated by the ACO setting. This will activate the device when a designated alarm occurs. See chapter on Alarms to review the conditions and settings necessary to enable this feature.

Connect pins 4 and 5 to provide an open relay contact to the external device upon occurrence of an alarm. Or, connect pins 3 and 5 for a relay contact closure upon alarm.

Using the Control Terminal Port

The RS-232 Control Terminal Port allows you to connect the Integrated Access System to a local VT100-compatible terminal, which you can then use to control the system. This port is configured as a DCE interface.

Connect your local terminal to the TERM jack of the INF-E card. This is an RJ-45 jack in compliance with EIA-561. Figure C-18 shows the pin locations on this jack, and Table C-14 lists the signal pinouts.

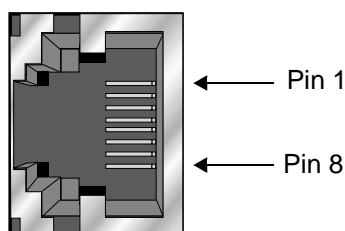

Figure C-18. RS232 (TERM) Local Interface Jack

Table C-14. RS232 (TERM) Jack Signal Pinouts

RS232 Pin	Function	Direction	9-pin connector
4	Signal Ground	N/A	5
5	Receive Data	To local terminal	3
6	Transmit Data	To access system	2
All other pins are open.			

Using the COMP Port

Connect an external computer or other device to the jack for alarm reporting locally. This is a RJ45 male connector. Figure C-14 shows the connector pin orientation, and Table C-11 lists the signal pinouts and directions.

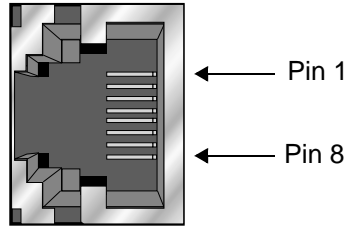

Figure C-19. Management Connector

Table C-15. Management Connector Signal Pinouts

Signal Name	DB-9 Pin	Function	Direction
RI	1	Ring Indicator	Input
DCD	2	Data Carrier Detect	Input
DTR	3	Data Terminal Ready	Output
S GND	4	Signal Ground	N/A
RD	5	Receive Data	Input
TD	6	Transmit Data	Output
CTS	7	Clear to Send	Input
RTS	8	Request to Send	Output

WAN Port Connections

The NET jack allows you to connect the system's WAN card ports to incoming and outgoing T1/E1 lines. This jack (Figure C-15) is a 50-pin, Amphenol-type connector. Table C-12 lists the signal pinouts for the NET jack.

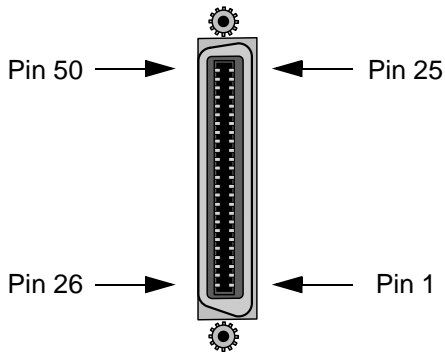

Figure C-20.NET Jack

Table C-16. NET Jack Signal Pinouts

WAN Link	Designation	Pin	Function
WAN 1-1	T1	47	Rx from Network
WAN 1-1	RI	22	Rx from Network
WAN 1-1	T	48	Tx to Network
WAN 1-1	R	23	Tx to Network
WAN 1-2	T1	44	Rx from Network
WAN 1-2	RI	19	Rx from Network
WAN 1-2	T	45	Tx to Network
WAN 1-2	R	20	Tx to Network
WAN 2-1	T1	41	Rx from Network
WAN 2-1	RI	16	Rx from Network
WAN 2-1	T	42	Tx to Network
WAN 2-1	R	17	Tx to Network
WAN 2-2	TI	38	Rx from Network
WAN 2-2	RI	13	Rx from Network
WAN 2-2	T	39	Tx to Network
WAN 2-2	R	14	Tx to Network
WAN 3-1	TI	35	Rx from Network
WAN 3-1	RI	10	Rx from Network
WAN 3-1	T	36	Tx to Network
WAN 3-1	R	11	Tx to Network
WAN 3-2	TI	32	Rx from Network
WAN 3-2	RI	7	Rx from Network
WAN 3-2	T	33	Tx to Network
WAN 3-2	R	8	Tx to Network
WAN 4-1	TI	29	Rx from Network
WAN 4-1	RI	4	Rx from Network
WAN 4-1	T	30	Tx to Network
WAN 4-1	R	5	Tx to Network
WAN 4-2	T1	26	Rx from Network
WAN 4-2	RI	1	Rx from Network
WAN 4-2	T	27	Tx to Network
WAN 4-2	R	2	Tx to Network

All other pins are open. Also WAN cards 1 through 4 are installed in slots W1 through W4, respectively, of all chassis models.

C.4 Alarm Cards

C.4.1 ALR 4+4 Card (840160)

C.4.1.1 ALR 4+4 Card External Connectors and Pinouts

The ALR 4+4 Card has a 50-pin Amphenol female connector (jack) on its faceplate. Figure C-21 shows the jack, and Table C-17 shows the pinouts for the inbound sensor alarms and outbound internal alarms.

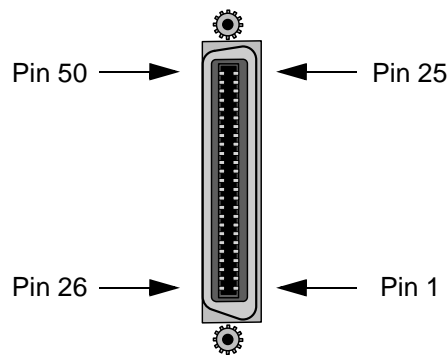

Figure C-21. ALR 4+4 Card Jack

Table C-17. ALR 4+4 Card Jack Pinouts

Inbound Alarms			Outbound Alarms			
Sensor	Designation	Pin	Relay	Source	Norm Close	Norm Open
1	R1	1	R1(A)	7	6	8
	T1	26	R1(B)	32	31	33
2	R2	2	R2(A)	11	10	12
	T2	27	R2(B)	36	35	37
3	R3	3	R3(A)	15	14	16
	T3	28	R3(B)	40	39	41
4	R4	4	R4(A)	19	18	20
	T4	29	R4(B)	44	43	45

C.5 E&M Cards

C.5.1 E&M 2W*8 Card (810860)

C.5.1.1 E&M 2W*8 Card External Connectors and Pinouts

The card has a 50-pin, Amphenol-type jack on its faceplate. Figure C-22 shows this jack, and Table C-18 lists the signal pinouts.

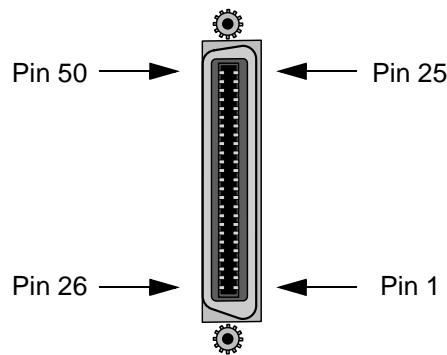

Figure C-22.E&M 2W*8 Card Jack

Table C-18. E&M 2W*8 Card Jack Pinouts

Port	Designation	Pin	Port	Designation	Pin
1	T	26	5	T	38
1	R	1	5	R	13
1	E	28	5	E	40
1	M	3	5	M	15
2	T	29	6	T	41
2	R	4	6	R	16
2	E	31	6	E	43
2	M	6	6	M	18
3	T	32	7	T	44
3	R	7	7	R	19
3	E	34	7	E	46
3	M	9	7	M	21
4	T	35	8	T	47
4	R	10	8	R	22
4	E	37	8	E	49
4	M	12	8	M	24
All channels	SB	50	All channels	SG	25

C.5.2 E&M 4W*8ER Card (811960)

C.5.2.1 E&M 4W*8ER Card External Connectors and Pinouts

The card has a 50-pin, Amphenol-type jack on its faceplate. Figure C-23 shows this jack, and Table C-19 lists the signal pinouts.

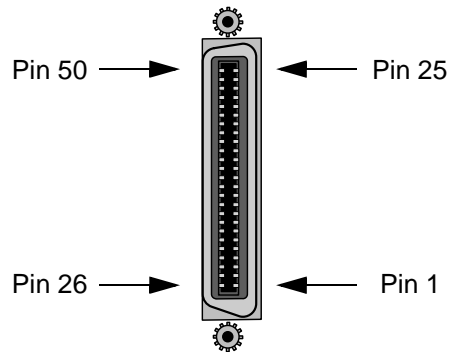

Figure C-23.E&M 4W*8ER Card Jack

Table C-19. E&M 4W*8ER Card Jack Pinouts

Port	Designation	Pin	Port	Designation	Pin
1	T	26	5	R	13
1	R	1	5	T1	39
1	T1	27	5	R1	14
1	R1	2	5	E	40
1	E	28	5	M	15
1	M	3	6	T	41
2	T	29	6	R	16
2	R	4	6	T1	42
2	T1	30	6	R1	17
2	R1	5	6	E	43
2	E	31	6	M	18
2	M	6	7	T	44
3	T	32	7	R	19
3	R	7	7	T1	45
3	T1	33	7	R1	20
3	R1	8	7	E	46
3	E	34	7	M	21
3	M	9	8	T	47
4	T	35	8	R	22
4	R	10	8	T1	48
4	T1	36	8	R1	23
4	R1	11	8	E	49
4	E	37	8	M	24
4	M	12	All channels	SB	50
5	T	38	All channels	SG	25

C.6 FXS Cards

C.6.1 FXS 2W*8-6 Card (812960)

C.6.1.1 FXS 2W*8-6 Card External Connectors and Pinouts

The FXS 2W*8-6 Card has a 50-pin Amphenol jack on its faceplate. Figure C-24 shows this jack, and Table C-20 lists the signal pinouts.

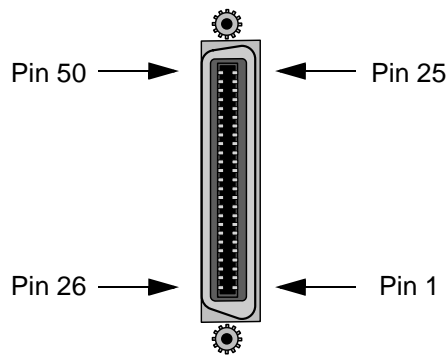

Figure C-24.FXS 2W*8-6 Card Jack

Table C-20. FXS 2W*8-6 Card Jack Pinouts

Port #	Designation	Pin #
1	T	26
1	R	1
2	T	29
2	R	4
3	T	32
3	R	7
4	T	35
4	R	10
5	T	38
5	R	13
6	T	41
6	R	16
7	T	44
7	R	19
8	T	47
8	R	22

All other pins are open.

C.7 FXO Cards

C.7.1 FXO 2W*8-6 Card (813970)

C.7.1.1 FXO 2W*8-6 Card External Connector and Pinouts

The FXO 2W*8-6 card has a 50-pin Amphenol jack on its faceplate. Figure C-25 shows this jack, and Table C-21 lists the signal pinouts.

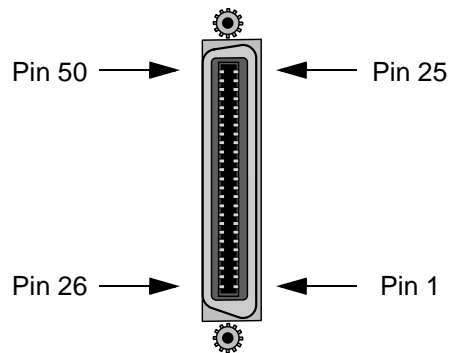

Figure C-25.FXO 2W*8-6 Card Jack

Table C-21. FXO 2W*8-6 Card Jack Pinouts

Port #	Designation	Pin #
1	T	26
1	R	1
2	T	29
2	R	4
3	T	32
3	R	7
4	T	35
4	R	10
5	T	38
5	R	13
6	T	41
6	R	16
7	T	44
7	R	19
8	T	47
8	R	22
All other pins are open.		

C.8 HSU Cards

C.8.1 Two-Port HSU530/35 Card (820260)

C.8.1.1 Two-Port HSU Card External Connectors and Pinouts

The two-port HSU 530/35 Card has two DB-25 jacks for external connections, as shown in Figure C-26. The connectors have the following characteristics:

The card jacks are wired as RS-530 interfaces. Figure C-27 shows their pin locations, and Table C-22 lists the signal pinouts.

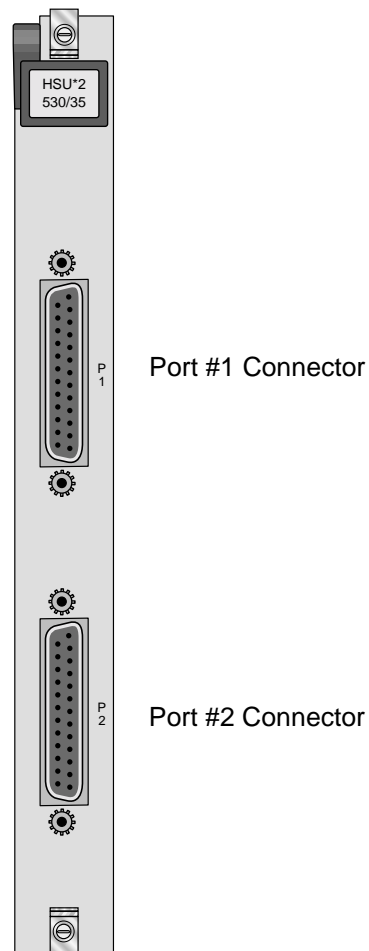

Figure C-26. Two-Port HSU 530/35 Front Panel Connectors (820260)

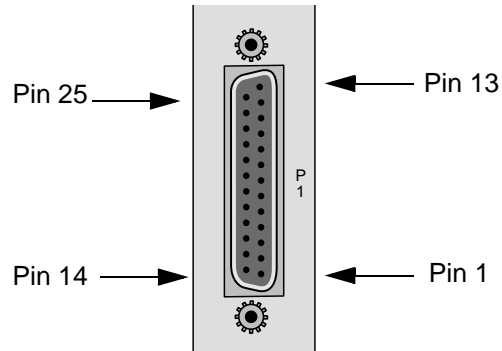

Figure C-27. Two-Port HSU 530/35 Jack Pin Orientation

Table C-22. Two-Port HSU 530/35 Jack Pinouts

Pin	Function	Direction
1	Cable Shield	--
2	Send Data A	Input
3	Receive Data A	Output
4	RTS A	Input
5	CTS A	Output
6	DCE Ready	Output
7	Signal Common	--
8	RR/RLSD A	Output
9	Receive Timing B	Output
10	RR/RLSD B	Output
11	Terminal Timing B	Input
12	Send Timing B	Output
13	CTS B	Output
14	Send Data B	Input
15	Send Timing A	Output
16	Receive Data B	Output
17	Receive Timing A	Output
18	Local Loopback	Input
19	RTS B	Input
20	DTE Ready	Input
21	Remote Loopback	Input
22	Incoming Call	Output
23	Receive Common	--
24	Terminal Timing A	Input
25	Test Mode	Output

C.8.2 HSU-T V11 Card (820360)

C.8.2.1 HSU-T V11 Card External Connectors and Pinouts

The HSU-T V11 Card has two DB-25 connectors, as shown in Figure C-28. The connector pin locations are shown in Figure C-26, and the jack signal pinouts are given in Table C-23.

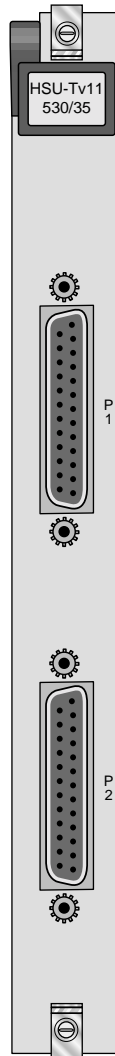

Figure C-28.HSU-T V11 Card Front Panel Connectors (820360)

Table C-23. HSU-T V11 Jack Pinouts

Pin	Function	DCE Mode	DTE Mode
1	Cable Shield	--	--
2	Send Data A	Input	Input
3	Receive Data A	Output	Output
4	RTS A	Input	Input
5	CTS A	Output	Input
6	DCE Ready	Output	Output
7	Signal Common	--	--
8	RR/RLSD A	Output	Output
9	Receive Timing B	Output	Input
10	RR/RLSD B	Output	Output
11	Terminal Timing B	Input	Input
12	Send Timing B	Output	Output
13	CTS B	Output	Input
14	Send Data B	Input	Input
15	Send Timing A	Output	Output
16	Receive Data B	Output	Input
17	Receive Timing A	Output	Output
18	Local Loopback	Input	Input
19	RTS B	Input	Input
20	DTE Ready	Input	Input
21	Remote Loopback	Input	Input
22	Incoming Call	Output	Output
23	Receive Common	--	--
24	Terminal Timing A	Input	Input
25	Test Mode	Output	

C.8.3 HSU 35 Card (821260)

C.8.3.1 HSU 35 Card External Connectors and Pinouts

The HSU 35 Card has two DB-25 jacks for V.35 connections to the external CPE. Figure C-29 shows their pin locations, and Table C-24 lists the signal pinouts.

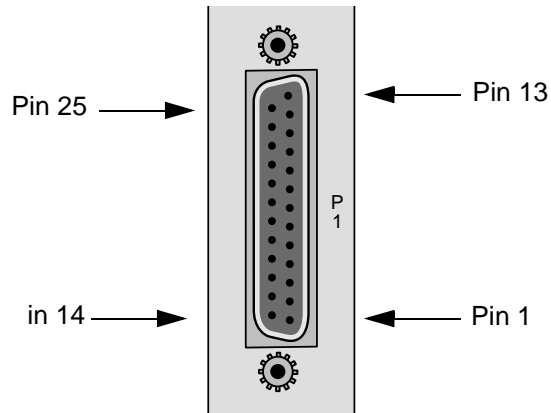

Figure C-29.HSU 35 Card Jack Pin Orientation

Table C-24. HSU 35 Card Jack Signal Pinouts

Pin	Function	DCE Mode	DTE Mode
1	Cable Shield	---	---
4	RTS	Input	Input
5	CTS	Output	Input
6	DSR	Output	Output
7	Signal Ground	---	---
8	RLSD	Output	Output
9	SD B	Input	Input
10	SD A	Input	Input
11	SCTE B	Input	Input
12	SCTE A	Input	Input
13	RD B	Output	Output
14	RD A	Output	Output
17	SCR B	Output	Input
18	SCR A	Output	Input
24	SCT B	Output	Output
25	SCT A	Output	Output

C.8.4 HSU-AD 530/35 Card (821360)

C.8.4.1 HSU-AD 530/35 Card External Connectors and Pinouts

The HSU-AD 530/35 Card has two DB-26 jacks for RS-530 or V.35 connections, plus two DB-15 female connectors for RS-366 dialing connections in an ISDN environment. Figure C-30 shows these jacks.

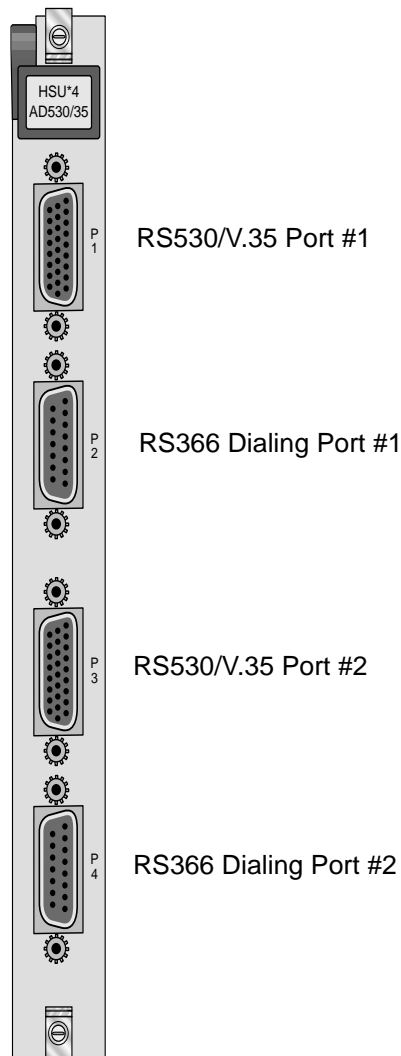

Figure C-30.HSU-AD 530/35 Card Jacks (821360)

RS530/V.35 Jacks

The RS-530/V.35 jacks allow you to connect the card to two external CPE devices. The electrical configuration of each jack is switch-selectable on the main board. Figure C-31 shows the jack pin locations, and Table C-25 lists the signal pinouts.

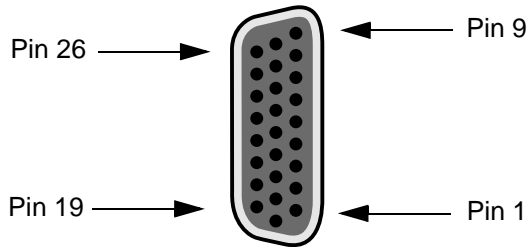

Figure C-31.HSU-AD 530/35 Card Jack Pin Orientation

Table C-25. HSU-AD 530/35 Card Jack Signal Pinouts

Pin #	Function	Direction
1	Cable Shield	--
2	Send Data A	Input
3	Receive Data A	Output
4	RTS A	Input
5	CTS A	Output
6	DCE Ready	Output
7	Signal Common	--
8	RR/RLSD A	Output
9	Receive Timing B	Output
10	RR/RLSD B	Output
11	Terminal Timing B	Input
12	Send Timing B	Output
13	CTS B	Output
14	Send Data B	Input
15	Send Timing A	Output
16	Receive Data B	Output
17	Receive Timing A	Output
18	Local Loopback	Input
19	RTS B	Input
20	DTE Ready	Input
21	Remote Loopback	Input
22	Incoming Call	Output
23	Ext Rcv Clock	Input
24	Terminal Timing A	Input
25	Test Mode	Output
26	Ext Rcv Clock	Input

RS-366 Jacks

The HSU-AD 530/35 Card RS-366 jacks allow you to connect the system to external CPE devices for RS-366 dialing. These are DB-15 jacks with the pin locations shown in Figure C-32. Table C-26 lists the signal pinouts.

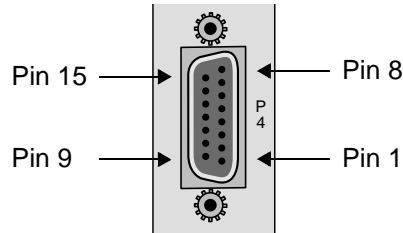

Figure C-32. HSU-AD 530/35 Card RS-366 Jack Pin Orientation

Table C-26. HSU-AD 530/35 Card RS-366 Jack Pinouts

Pin	Function	Direction
1	Cable Shield	--
2	DPR	Input
3	ACR	Output
4	CRQ	Input
5	PND	Output
6	PWI	Output
7	Signal Gnd	--
8	DSC	Output
9	NB1	Input
10	NB2	Input
11	NB4	Input
12	NB8	Input
13	REC COM	--
14	SEND COM	--
15	DLO	Output

C.8.5 HSU-T V35 Card (821460)

C.8.5.1 HSU-T V35 Card External Connectors and Pinouts

The HSU-T V35 Card has two DB-25 female connectors, which are shown in Figure C-33. Figure C-34 shows the connector pin locations, and Table C-27 lists the signal pinouts.

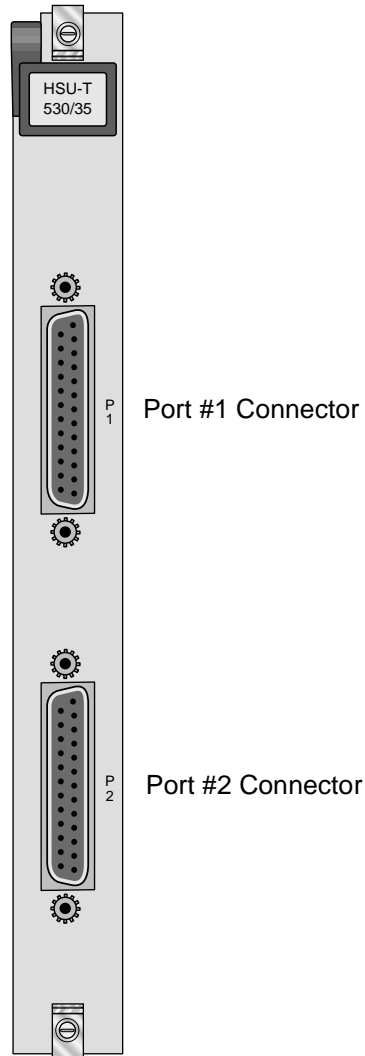

Figure C-33.HSU-T V35 Card Front Panel Connectors (821460)

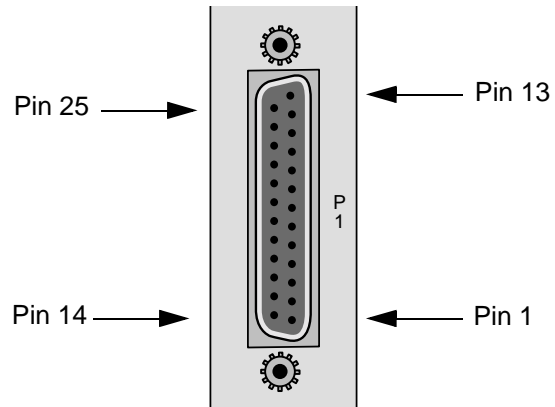

Figure C-34.HSU-T V35 Card Jack Pin Orientation

Table C-27. HSU-T V35 Card Jack Pinouts

Pin	MODE DCE¹	MODE DTE²
1	Shield Ground	Shield Ground
4	RTS	CTS
5	CTS	RTS
6	DSR	DTR
7	Signal Ground	Signal Ground
8	RR/RLSD	RLB
9	TD B	RD B
10	TD A	RD A
11	SCTE B	SCT B
12	SCTE A	SCT A
13	RD B	TD B
14	RD A	TD A
15	---	---
16	---	---
17	SCR B	---
18	SCR A	---
19	TM	LLB
20	DTR	DSR
21	RLB	RR/RLSD
22	LLB	TM
24	SCT B	SCTE B
25	SCT A	SCTE A

1. Use cable P/N 000-01260F if HSU-T V35 card is set to DCE mode.
2. Use cable P/N 000-01260M if HSU-T V35 card is set to DTE mode.

C.8.6 Four-Port HSU 530/35 Card (821570)

C.8.6.1 Four-Port HSU 530/35 Card External Connectors and Pinouts

The four-port HSU 530/35 Card has four DB-26 female connectors, as shown in Figure C-35.

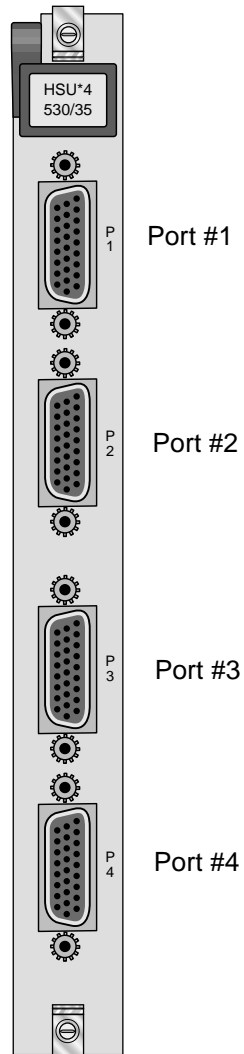

Figure C-35. Four-Port HSU 530/35 Card Jacks (821560)

The RS-530/V.35 connectors allow you to connect the system to external data devices. Figure C-31 shows the connector pin orientation, and Table C-28 lists the signal pinouts.

Table C-28. Four-Port HSU 530/35 Jack Pinouts

Pin	Function	Direction
1	Cable Shield	--
2	Send Data A	Input
3	Receive Data A	Output
4	RTS A	Input
5	CTS A	Output
6	DCE Ready	Output
7	Signal Common	--
8	RR/RLSD A	Output
9	Receive Timing B	Output
10	RR/RLSD B	Output
11	Terminal Timing B	Input
12	Send Timing B	Output
13	CTS B	Output
14	Send Data B	Input
15	Send Timing A	Output
16	Receive Data B	Output
17	Receive Timing A	Output
18	Local Loopback	Input
19	RTS B	Input
20	DTE Ready	Input
21	Remote Loopback	Input
22	Incoming Call	Output
23	Ext Rcv Clock	Input
24	Terminal Timing A	Input
25	Test Mode	Output
26	Ext Rcv Clock	Input

C.8.7 Four-Port HSU*4E 530/35 SS Card (821660)

C.8.7.1 Four-Port HSU*4E 530/35 SS Card Connector Pinouts

The four-port HSU*4E 530/35 SS Card has four DB-26 female connectors, as shown in Figure C-36.

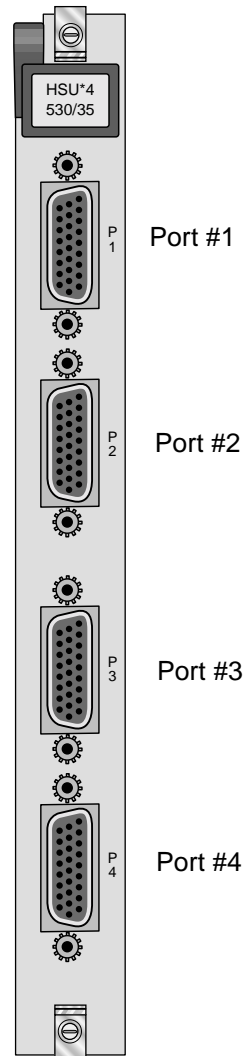

Figure C-36. Four-Port HSU*4E 530/35 SS Card Jacks (821660)

The RS-530/V.35 connectors allow you to connect the system to external data devices. Figure C-31 shows the connector pin orientation, and Table C-29 lists the signal pinouts.

Table C-29. Four-Port HSU*4E 530/35 SS Jack Pinouts

Pin	Function	Direction
1	Cable Shield	--
2	Send Data A	Input
3	Receive Data A	Output
4	RTS A	Input
5	CTS A	Output
6	DCE Ready	Output
7	Signal Common	--
8	RR/RLSD A	Output
9	Receive Timing B	Output
10	RR/RLSD B	Output
11	Terminal Timing B	Input
12	Send Timing B	Output
13	CTS B	Output
14	Send Data B	Input
15	Send Timing A	Output
16	Receive Data B	Output
17	Receive Timing A	Output
18	Local Loopback	Input
19	RTS B	Input
20	DTE Ready	Input
21	Remote Loopback	Input
22	Incoming Call	Output
23	Ext Rcv Clock	Input
24	Terminal Timing A	Input
25	Test Mode	Output
26	Ext Rcv Clock	Input

C.8.8 HSU Card Cables

Table C-30, Table C-31, and Table C-32 represent a matrix used for connecting cables to HSU Cards for DTE and DCE transmit clocking. The following HSU Cards apply (820260, 820360, 821260, 821360, 821460, 821560 and 821660).

Table C-30. HSU to Cable Matrix (To DTE Clock)

HSU CARD	TO A DTE THAT ACCEPTS CLOCK				
	RS232	RS366	RS449	RS530	V.35
820260 NO SWITCHES	1252/1221*		1212F/M	1204F/M	1203F/1251
820260 WITH SWITCHES	1252/1221*		1212F/M	1204F/M	1261F/M
820360 DCE	1252/1221*		1212F/M	1204F/M	1261F/M
820360 DTE					
821260					1203F/M
821360/821560/821660	1264F/1253**	1206F	1265F/M	1264F/M	1263F/M
821460 DCE					1260F/M
821460 DTE					
2 PORT EXT. CABLES	1221			1222	1224
4 PORT EXT. CABLES				1269	1268

*820260/820360 Switches set to RS-530 and 1252 Connected to HSU Card

**The 1253 Connects to the end of the 1264F Cable

Table C-31. HSU to Cable Matrix (To DCE Clock)

HSU CARD	TO A DCE THAT ACCEPTS CLOCK		
	RS449	RS530	V.35
820260 NO SWITCHES	1212X	1204X	1203X/1251
820260 WITH SWITCHES	1212X	1204X	1261X
820360 DCE	1212X	1204X	1261X
820360 DTE			
821260			1203X
821360/821560/821660	1265X	1264X	1263X
821460 DCE			1203X
821460 DTE			
2 PORT EXT. CABLES		1222	1224
4 PORT EXT. CABLES		1269	1268

Table C-32. HSU to Cable Matrix (DCE Provides Clock)

HSU CARD	DCE PROVIDES CLOCK		
	RS530	V.35	RS449
820260 NO SWITCHES			
820260 WITH SWITCHES			
820360 DCE			
820360 DTE	1204X		1211
821260			
821360/821560/821660			
821460 DCE			
821460 DTE		1260F/M	
2 PORT EXT. CABLES			
4 PORT EXT. CABLES			

C.9 OHSU Cards

C.9.1 OHSU 2-port Card (823760)

C.9.1.1 OHSU Card External Connector and Pinouts

The OHSU Card has four optical jacks on its faceplate for connections to the external data devices. Figure C-37 shows these jacks, and Table C-35 lists the signal pinouts.



Figure C-37. Fiber ST connectors (823760)

Table C-33. OHSU 2-port Card ST connector designation

Connector	Definition
Port 1 RX	Receive Port 1
Port 1 TX	Transmit Port 1
Port 2 RX	Receive Port 2
Port 2 TX	Transmit Port 2

C.9.2 OHSU 4-Port Card (823870 / 823875)

C.9.2.1 OHSU Card External Connector and Pinouts

The OHSU 4-port Card has eight optical jacks on its faceplate for connections to the external data devices. Figure C-37 shows these jacks, and Table C-35 lists the signal pinouts.

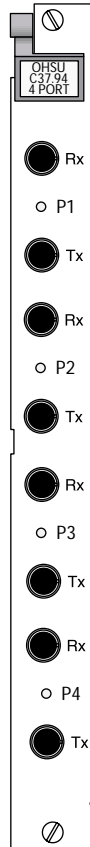

Figure C-38. Fiber ST connectors (823870 / 823875)

Table C-34. OHSU Card ST connector designation

Connector	Definition
Port 1 RX	Receive Port 1
Port 1 TX	Transmit Port 1
Port 2 RX	Receive Port 2
Port 2 TX	Transmit Port 2
Port 3 RX	Receive Port 3
Port 3 TX	Transmit Port 3
Port 4 RX	Receive Port 4
Port 4 TX	Transmit Port 4

C.10 SRU Cards

C.10.1 SRU 232*10 Card (822060)

C.10.1.1 SRU 232*10 Card External Connector and Pinouts

The SRU 232*10 Card has ten modular jacks on its faceplate for connections to the external data devices. Figure C-39 shows these jacks, and Table C-35 lists the signal pinouts.

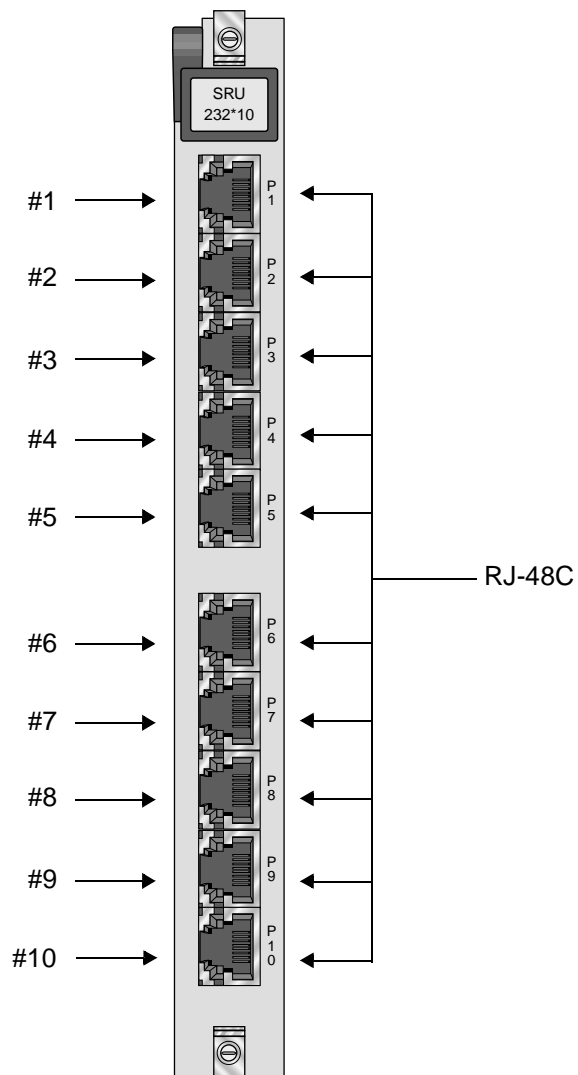

Figure C-39.SRU 232*10 Card Jacks (822060)

Table C-35. SRU 232*10 Card Jack Pinouts

Connector Pin	Signal Name	Direction
1	RCLK	To DTE
2	RLSD	To DTE
3	TCLK	To DTE
4	GND	N/A
5	RD	To DTE
6	TD	From DTE
7	CTS	To DTE
8	RTS	From DTE

C.10.2 SRU 232*10 C&D Bus Card (822160)

C.10.2.1 SRU 232*10 C&D Bus Card External Connector and Pinouts

The SRU 232*10 C&D Bus Card has ten modular jacks on its faceplate for connections to the external data devices. Figure C-39 shows these jacks, and Table C-35 lists the signal pinouts.

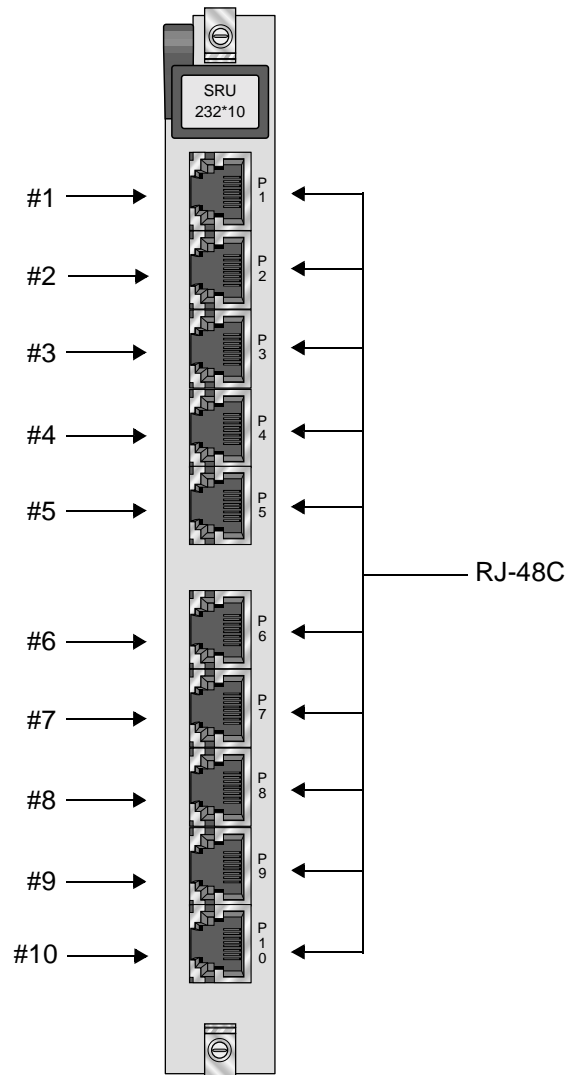

Figure C-40.SRU 232*10 C&D Bus Card Jacks (822160)

Table C-36. SRU 232*10 C&D Bus Card Jack Pinouts

Connector Pin	Signal Name	Direction
1	RCLK	To DTE
2	RLSD	To DTE
3	TCLK	To DTE
4	GND	N/A
5	RD	To DTE
6	TD	From DTE
7	CTS	To DTE
8	RTS	From DTE

C.10.3 SRU-LD*10 Card (822560 / 822570)

C.10.3.1 SRU-LD*10 Card External Connector and Pinouts

The SRU-LD*10 Card has ten modular jacks on its faceplate for connections to the external data devices. Figure C-41 shows these jacks, and Table C-37 lists the signal pinouts.

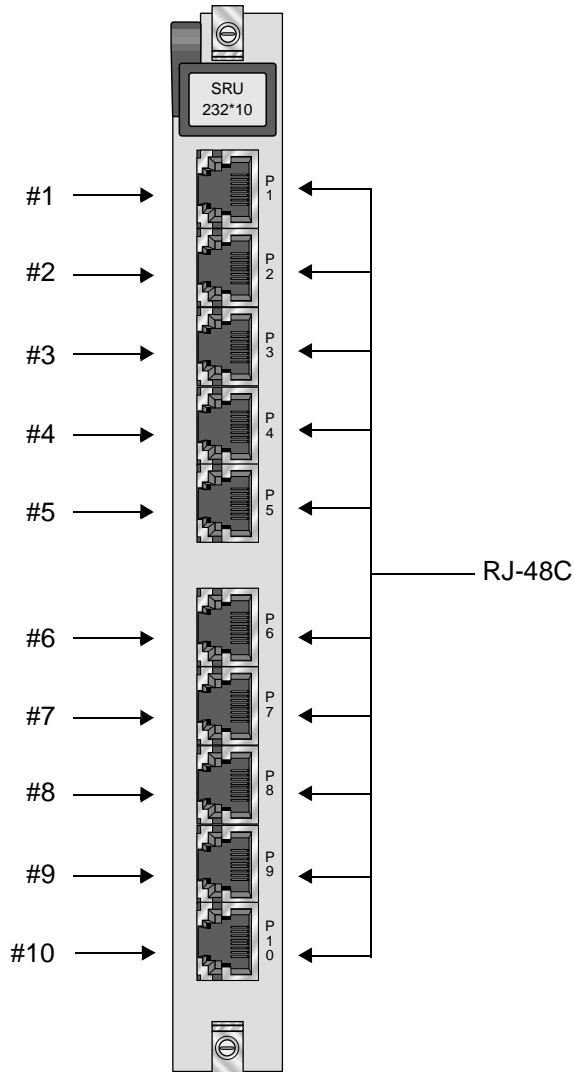

Figure C-41. SRU-LD*10 Card Jacks (822560 / 822570)

Table C-37. SRU-LD*10 Card Jack Pinouts

Connector Pin	Signal Name	Direction
1	RCLK	To DTE
2	RLSD	To DTE
3	TCLK	To DTE
4	GND	N/A
5	RD	To DTE
6	TD	From DTE
7	CTS	To DTE
8	RTS	From DTE

C.11 OCU-DP Cards

C.11.1 OCU-DP 2 Card (8249)

C.11.1.1 OCU-DP 2 Card External Connectors and Pinouts

Install the OCU-DP 2 Card into any of the same slots as the OCU-DP 5 Card. The OCU-DP 2 Card has two modular RJ-48 jacks. Figure C-42 shows these jacks, and Table C-38 lists the signal pinouts for each jack.

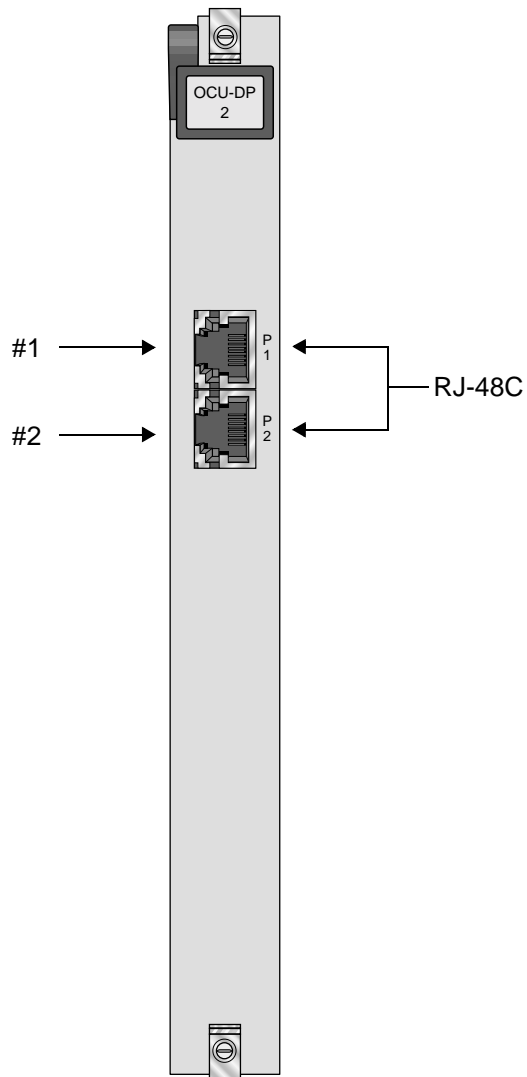

Figure C-42.OCU-DP 2 Card Jacks

Table C-38. OCU-DP 2 Jack Signals Pinouts

RJ-48 Pin	Signal Name	Direction
1	R1	input
2	T1	input
3	--	--
4	--	--
5	--	--
6	--	--
7	T	output
8	R	output

C.11.2 OCU-DP 5 Card (824160)

C.11.2.1 OCU-DP 5 Card External Connectors and Pinouts

The OCU-DP 5 Card has five standard modular jacks. Figure C-43 shows the card jacks, and Table C-39 lists the signal pinouts for each jack.

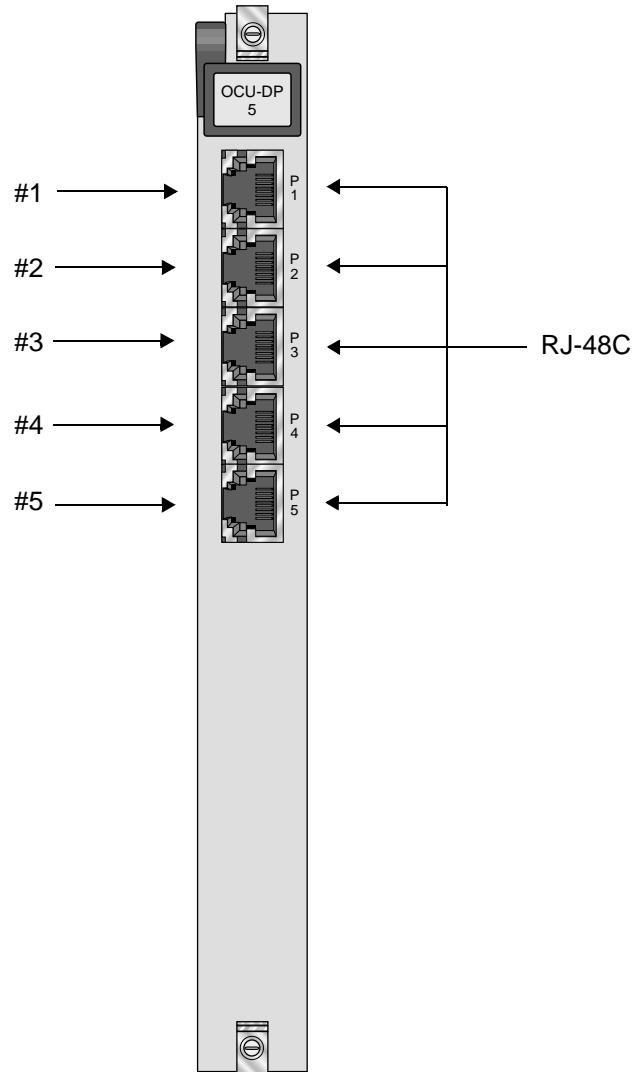

Figure C-43.OCU-DP 5 Card Jacks (842160)

Table C-39. OCU-DP 5 Jack Signals Pinouts

RJ-48 Pin	Signal Name	Direction
1	R1	input
2	T1	input
3	--	--
4	--	--
5	--	--
6	--	--
7	T	output
8	R	output

C.11.3 OCU-DP 10 Card (824660)

C.11.3.1 OCU-DP 10 Card External Connectors and Pinouts

Figure C-44 shows the 10 RJ-48C jacks, and Table C-43 lists the signal pinouts for each jack.

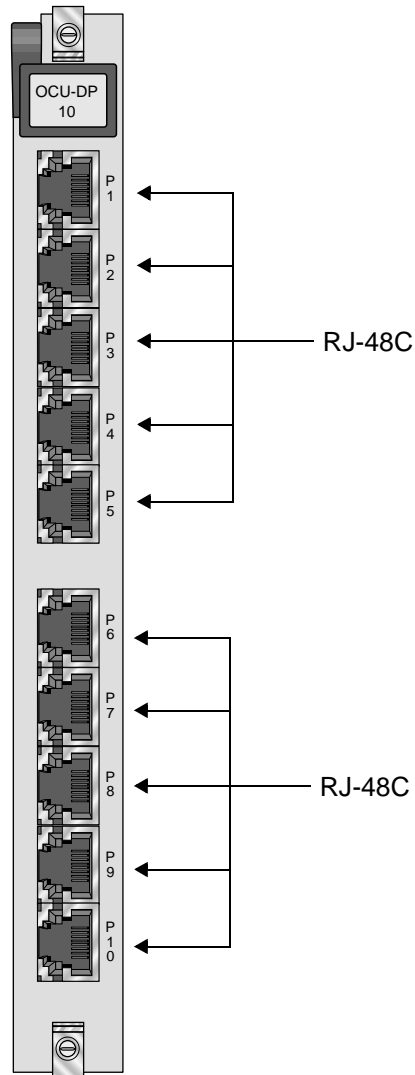

Figure C-44.OCU-DP 10 Card Jacks (824660)

Table C-40. OCU-DP 10 Jack Signals Pinouts

RJ-48 Pin	Signal Name	Direction
1	R1	input
2	T1	input
3	--	--
4	--	--
5	--	--
6	--	--
7	T	output
8	R	output

C.12 DS0-DP Cards

C.12.1 DS0-DP 4 Card (825460)

C.12.1.1 DS0-DP 4 Card External Connector and Pinouts

The DS0-DP 4 Card has four standard DB-15 jacks that correspond to the four data ports assignable on each card. Figure C-45 shows the card jacks and Table C-41 lists the signal pinouts for these jacks.

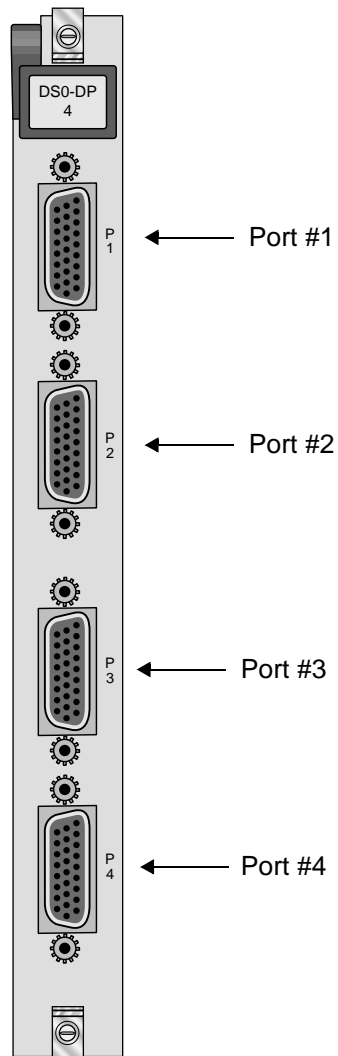

Figure C-45.DS0-DP 4 Card Jacks (825460)

Table C-41. DS0-DP 4 Card Jack Pinouts

Pin	Description	CLK	Direction	Mode
1	GND	---	---	
2	N/C	---	---	
3	XMT CLK A	int	To DTE	G.703 Contradirectional
4	RCV CLK A	int	To DTE	G.703 Contradirectional
5	XMT DAT A	int	To DTE	DS0-DP/G.703
6	RCV DAT A	int	From DTE	DS0-DP/G.703
7	BYTE CLK A	int/ext	To/From DTE	DS0-DP
8	BIT CLK A	int/ext	To/From DTE	DS0-DP
9	N/C	---	---	
10	XMT CLK B	int	To DTE	G.703 Contradirectional
11	RCV CLK B	int	To DTE	G.703 Contradirectional
12	XMT DAT B	int	To DTE	DS0-DP/G.703
13	RCV DAT B	int	From DTE	DS0-DP/G.703
14	BYTE CLK B	int/ext	To/From DTE	DS0-DP
15	BIT CLK B	int/ext	To/From DTE	DS0-DP

C.13 Server Cards

C.13.1 ACS-MCC Server Card (881360)

C.13.1.1 ACS-MCC External Connectors and Pinouts

The ACS-MCC card has an Ethernet interface port and uses a modular jack for a 10Base-T connection. Figure C-46 shows this jack, and Table C-42 lists the pinouts for this jack.

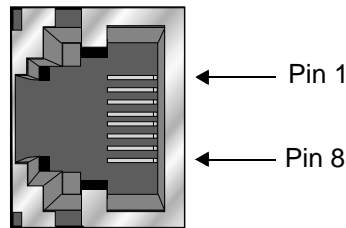

Figure C-46. ACS-MCC Card Ethernet Port Jack

Table C-42. ACS-MCC Card Ethernet Jack Pinouts

Pin	Function	Designation
1	Transmit (+)	X+
2	Transmit (-)	X-
3	Receive (+)	R+
6	Receive (-)	R-
All other pins are open.		

C.13.2 IPR*4 10/100 BT Card (883270)

C.13.2.1 IPR*4 10/100 BT Card External Connectors and Pinouts

The IPR*4 10/100 BT card has four Ethernet interface ports that use a modular jack for a 10/100 Base-T connection. Figure C-47 shows this jack, and Table C-43 lists the pinouts for these jacks.

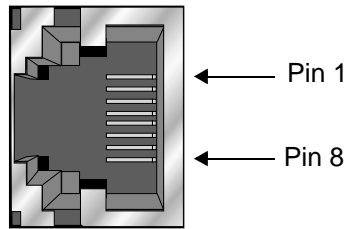

Figure C-47. IPR*4 10/100 BT Card Ethernet Port Jack

Table C-43. IPR*4 10/100 BT Card Ethernet Jack Pinouts

Pin	Function	Designation
1	Transmit (+)	X+
2	Transmit (-)	X-
3	Receive (+)	R+
6	Receive (-)	R-
All other pins are open.		

Appendix D

Node Management Provisioning Examples

D.1 Introduction

This appendix describes various configurations supported on the IMACS. Some of the more enticing features on the IMACS require more in-depth knowledge than is delivered in the individual sections of the manual. This section is our attempt to make understanding of certain IMACS capabilities more clear, by the introduction of example setups of working systems.

D.1.1 Remote Management of IMACS using the E1 SA4 bit

This section covers an example of a point to point configuration of two IMACS. The SA4 bit is a bit reserved in the E1 signal to provide a 4Kbps management channel to a remote IMACS. Due to its' slow speed, this implementation should probably not be used by customers who are foreseeing the need to upgrade the IMACS shelves for future releases. Following is an example using a PC with an Ethernet port connected to an IMACS CPU Ethernet port, and managing a remote IMACS unit using the SA4 bit across an E1.



Figure D-1. Sample Remote Management Need - E1

In Figure D-1, an example is shown of the need for remote management. In this case, the PC and the first IMACS (192.168.1.2) are co-located, and the remote IMACS is accessible over an E1 WAN (192.168.0.2). The following descriptions detail the settings necessary for the craftsman to communicate to the remote IMACS over the E1 using the SA4 bit.

D.1.1.1 Setting up the Local IMACS to Provide Remote Access

Setting up an IMACS to connect to the Ethernet requires the use of a CPU with an ethernet port, an MCC or ACS card, or an IPR card.

Following are screen captures from the various entities required in the setup of the IMACS. This example makes use of the CPU with Ethernet port. If you are unsure on how to get to these screens, please reference the appropriate sections.

CPU IP screen:

```
HOST IP STATE      actv
HOST IP ADDR       192.168.1.2
HOST NETMASK       255.255.255.0
HOST TYPE          gateway
DEFAULT IP PORT    nx64
DEFAULT IP SLOT    n/a
DEFAULT IP UNIT    C1
DEFAULT GATEWAY    0.0.0.0
RPT1 IP ADDR       0.0.0.0
RPT1 COMMUN STR    0.0.0.0
RPT2 IP ADDR       0.0.0.0
RPT2 COMMUN STR    0.0.0.0
RPT3 IP ADDR       0.0.0.0
```

CPU nX64 screen:

	C1	C2	C3	C4
STATE	actv	stdby	stdby	stdby
WAN	lan	none	none	none
TS	n/a	n/a	n/a	n/a
FORMAT	ether	hdlc	hdlc	hdlc
RATE	n/a	56k	56k	56k
MTU	1500	1500	1500	1500

CPU Route screen:

```
IP STATIC ROUTING
IP Net      SubNetMask  SLOT/UNIT  GATEWAY
192.168.0.1 255.255.255.0 w1-1       n/a
```

WAN screen:

	CEPT	STATE	CEPT
STATE	actv	STATE	stdby
MODE	xcon	MODE	xcon
FRAME	crc	FRAME	crc
TS16	cas	TS16	cas
EVEN BIT	norm	EVEN BIT	norm
AIS/ALM	none	AIS/ALM	none
LINE LB	off	LINE LB	off

LOCAL LB	off	LOCAL LB	off
CH LB	off	CH LB	off
LB ADDR	01	LB ADDR	01
LB GEN	off	LB GEN	off
COM/NMS RP	e-sa4	COM/NMS RP	none
EER THRHD	10e-4	EER THRHD	10e-4
RDNT RULES	none	RDNT RULES	none
GROUP	none	GROUP	none

D.1.1.2 Setting up the Remote IMACS to Provide Remote Access

Setting up the remote IMACS to be served by the SA4 bit is referenced in the following examples.

CPU IP screen:

```

HOST IP STATE      actv
HOST IP ADDR       192.168.0.2
HOST NETMASK       255.255.255.255
HOST TYPE          host
DEFAULT IP PORT    wan
DEFAULT IP SLOT    W1
DEFAULT IP UNIT    1
DEFAULT GATEWAY    n/a
RPT1 IP ADDR       0.0.0.0
RPT1 COMMUN STR
RPT2 IP ADDR       0.0.0.0
RPT2 COMMUN STR
RPT3 IP ADDR       0.0.0.0
RPT3 COMMUN STR

```

There are no settings required on the nX64 and rOute screens, only setting of the SA4 bit on the WAN is required.

WAN screen:

	CEPT		CEPT
STATE	actv	STATE	stdby
MODE	xcon	MODE	xcon
FRAME	crc	FRAME	crc
TS16	cas	TS16	cas
EVEN BIT	norm	EVEN BIT	norm
AIS/ALM	none	AIS/ALM	none
LINE LB	off	LINE LB	off
LOCAL LB	off	LOCAL LB	off
CH LB	off	CH LB	off
LB ADDR	01	LB ADDR	01
LB GEN	off	LB GEN	off
COM/NMS RP	e-sa4	COM/NMS RP	none
EER THRHD	10e-4	EER THRHD	10e-4
RDNT RULES	none	RDNT RULES	none
GROUP	none	GROUP	none

D.1.2 Remote Management of an IMACS Using DS0 Daisy-Chaining

The use of the SA4 bit does provide a management channel, but at 4Kbps it has its limitations. For customers desiring a faster connection, use of the full DS0 (64Kbps) is accomplished using WAN ports. This port speed will enable the IMACS to be upgraded remotely.



Figure D-2. Sample Remote Management Need - T1 or E1

The following example allows the remote IMACS shelf to be remotely managed from the local PC.

D.1.2.1 Setting up the Local IMACS for Ethernet Hosting

CPU IP screen:

```
HOST IP STATE      actv
HOST IP ADDR       192.168.1.2
HOST NETMASK       255.255.255.0
HOST TYPE          gateway
DEFAULT IP PORT    nx64
DEFAULT IP SLOT    n/a
DEFAULT IP UNIT    C1
DEFAULT GATEWAY    0.0.0.0
RPT1 IP ADDR       0.0.0.0
RPT1 COMMUN STR
RPT2 IP ADDR       0.0.0.0
RPT2 COMMUN STR
RPT3 IP ADDR       0.0.0.0
RPT3 COMMUN STR
```

CPU nX64 screen:

	C1	C2	C3	C4
STATE	actv	actv	stdby	stdby
WAN	lan	w1-1	none	none
TS	n/a	table	n/a	n/a
FORMAT	ether	hdlc	hdlc	hdlc
RATE	n/a	64k	56k	56k
MTU	1500	1500	1500	1500

CPU rOute screen

```
IP STATIC ROUTING
IP Net          SubNetMask      SLOT/UNIT  GATEWAY
192.168.0.1    255.255.255.0  c1-C2     n/a
```

D.1.2.2 Setting up the Transport IMACS for DS0 Daisy-Chaining

Refer to the Figure D-2 on page D-4. This is the IMACS noted as 192.168.0.2.

CPU IP Screen

```
HOST IP STATE      actv
HOST IP ADDR       192.168.0.2
HOST NETMASK       255.255.255.255
HOST TYPE          gateway
DEFAULT IP PORT    nx64
DEFAULT IP SLOT    n/a
DEFAULT IP UNIT    c1
DEFAULT GATEWAY    n/a
RPT1 IP ADDR       0.0.0.0
RPT1 COMMUN STR
RPT2 IP ADDR       0.0.0.0
RPT2 COMMUN STR
RPT3 IP ADDR       0.0.0.0
RPT3 COMMUN STR
```

CPU nX64 screen

	C1	C2	C3	C4
STATE	actv	stdby	actv	stdby
WAN	W1-1	none	W1-2	none
TS	table	n/a	table	n/a
FORMAT	hdlc	hdlc	hdlc	hdlc
RATE	64k	64k	64k	64k
MTU	1500	1500	1500	240

CPU rOute screen:

```
IP STATIC ROUTING
IP Net          SubNetMask      SLOT/UNIT  GATEWAY
192.168.0.16   255.255.255.240  c1-C3     n/a
```

D.1.2.3 Setting up the Termination IMACS for DS0 Daisy-Chaining

From Figure D-2 on page D-4, this is the last IMACS in the chain, 192.168.0.17.

CPU IP Screen

```
HOST IP STATE      actv
HOST IP ADDR       192.168.0.17
HOST NETMASK       255.255.255.255
HOST TYPE          host
DEFAULT IP PORT    nx64
DEFAULT IP SLOT    n/a
DEFAULT IP UNIT    c1
DEFAULT GATEWAY    n/a
RPT1 IP ADDR      0.0.0.0
RPT1 COMMUN STR   n/a
RPT2 IP ADDR      0.0.0.0
RPT2 COMMUN STR   n/a
RPT3 IP ADDR      0.0.0.0
RPT3 COMMUN STR   n/a
```

CPU nX64 screen

	C1	C2	C3	C4
STATE	actv	stdby	stdby	stdby
WAN	W1-1	none	none	none
TS	table	n/a	n/a	n/a
FORMAT	hdlc	hdlc	hdlc	hdlc
RATE	64k	64k	64k	64k
MTU	1500	1500	1500	240

CPU rOute screen:

No entries, since this is the last node in the chain.

Appendix E

Glossary

Definition of common terms

AAL

ATM Adaption Layer

ABCD bits

The bits that carry signaling information over a T1 or E1 line.

ABR

Available Bit Rate

ACAMI

Alternate Channel AMI, transmitting data on every other DS0 in a DS1 to ensure ones-density.

ACO

Alarm Cutoff

ACS

Advanced Communications Server

ADPCM

Adaptive Differential Pulse Code Modulation

ADPCM Card

A resource card used to compress voice or subrate data on a DS0.

ADSL

Asymmetric Digital Subscriber Line

aggregate

A single bitstream combining many bitstreams of lower rates.

AIS

Alarm Indication Signal

AIS/ALM

Alarm Indication Signal/Alarm

AIM

ATM Inverse Multiplexer

a-law

E1 companding standard used in the conversion between analog and digital signals in PCM

ALIS

Analogue Line Interface Solution systems.

AMI

Alternate Mark Inversion, a line coding format for T1 lines.

ANI

Automatic Number Identification

ANSI

American National Standards Institute

ASCII

American Standard Code for Information Interchange

ASK

Amplitude Shift Keying

ATM

Asynchronous Transfer Mode

AWG

American Wire Gauge (the size of an electrical wire)

B7R

Bit #7 Redundant

B7R card

A network card used to provide Network Management capability for the system.

B8ZS

Bipolar 8-Zero Substitution, a coding scheme that maintains minimum-ones density on a T1 line.

Baud Rate

A measure of transmission speed over an analog phone line

B-channel

In ISDN, a full-duplex, 64 kbps ("bearer") channel that carries user data.

BECN

Backward Explicit Congestion Notification

BER

Bit Error Rate, the number of errored bits divided by the total number of bits.

BERT

Bit Error Rate Tester

BES

A Bursty Errored Second is any second with more than one and fewer than 320 CRC-6 (ESF), BPV (D4/D-frame), or CRC-4 (E1) errors

bit

Contraction of the words "binary" and "digit."

bps

Bits per second (not to be confused with Baud Rate)

BRI

Basic Rate Interface, (2B+D) in ISDN

BRI TE

BRI Terminal Emulation

CAS

Channel-Associated Signaling, a means of conveying voice-circuit signaling over an E1 line.

CAS-CC

Channel Associated Signaling-Common Channel

CAS-BR

Channel Associated Signaling-Bit-robbing mode, used to convey voice-circuit signaling over a T1 line.

CBR

Constant Bit Rate

CCITT

Consultative Committee for International Telegraph and Telephone, now known as the ITU (International Telecommunications Union).

CCR

Current Cell Rate

CCS

Common Channel Signaling

CEP

Connection End Point

CEPT

Conference on European Posts and Telecommunications, a European standards organization.

CES

Circuit Emulation Service

CGA

Carrier Group Alarm, a condition that results from a network failure. Forces all voice circuits off-hook or on-hook until the alarm-causing condition is cleared and the CGA ends.

CLUE

Customer-Located Equipment

clear channel

A DS0 channel without formatting restrictions (i.e., uses the full 64 kbps bandwidth for data transmission).

CO

Central Office

channel bank

A device that places multiple voice and/or data channels onto a digital or analog carrier

CL

Connectionless Service

CPE

Customer Premises Equipment

CODEC

COder/DECoder (a device that encodes and decodes signals)

companding

Non-linear reduction of a signal, usually compressing the larger signal values

CRC

Cyclic Redundancy Check

CRC-4

CRC using four check bits

CRC-6

CRC using six check bits

CSA

Carrier Serving Area

CSC

Common Signaling Channel

CSU

Channel Service Unit, an interface to a T1 line that terminates the local loop.

CTE

Channel Terminating Equipment (Network)

CTS

Clear To Send, a lead on an interface indicating that the DCE is ready to receive data.

D4

A common T1 framing format, consisting of 12 frames. Also known as SF framing.

DACS

Digital Access and Cross-connect System (an electronic digital test access and patching system)

DCC

Data Communication Channel

DCE

Data Communications Equipment

DCS

Digital Cross-connect System

D-channel

Full-duplex, 16 kbps BRI channel or 64 kbps PRI ISDN channel.

DDS

Digital Data Service

d/i

Drop and Insert, one of the modes of operation for the WAN card.

DID

Direct Inward Dialing

DLC

Digital Loop Carrier

DLCI

Data Link Connection Identifier

DM

Degraded Minutes. Number of minutes with ES, UAS or LOS greater than zero (0).

DMA

Direct Memory Access

DPO

Dial-Pulse Originating

DPT

Dial-Pulse Terminating

DRAM

Dynamic Random Access Memory

DS0

Digital Signal - Zero, the standard bandwidth for digitized voice channels. Also referred to as a time slot.

DS0-A

Strategy for mapping a single low-speed data circuit to a single DS0.

DS0-B

Strategy for multiplexing two or more DS0-A low-speed data circuits onto a single DS0 (e.g., 5x9.6kbps, 10x4.8kbps or 20x2.4kbps).

DS0–DP Card

Digital Signal Zero–Dataport Card (one of the data cards for this system).

DS1

Digital Signal, Level 1

DSL

Digital Subscriber Line

DSR

Data Set Ready

DSX

Digital Signal Cross-connect

DTE

Data Terminal Equipment

DTR

Data Terminal Ready

DX

Duplex Signaling

E1

Digital 2.048 Mbps line rate, widely used in countries outside the U.S. and Canada.

EFCI

Explicit Forward Congestion Indicator

ELAN

Emulated Local Area Network

EPROM

Electronic Programmable Read-Only Memory, stores firmware on plug-in modules of the system.

ES

Errored Seconds. The number of seconds for which BRI card has detected a NEBE or FEBE greater than zero (0).

ESF

Extended Superframe (24-frame sequence for a T1 line; consists of two superframes)

ESS

Electronic Switching System

E&M

Earth and Magnetic, or recEive and transMit. The signaling leads on inter-switch voice connections.

E&M Card

An E&M voice card for this system.

ETSI

European Telecommunications Standards Institute

F4

Four-frame multiframe structure used in T1 signals.

FAS

Frame Alignment Signal

FCC

Federal Communications Commission

FDL

Facility Data Link, consists of every other framing bit of an extended T1 superframe. The FDL is used to convey performance data, line test/loopback status, and other parameters for an ESF-framed T1 line. The FDL rate is 4 kHz.

FE1

Fractional E1

FEBE

Far End Block Error, shows transmission errors detected by the far end equipment

FOTS

Fiber Optics Transmission Systems

frame

A delineated assembly of information, consisting of one sequence of 24 encoded channel samples (T1) or 32 channel samples (E1).

FRAD

Frame Relay Assembler/Disassembler, a card used in this system.

FRS

Frame Relay Server, a card used in this system.

FS

Frame Signaling bits (T1 line).

FT

Frame Terminal bits (T1 line)

FT1

Fractional T1

FUNI

Frame User Network Interface

FX

Foreign Exchange, a line that goes from a CO or PBX beyond the PBX or the CO's normal service area.

FXO

Foreign Exchange - Office, performs analog to digital and digital to analog transmission at the CO.

FXO Card

One of the voice cards for this system

FXS

Foreign Exchange - Subscriber or Station, an interface at the end of an FX line connected to a telephone or PBX. Performs digital to analog and analog to digital transmission at the station end.

FXS Card

One of the voice cards for this system

Ground

A physical connection to the earth, chassis, or other reference point

HDB3

High-Density Bipolar Order of 3, three-zero maximum coding for E1 lines. Provides a fourth zero violation for data bytes.

HDLC

High-Level Data Link Control (bit-oriented protocol)

HDSL

High-bit rate Digital Subscriber Line

hlink

A proprietary format for subrate data when using the ADPCM card.

HSU Card

High-Speed Unit Card (one of the data cards for this system).

HMI

Host Management Interface

HOM

HDSL OEM Module

ICMP

Internet Control Message Protocol

IEC

Interexchange Carrier (also called **IXC**)

IMUX

Inverse Multiplexer

IMUX Card

A resource card that gives users access to the ISDN network for bandwidth-on-demand applications.

inverted a-law

A variation of a-law encoding that provides a higher ones density on E1 lines.

IP

Internet Protocol

IPR

Internet Protocol Router

ISP

Internet Service Provider

ITU

International Telecommunications Union (previously known as CCITT [Consultative Committee for International Telegraph and Telephone])

ITU-T

International Telecommunications Union, Technical sector

IXC

Interexchange Carrier (also called **IEC**)

Kbps

Kilobits per second

LAN

Local Area Network

LANE

LAN Emulation

loopback

Path for returning a signal back to the point of origin for circuit testing

LOS

Loss Of Synchronization. Shows the number of seconds for which the BRI card detects LOS.

LSB

Least Significant Bit

LT

Line Termination

LULT

LT Like Unit

LUNT

NT Like Unit

MAC

Media Access Control

MBS

Nortel's Meridian Business Set. An electronic telephone set capable of handling the Meridian Digital Centrex features offered by DMS SuperNode Switch.

Mbps

Megabits per second

MDC

Meridian Digital Centrex

modem

Contraction of the words “modulator” and “demodulator”

MRD

Manual Ringdown

MSP

Maintenance Service Provider

MTS

Memory Time Switch

MTU

Maximum Transfer Unit

mu-law

T1 companding standard used in the conversion between analog and digital signals in PCM systems.

NEBE

Near End Block Error. Shows transmission errors detected by the near end equipment

Network card

A CPU card, Resource card, or WAN card used in this system.

NMS

Network management system, a computer used to control networks from a single location.

NNI

Network Node Interface

NOS

No-Signal Alarm

NRZ

Non-Return-to-Zero signal format

NT

Network Termination

NTU

Network Termination Unit, connects BRI station equipment to the integrated access system. Any standard 2B1Q (U interface) device that supports "nailed-up" (one or two B-channels) connections with no D-channel signaling.

OCU-DP Card

Office Channel Unit - Dataport (one of the data cards for this system).

OOF

Out Of Frame, an indication that the system is searching for the framing bit pattern in the signal received from the network.

OOS

Out of Service, an indication that a system element has failed.

OSI

Open Systems Interconnection

PAM

Pulse Amplitude Modulation

PBX

Private Branch Exchange, a small phone switch inside a company.

PCM

Pulse Code Modulation

PDU

Protocol Data Unit

ping

A program used to test IP-level connectivity from one IP address to another.

PLAR

Private Line Automatic Ringdown

PLR

Pulse Link Repeater

POP

Point of Presence, usually a telephone carrier office.

POTS

Plain Old Telephone Service

PPO

PPhone Foreign Exchange Office card. An interface at the end of the FX line connected to DMS SuperNode Switch.

PPP

Point-to-Point Protocol

PPS

PPhone Foreign Exchange Station Card. An interface at the end of the FX line connected to MBS.

protocol

Procedure or set of rules for communication between two devices.

PSTN

Public Switched Telephone Network.

PTT

Postal, Telephone, and Telegraph authority

PVC

Permanent Virtual Circuit

QAM

Quadrature Amplitude Modulation

RAI

Remote Alarm Indication

Red alarm

A local alarm on a T1 line, indicating that a major failure has occurred at this location.

robbed-bit

A type of analog signaling that occasionally “robs” information bits to convey encoded voice-circuit signaling.

RZ

Return-to-Zero signal format

SAP

Service Access Point

SES

Severely Errored Seconds

SF

Superframe, a T1 framing format consisting of 12 frames. Also known as D4 framing.

SLC[®]

Subscriber Loop Carrier (made by Lucent Technologies, sometimes called one example of a Digital Loop Carrier (DLC) System.

SLIP

Serial Line Internet Protocol

SMDS

Switched Multi megabit Data Service

SNMP

Simple Network Management Protocol

SONET

Synchronous Optical Network

SRU Card

Subrate Unit Card (one of the data cards for this system).

system

Often used as a synonym for the integrated access system.

TA

Terminal Adapter

TE

Terminal Equipment

T1

The North American DS1 transmission rate, 1.544 Mbps.

TAD

Test Access Digroup

TCP/IP

Transmission Control Protocol/Internet Protocol

TDM

Time-Division Multiplexing

TELNET

An application protocol offering virtual terminal service in the Internet suite of protocols.

time slot map

Specification of the connections between all incoming and outgoing lines connected to the system. A cross-connect map allows users to split the bandwidth of T1 and E1 lines into amounts more suitable for normal voice and data communications.

TS

Time Slot

TSA

Time Slot Assigner

UART

Universal Asynchronous Receiver/Transmitter

UAS

Unavailable Seconds. Incremented by 10 when LOS has remained for more than 10 consecutive seconds and incremented by 1 every second until LOS is removed.

UDP

User Datagram Protocol

UI

Unit Interval

UNI

User Network Interface

User card

A Voice card, Data card, or Alarm card.

VBR

Variable Bit Rate

VC

Virtual Channel

VCL

Virtual Channel Link

VP

Virtual Path

VPC

Virtual Path Connection

WAN

Wide Area Network

WAN Card

Wide Area Network Card (one of the cards for this system).

wideband

A bandwidth equal to many individual channels

X.50

CCITT (ITU) standard data transmission protocol.

yellow alarm

Remote alarm on a T1 line. A major failure has occurred at a remote location.

ZCS

Zero Code Suppression

INDEX

A

ADPCM

- compression rates 19-2, 19-6
- engines 19-1
- time slots 19-5

ADPCM card

- compression engines 19-1
- compression rates 19-2
- configuration 19-3
- description 19-1
- error messages 19-7, 22-16
- option settings and defaults 19-4
- signaling modes supported 19-2
- time slot assignments 19-2
- troubleshooting 19-8

ADPCM card redundancy

- viewing current ADPCM status 5-125

ADPCM compression rates 11-10, 12-12, 13-9

ADPCM configuration

- ADPCM TS (outgoing time slot) 19-5
- ADPCM WAN (outgoing link) 19-5
- CODING (incoming PCM companding type) 19-6
- RATE (ADPCM compression rate) 19-6
- SIG MODE (incoming signaling type) 19-6
- STATE (activating a port) 19-4
- TC CGA (incoming trunk conditioning) 19-7
- TS (incoming time slot) 19-5
- TYPE (incoming voice/signaling type) 19-6
- USER (user card and port) 19-5
- WAN (incoming link) 19-5

Alarm card

- configuration, alarm sensor filter 10-3

Alarm printing setup

- ELEMENT 1 - 6 (alarm elements) 7-19
- PRT ALARMS (remote printing device) 7-17
- PRT ATTEMPTS (number of print attempts) 7-18
- PRT MAJ&CRIT (major/critical alarms) 7-18
- PRT MIN&INFO (minor/info alarms) 7-18
- PRT PHONE# (dial-out phone number) 7-18
- PRT RETRY (number of redial attempts) 7-18
- purpose 7-15
- typical alarm printout 7-19

Assigning a time slot

- incoming traffic 19-5
- outgoing traffic 19-5

INDEX

- Assigning a user card and port 19-5
- Assigning a WAN link
 - incoming traffic 19-5
 - outgoing traffic 19-5

B

- Broadcasting
 - adding a connection 5-103
 - deleting a connection 5-100, 5-103
 - updating a connection 5-103
 - viewing connections 5-103

C

- CGA trunk conditioning 19-7
- Changing passwords 7-10
- Chassis configuration for U.S. or Europe 3-11
- Checking the time slot map 5-113
- Clearing the user data registers 9-39
- Compression rates 19-2, 19-6
- Configuring an ADPCM card 19-3
- Configuring the CPU card
 - system setup 7-13
 - TCP/IP network management 7-20
 - when to do 7-6
- Configuring the E&M card
 - ADPCM (assign an ADPCM card) 11-10
 - CODING (PCM companding) 11-8
 - description 11-5
 - LB (loopbacks) 11-9
 - MODE (E&M signaling) 11-7
 - PATTRN (send test signal) 11-9
 - RATE (compression rate, ADPCM) 11-10
 - RX TLP (receive TLP) 11-8
 - SIG CONV (convert signaling bits) 11-10
 - STATE (activating a port) 11-7
 - TC CGA (trunk conditioning) 11-8
 - TS (assign time slot) 11-7
 - TX TLP (transmit TLP) 11-8
 - WAN/SRV (assign WAN or server port) 11-7
- Configuring the FXO card
 - ADPCM (assign an ADPCM card) 13-10
 - CODING (PCM companding) 13-7
 - description 13-3
 - HYBRID (set line build-out) 13-9
 - LB (loopback on/off) 13-8
 - MODE (choose signaling mode) 13-6
 - PATTRN (send test signal) 13-8

- RATE (compression rate, ADPCM) 13-9
- RX TLP (receive TLP) 13-7
- SIG CONV (signaling conversion) 13-9
- SIGNAL (choose signaling type) 13-6
- STATE (activating a port) 13-5
- TC CGA (trunk conditioning) 13-7
- TS (assign time slot) 13-6
- TX TLP (transmit TLP) 13-7
- WAN/SRV (assign WAN or server port) 13-5
- WINK (duration of wink) 13-9
- WK DLY (wink delay time) 13-9
- Configuring the FXS card
 - ADPCM (assign an ADPCM card) 12-12
 - CODING (PCM companding) 12-10
 - description 12-3
 - HYBRID (set line build-out) 12-11
 - LB (loopback on/off) 12-10
 - MODE (choose signaling mode) 12-6
 - PATTRN (send test signal) 12-11
 - RATE (compression rate, ADPCM) 12-12
 - RINGBK (send ringback tone) 12-11
 - RX TLP (receive TLP) 12-9
 - SIG CONV (convert signaling bits) 12-11
 - STATE (activating a port) 12-5
 - TC CGA (trunk conditioning) 12-10
 - TS (assign time slot) 12-5
 - TX TLP (transmit TLP) 12-9
 - TYPE (choose signaling type toward CPE) 12-6
 - WAN/SRV (assign WAN or server port) 12-5
- Configuring the Interface card
 - user interface ports 8-22
- Configuring the OCU-DP card
 - description 17-3
- Configuring WAN cards
 - T1 CSU and DSX operation 9-20
- Connectors and pinouts C-30
 - ALR 4+4 (S 60) card C-25
 - E&M 4W*8 (S 60) card C-26, C-27
 - FXS 2W*8-6 (S 60) card C-29
 - OCU-DP 5 (S 60) card C-57
- CPU card
 - changing passwords 7-10
 - configuration 7-6
 - installation 7-3
 - other configuration settings 7-13
 - TCP/IP management 7-20
 - troubleshooting 7-60
- Cross-connecting time slots
 - deleting a connection 5-91
 - signaling conversion 5-86

INDEX

CSU module
description 9-18
installation 9-18

D

Description
alarm printing 7-15
configuration 11-5, 12-3, 13-3
CSU module 9-18
DS0-DP card 18-1
E&M 4W*8 (S 60) card C-27
E&M 4W*8 ER (S 60) card 11-4
FXO card 13-1, C-30
FXS 2W*8-6 (S 60) card 12-1, C-29
IP packet routing 7-42
TCP/IP network management 7-20
testing 11-11, 12-13, 13-11
Description of ADPCM card 19-1
DS0-DP card
description 18-1
DSX/CEPT module
description 9-13
installation 9-14
jumper settings 9-14

E

E&M card
configuration 11-5
connectors and pinouts C-26, C-27
description 11-4
error messages 11-18
installation 11-4, 20-2, C-27
signaling modes supported 11-7
switch settings 11-4
testing 11-11
troubleshooting 11-18
E&M signaling types 11-3
Error messages 11-18, 13-16, 19-7, 22-16

F

FDL parameters
display, typical 7-30
frames aborted upon transmission 7-33
frames to transmit from above 7-33
FXO card
configuration 13-3

- connectors and pinouts C-30
- description 13-1, C-30
- error messages 13-16
- installation 13-2
- jumper settings 13-2
- testing 13-11
- troubleshooting 13-16

FXS card

- configuration 12-3
- connectors and pinouts C-29
- description 12-1, C-29
- installation 12-3
- testing 12-13
- troubleshooting 12-18

I

ICMP parameters

- destination unreachable 7-35
- display, typical 7-33
- echo replies received 7-35
- echo replies sent 7-35
- echo requests received 7-35
- echo requests sent 7-35
- messages sent 7-35

Incoming circuit configuration

- CGA trunk conditioning 19-7
- compression rate 19-6
- PCM coding 19-6
- signaling mode 19-6
- user card and port 19-5
- voice/signaling type 19-6
- WAN link 19-5
- WAN time slot 19-5

Installation

- CSU modules 9-18
- DSX/CEPT modules 9-14
- redundant card chassis slot 9-18
- WAN cards 9-18

Installing the ADPCM card 19-2

Installing the CPU card 7-3

Installing the E&M card

- E&M 4W*8 (S 60) card 11-4, 20-2, C-27
- E&M 4W*8 ER (S 60) card 11-4

Installing the FXO card 13-2

Installing the FXS card

- FXS 2W*8-6 (S 60) card 12-3

Installing the OCU-DP card 17-2

IP packet routing setup

INDEX

- description 7-42
- example 7-43
- REM NETM 7-45
- REM START and REM END 7-45

IP parameters

- datagrams delivered above 7-34
- datagrams discarded 7-34
- datagrams from above 7-34
- datagrams received from network 7-34
- datagrams sent to network 7-34
- default TTL 7-34
- display, typical 7-33
- TX discarded, mailbox overflow 7-34
- TX discarded, other causes 7-35
- TX wait for RAM 7-34

J

- Jumper settings 13-2
 - DSX/CEPT revision F module 9-16

L

- Loopbacks 11-9, 12-10, 13-8

M

- Main screen 7-6, 11-5, 12-3, 13-3, 19-3

N

Network statistics

- FDL 7-32
- ICMP 7-35
- IP 7-33
- SLIP 7-31
- SNMP 7-41
- TCP 7-36
- TELNET 7-40
- UDP 7-39

NVRAM

- configuration data stored in 5-26
- system zipping effects on 5-28

O

OCU-DP card

- configuration 17-3
- connectors and pinouts C-57

- installation 17-2
- Option settings and defaults 19-4
 - configuration 11-6, 12-4, 13-4, 17-4
 - C-port and numbered port configuration 22-9
 - IP packet routing 7-45, 7-47
 - summary, alarm printing 7-17
 - summary, TCP/IP management 7-22, 7-50
 - testing 11-12, 11-17, 12-14, 13-12
- Options and default settings
 - summary, WAN testing 9-45
- Outgoing circuit configuration
 - WAN link 19-5
 - WAN time slot 19-5

P

- Passwords
 - changing 7-10
- PCM coding selection 19-6
- PCM companding conversion 5-85
- Performance data
 - clearing user registers 9-39
 - network registers 9-39
- Power converters
 - 48V specifications 2-11
- Power supply redundancy
 - description 5-117
 - viewing power supply status 5-118
- Pre-installation requirements
 - installation sequence 2-2
- Printing alarms 7-15

R

- Redundant Power Supply Safety Information A-22

S

- Screens
 - IP and ICMP statistics 7-33
 - IP routing 7-44
 - main 7-6, 11-5, 12-3, 13-3
 - print alarm, typical 7-16
 - SLIP and FDL statistics 7-30
 - TCP statistics 7-36
 - TCP/IP 7-21
 - test 11-11, 12-13, 13-11
 - UDP, TELNET, and SNMP parameters 7-39
- Signaling conversion 5-86

INDEX

Signaling mode selection 19-6

SLIP parameters

buffer overflow, incoming 7-32

bytes received from network 7-31

display, typical 7-30

MTU size (maximum outgoing packet size) 7-31

packets discarded from network 7-31

packets dropped, insufficient memory 7-32

packets received from network 7-31

packets sent to network 7-32

SNMP parameters

display, typical 7-39

PDU sent 7-41

traps sent 7-41

Switch settings

E&M 4W*8 ER (S 60) card 11-4

System setup

ACO (alarm cutoff status) 7-14

ALRM SEQ (alarm sequence numbering) 7-14

NODE ID (system name) 7-13

SYS CONT (system contact person) 7-13

SYS LOC (system location) 7-14

SYS PH# (system access phone number) 7-14

T

TCP parameters

acknowledgments received 7-37

bytes delivered above 7-37

bytes from above 7-37

connections aborted 7-38

connections closed 7-38

connections opened 7-38

display, typical 7-36

packets discarded, checksum error 7-36

packets discarded, incorrect window data 7-37

packets received 7-36

packets retransmitted 7-37

packets sent 7-37

packets sent, acknowledgment 7-37

packets sent, reset (total TCP packets) 7-37

packets TX aborted - RAM 7-38

RTT decreased 7-38

RTT increased 7-38

TCP/IP network management

default IP port 7-24

default IP WAN/server card slot 7-25

default IP wan/server port 7-25

purpose 7-20

- RPT1 COMMUN STR 7-26
- RPT2 COMMUN STR 7-26
- RPT2 IP ADDR 7-26
- RPT3 COMMUN STR 7-26
- RPT3 IP ADDR 7-26
- TELNET parameters
 - bytes delivered above 7-40
 - bytes received 7-40
 - bytes received above 7-40
 - bytes received as commands 7-40
 - bytes replied as commands 7-40
 - bytes sent 7-40
 - display, typical 7-39
 - sessions closed 7-41
 - sessions opened 7-40
 - TX wait for buffer 7-41
- Test screen 11-11, 12-13, 13-11
- Testing the E&M card
 - E-LEAD (send E-lead state to CPE) 11-13
 - loopbacks 11-9
 - RX ABCD (send signaling bits to CPE) 11-13
 - SIG MON (enable sig transition alarm) 11-12
 - TEST (view port test status) 11-12
 - TO NTWK (send test signal to network) 11-13
 - TO USER (send test signal to CPE) 11-13
 - TX ABCD (send signaling bits to network) 11-13
- Testing the FXO card
 - description 13-11
 - loopbacks 13-8
 - RX ABCD (send signaling bits to CPE) 13-13
 - SIG MON (enable sig transition alarm) 13-12
 - TO NTWK (send test signal to network) 13-13
 - TO USER (send test signal to CPE) 13-13
 - T-R CNTL (set tip-ring lead states) 13-13
 - TX ABCD (send signaling bits to network) 13-12
- Testing the FXS card
 - description 12-13
 - loopbacks 12-10
 - RX ABCD (send signaling bits to CPE) 12-15
 - SIG MON (enable sig transition alarm) 12-14
 - TO NTWK (send test signal to network) 12-15
 - TO USER (send test signal to CPE) 12-15
 - T-R CNTL (set tip-ring lead states) 12-15
 - TX ABCD (send signaling bits to network) 12-14
- Time slot assignments 19-2
- Time slots
 - checking the map 5-113
- Troubleshooting 7-60, 11-18, 12-18, 13-16, 19-8

INDEX

U

UDP parameters

- display, typical 7-39
- packets from above 7-39
- packets sent 7-39

V

Viewing performance data

- clearing data registers 9-39
- user registers 9-39

Viewing port information

- CPE activity on tip and ring 12-16, 13-14
 - current status 11-14, 12-17, 13-15
 - E&M signaling type 11-15
 - E-lead status 11-14
 - M-lead status 11-14
 - port test status 11-12
 - received signaling bits 11-14, 12-16, 13-14
 - signaling mode 11-14, 12-16, 13-14
 - signaling type 12-16, 13-15
 - test status 12-14, 13-12
 - tip-ring lead status 12-16, 13-14
 - transmitted signaling bits 11-14, 12-15, 13-13
- Viewing the power supply redundancy status 5-118
- Voice/signaling type setting 19-6

W

WAN card

- description, dual card 9-1, 9-11
- description, WAN-R card 9-12, 9-13
- installation 9-18
- T1 configuration 9-20

Z

- Zipping the system 5-28